

# BT151

SCR

## SCRS

### DESCRIPTION

Passivated thyristors in a plastic envelope, intended for use in applications requiring high bidirectional blocking voltage capability and high thermal cycling performance. Typical applications include motor control, industrial and domestic lighting, heating and static switching.

### SYMBOL

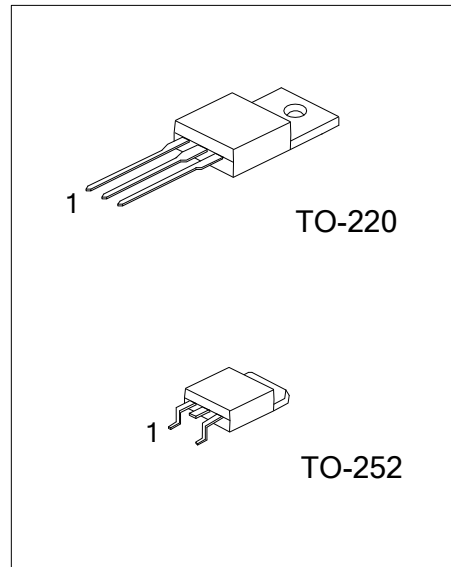
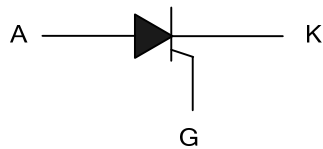

### ORDERING INFORMATION

Order Number		Package	Pin Assignment			Packing
Lead Free	Halogen Free		1	2	3	
BT151L-5-TA3-T	BT151G-5-TA3-T	TO-220	K	A	G	Tube
BT151L-5-TN3-R	BT151G-5-TN3-R	TO-252	K	A	G	Tape Reel
BT151L-6-TA3-T	BT151G-6-TA3-T	TO-220	K	A	G	Tube
BT151L-6-TN3-R	BT151G-6-TN3-R	TO-252	K	A	G	Tape Reel
BT151L-8-TA3-T	BT151G-8-TA3-T	TO-220	K	A	G	Tube
BT151L-8-TN3-R	BT151G-8-TN3-R	TO-252	K	A	G	Tape Reel

Note: Pin assignment: K: CATHODE    A: ANODE    G: GATE

<p>BT151L-5-TA3-R</p> <p>(1) Packing Type</p> <p>(2) Package Type</p> <p>(3) Lead Free</p>	<p>(1) R: Tape Reel, T: Tube</p> <p>(2) TA3: TO-220, TN3: TO-252</p> <p>(3) G: Halogen Free, L: Lead Free</p>
--	---

## ■ ABSOLUTE MAXIMUM RATING

PARAMETER		SYMBOL	RATINGS	UNIT
Repetitive Peak Off-State Voltages	BT151-5	$V_{DRM}, V_{RRM}$	500 (Note 1)	V
	BT151-6		650 (Note 1)	
	BT151-8		800	
Average On-State Current (half sine wave; $T_{mb} \leq 109^\circ\text{C}$ )		$I_{T(AV)}$	7.5	A
RMS on-State Current (all conduction angles)		$I_{T(RMS)}$	12	A
Non-Repetitive Peak On-State Current (half sine wave; $T_J = 25^\circ\text{C}$ prior to surge)	$t = 10\text{ ms}$	$I_{TSM}$	100	A
	$t = 8.3\text{ ms}$		110	
$I^2t$ for Fusing ( $t = 10\text{ ms}$ )		$I^2t$	50	$\text{A}^2\text{s}$
Repetitive Rate of Rise of On-State Current After Triggering ( $I_{TM} = 20\text{ A}$ ; $I_G = 50\text{ mA}$ ; $dI_G/dt = 50\text{ mA}/\mu\text{s}$ )		$dI_T/dt$	50	$\text{A}/\mu\text{s}$
Peak Gate Current		$I_{GM}$	2	A
Peak Gate Voltage		$V_{GM}$	5	V
Peak Reverse Gate Voltage		$V_{RGM}$	5	V
Peak Gate Power		$P_{GM}$	5	W
Average Gate Power (Over any 20 ms period)		$P_{G(AV)}$	0.5	W
Storage Temperature		$T_{stg}$	-40 ~ 150	$^\circ\text{C}$
Operating Junction Temperature		$T_J$	125	$^\circ\text{C}$

Note: 1. Although not recommended, off-state voltages up to 800V may be applied without damage, but the thyristor may switch to the on-state. The rate of rise of current should not exceed  $15\text{ A}/\mu\text{s}$ .

2. Absolute maximum ratings are those values beyond which the device could be permanently damaged. Absolute maximum ratings are stress ratings only and functional device operation is not implied.

## ■ THERMAL DATA

PARAMETER	SYMBOL	RATINGS	UNIT
Junction to Mounting Base	$\theta_{JMb}$	1.3	K/W
Junction to Ambient	$\theta_{JA}$	60	K/W

## ■ STATIC CHARACTERISTICS ( $T_J=25^\circ\text{C}$ , unless otherwise stated)

PARAMETER	SYMBOL	CONDITIONS	MIN	TYP	MAX	UNIT
Gate Trigger Current	$I_{GT}$	$V_D = 12\text{ V}$ , $I_T = 0.1\text{ A}$		2	15	mA
Latching Current	$I_L$	$V_D = 12\text{ V}$ , $I_{GT} = 0.1\text{ A}$		10	40	mA
Holding Current	$I_H$	$V_D = 12\text{ V}$ , $I_{GT} = 0.1\text{ A}$		7	20	mA
On-State Voltage	$V_T$	$I_T = 23\text{ A}$		1.4	1.75	V
Gate Trigger Voltage	$V_{GT}$	$V_D = 12\text{ V}$ , $I_T = 0.1\text{ A}$		0.6	1.5	V
		$V_D = V_{DRM(max)}$ , $I_T = 0.1\text{ A}$ , $T_J = 125^\circ\text{C}$	0.25	0.4		
Off-State Leakage Current	$I_D, I_R$	$V_D = V_{DRM(max)}$ , $V_R = V_{RRM(max)}$ , $T_J = 125^\circ\text{C}$		0.1	0.5	mA

## ■ DYNAMIC CHARACTERISTICS ( $T_J=25^\circ\text{C}$ , unless otherwise stated)

PARAMETER	SYMBOL	CONDITIONS	MIN	TYP	MAX	UNIT
Critical Rate of Rise of Off-State Voltage	$dV_D/dt$	$V_{DM} = 67\% V_{DRM(max)}$ , $T_J = 125^\circ\text{C}$ , exponential waveform;	Gate open circuit	50	130	V/ $\mu\text{s}$
			$R_{GK} = 100\Omega$	200	1000	
Gate Controlled Turn-on Time	$t_{GT}$	$I_{TM} = 40\text{ A}$ , $V_D = V_{DRM(max)}$ , $I_G = 0.1\text{ A}$ , $dI_G/dt = 5\text{ A}/\mu\text{s}$		2		$\mu\text{s}$
Circuit Commutated Turn-off time	$t_Q$	$V_D = 67\% V_{DRM(max)}$ , $T_J = 125^\circ\text{C}$ ; $I_{TM} = 20\text{ A}$ , $V_R = 25\text{ V}$ , $dI_{TM}/dt = 30\text{ A}/\mu\text{s}$ , $dV_D/dt = 50\text{ V}/\mu\text{s}$ , $R_{GK} = 100\Omega$		70		$\mu\text{s}$

■ TYPICAL CHARACTERISTICS

Fig 1. Maximum On-State Dissipation,  $P_{tot}$ , Versus Average On-State Current,  $I_{T(AV)}$ , Where  $a = \text{form factor} = I_{T(RMS)} / I_{T(AV)}$

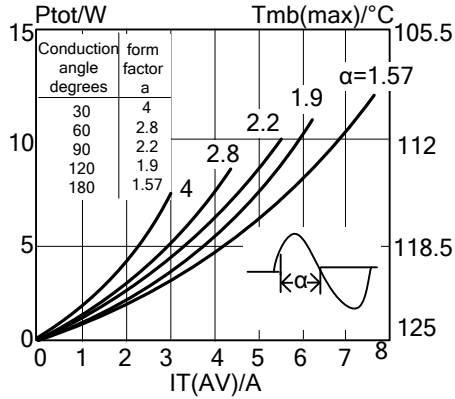

Fig 2. Maximum Permissible Non-Repetitive Peak On-State Current  $I_{TSM}$ , Versus Pulse Width  $t_p$  for Sinusoidal Currents,  $t_p \leq 10ms$

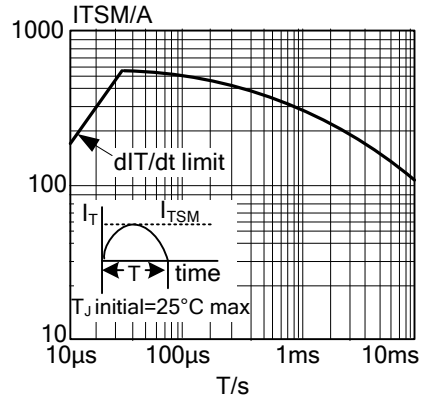

Fig 3. Maximum Permissible Rms Current  $I_{T(RMS)}$ , Versus Mounting Base Temperature  $T_{mb}$

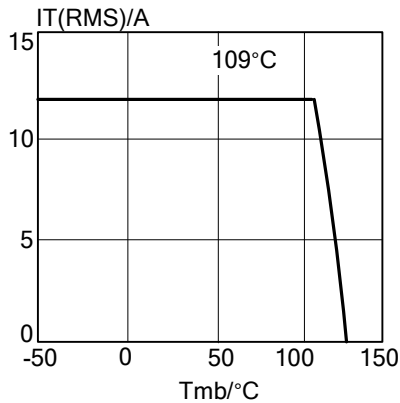

Fig 4. Maximum Permissible Non-Repetitive Peak On-State Current  $I_{TSM}$ , Versus Number Of Cycles, For Sinusoidal Currents,  $f=50\text{HZ}$

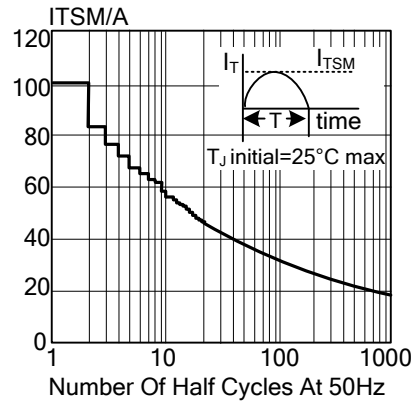

Fig 5. Maximum Permissible Repetitive Rms On-State Current  $I_{T(RMS)}$ , Versus Surge Duration, For Sinusoidal Currents,  $f=50\text{HZ}$ ;  $T_{mb} \leq 109^\circ\text{C}$

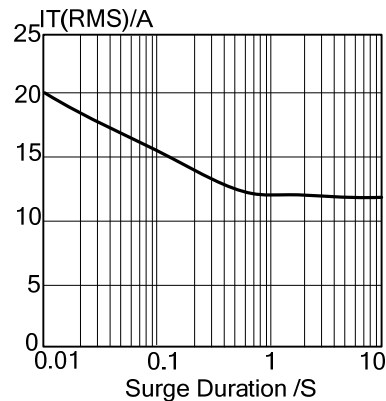
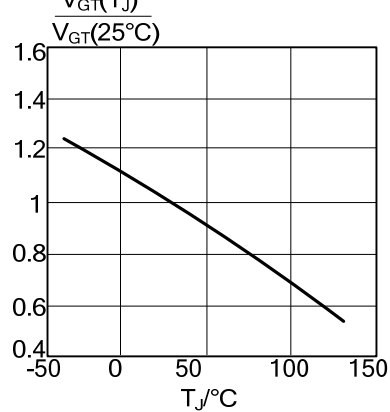

Fig 6. Normalised Gate Trigger Voltage  $V_{GT}(T_J) / V_{GT}(25^\circ\text{C})$ , Versus Junction Temperature  $T_J$



■ TYPICAL CHARACTERISTICS (Cont.)

Fig 7. Normalised Gate Trigger Current  $I_{GT}(T_J)/I_{GT}(25^\circ\text{C})$ , Versus Junction Temperature  $T_J$

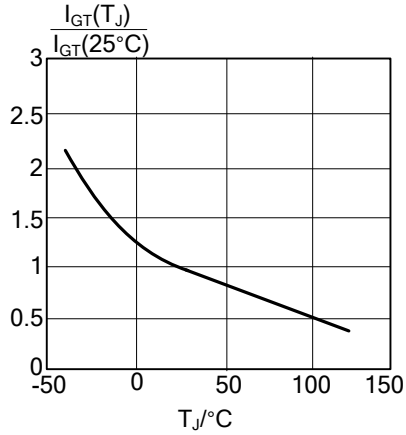

Fig 8. Normalised Latching Current  $I_L(T_J)/I_L(25^\circ\text{C})$ , Versus Junction Temperature  $T_J$

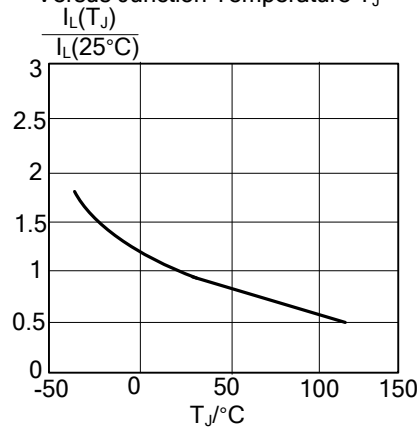

Fig 9. Normalised Holding Current  $I_H(T_J)/I_H(25^\circ\text{C})$ , Versus Junction Temperature  $T_J$

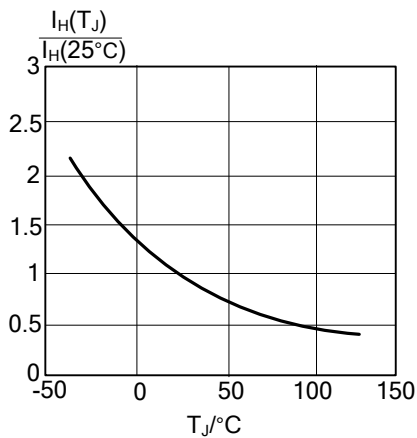

Fig 10. Typical and Maximum On-State Characteristic

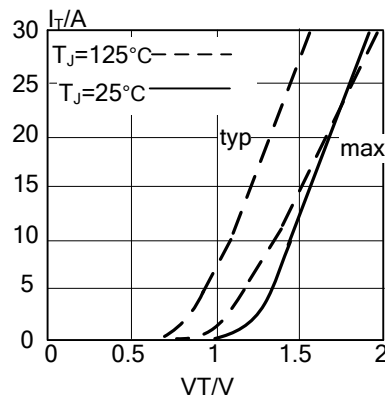

Fig 11. Transient Thermal Impedance  $Z_{thj-mb}$ , Versus Pulse Width  $t_p$

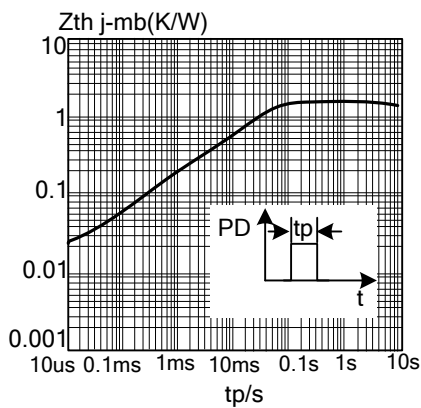
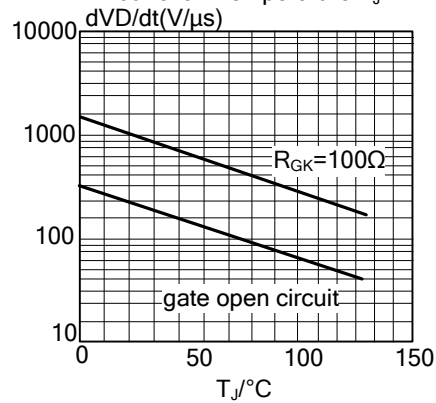

Fig 12. Typical, Critical Rate Of Rise Of Off-State Voltage,  $dV_D/dt$  Versus Junction Temperature  $T_J$



UTC assumes no responsibility for equipment failures that result from using products at values that exceed, even momentarily, rated values (such as maximum ratings, operating condition ranges, or other parameters) listed in products specifications of any and all UTC products described or contained herein. UTC products are not designed for use in life support appliances, devices or systems where malfunction of these products can be reasonably expected to result in personal injury. Reproduction in whole or in part is prohibited without the prior written consent of the copyright owner. The information presented in this document does not form part of any quotation or contract, is believed to be accurate and reliable and may be changed without notice.