



# U74HCT3G06

CMOS IC

## INVERTER WITH OPEN-DRAIN OUTPUTS

### DESCRIPTION

The **U74HCT3G06** provides three inverters with open-drain outputs, it is compatible with TTL.

### FEATURES

- \* Low power dissipation
- \* High speed
- \* High noise immunity

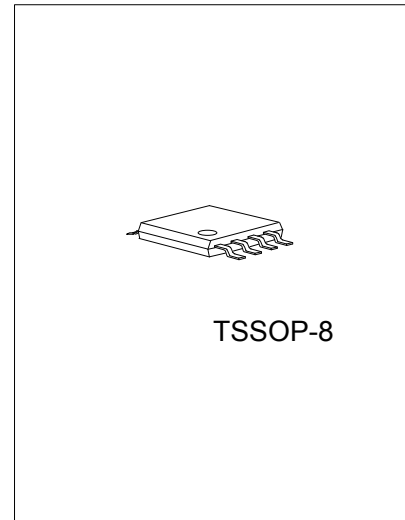

### ORDERING INFORMATION

Ordering Number		Package	Packing
Lead Free	Halogen Free		
U74HCT3G06L-P08-R	U74HCT3G06G-P08-R	TSSOP-8	Tape Reel
U74HCT3G06L-P08-T	U74HCT3G06G-P08-T	TSSOP-8	Tube

<p>U74HCT3G06L-P08-R</p> <p>(1)Packing Type (2)Package Type (3)Lead Free</p>	<p>(1) R: Tape Reel, T: Tube (2) P08: TSSOP-8 (3) G: Halogen Free, L: Lead Free</p>
--------------------------------------------------------------------------------------	---------------------------------------------------------------------------------------------

■ PIN CONFIGURATION

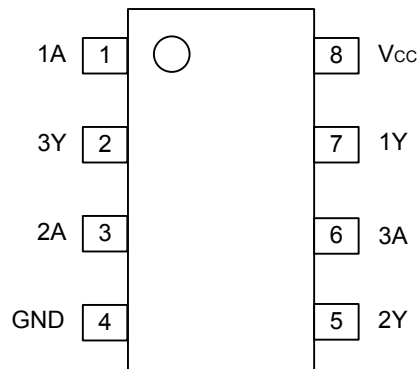

■ FUNCTION TABLE (each gate)

INPUT(A)	OUTPUT(Y)
L	Z
H	L

■ LOGIC DIAGRAM (positive logic)

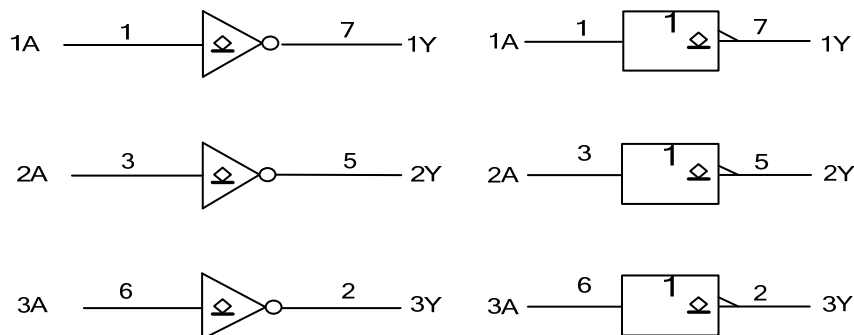

## ■ ABSOLUTE MAXIMUM RATINGS (unless otherwise specified)

PARAMETER	SYMBOL	RATINGS	UNIT
Supply Voltage	$V_{CC}$	-0.5~7	V
Output Voltage	$V_{OUT}$	-0.5~ $V_{CC}+0.5$ (active mode) -0.5~7.0(high-impedance mode)	V
$V_{CC}$ or GND Current	$I_{CC}$	50	mA
Input Clamp Current	$I_{IK}$	±20	mA
Output Clamp Current	$I_{OK}$	-20	mA
Output Current	$I_{OUT}$	25	mA
Power Dissipation	$P_D$	300	mW
Storage Temperature	$T_{STG}$	-65 ~ +150	°C

Note: Absolute maximum ratings are those values beyond which the device could be permanently damaged.

Absolute maximum ratings are stress ratings only and functional device operation is not implied.

## ■ RECOMMENDED OPERATING CONDITIONS

PARAMETER	SYMBOL	CONDITIONS	MIN	TYP	MAX	UNIT
Supply Voltage	$V_{CC}$		4.5	5.0	5.5	V
Input Voltage	$V_{IN}$		0		5.5	V
Output Voltage	$V_{OUT}$		0		$V_{CC}$	V
Input Rise and Fall Times	$t_R, t_F$	$V_{CC}=4.5V$		6.0	500	ns
Operating Temperature	$T_A$		-40	+25	+125	°C

## ■ STATIC CHARACTERISTICS ( $T_A=25^\circ C$ )

PARAMETER	SYMBOL	TEST CONDITIONS	MIN	TYP	MAX	UNIT
High-Level Input Voltage	$V_{IH}$	$V_{CC}=4.5V\sim 5.5V$	2.0	1.6		V
Low-Level Input Voltage	$V_{IL}$	$V_{CC}=4.5V\sim 5.5V$		1.2	0.8	V
Low-Level Output Voltage	$V_{OL}$	$V_{CC}=4.5V, I_{OL}=20\mu A$		0	0.1	V
		$V_{CC}=4.5V, I_{OL}=4.0mA$		0.15	0.33	V
Input Leakage Current	$I_{I(LEAK)}$	$V_{CC}=5.5V, V_{IN}=V_{CC}$ or GND			±1.0	μA
Output Leakage Current	$I_{O(LEAK)}$	$V_{CC}=5.5V, V_{IN}=V_{IH},$ $V_{OUT}=V_{CC}$ or GND			±5.0	μA
Quiescent Supply Current	$I_Q$	$V_{CC}=5.5V, V_{IN}=V_{CC}$ or GND, $I_{OUT}=0$			10	μA
Additional Quiescent Supply Current	$\Delta I_Q$	$V_{CC}=4.5V$ to $5.5V, V_{IN}=V_{CC}-2.1V,$ $I_{OUT}=0$			375	μA
Input Capacitance	$C_{IN}$			1.5		pF

## ■ DYNAMIC CHARACTERISTICS ( $T_A=25^\circ C, t_R, t_F\leq 6.0ns$ )

PARAMETER	SYMBOL	TEST CONDITIONS	MIN	TYP	MAX	UNIT
Propagation Delay From nA to nY	$t_{PZL}$	$V_{CC}=4.5V, C_L=50 pF$		9	24	ns
	$t_{PLZ}$	$V_{CC}=4.5V, C_L=50 pF$		12	27	
Output Transition Time	$t_{THL}$	$V_{CC}=4.5V, C_L=50 pF$		6	19	ns

## ■ OPERATING CHARACTERISTICS

PARAMETER	SYMBOL	TEST CONDITIONS	MIN	TYP	MAX	UNIT
Power Dissipation Capacitance	$C_{PD}$			4		pF

■ TEST CIRCUIT AND WAVEFORMS

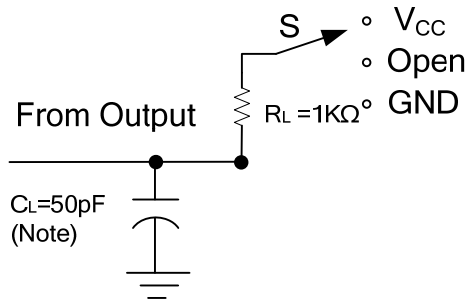

TEST	S
$t_{PLH}/t_{PHL}$	$V_{CC}$
$t_{PLZ}/t_{PZL}$	$V_{CC}$

Note :  $C_L$  includes probe and jig capacitance.

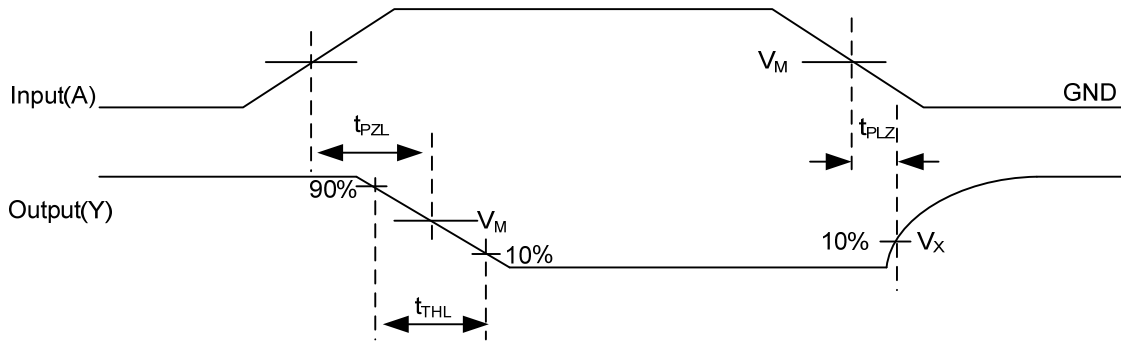

$V_M=1.3V$ , Input=GND to 3.0V,  $V_X=10\%*V_{CC}$

UTC assumes no responsibility for equipment failures that result from using products at values that exceed, even momentarily, rated values (such as maximum ratings, operating condition ranges, or other parameters) listed in products specifications of any and all UTC products described or contained herein. UTC products are not designed for use in life support appliances, devices or systems where malfunction of these products can be reasonably expected to result in personal injury. Reproduction in whole or in part is prohibited without the prior written consent of the copyright owner. The information presented in this document does not form part of any quotation or contract, is believed to be accurate and reliable and may be changed without notice.