



U74HCT3G07

CMOS IC

BUFFER WITH OPEN-DRAIN OUTPUTS

DESCRIPTION

The **U74HCT3G07** provides three buffers with open-drain outputs, it is compatible with TTL.

FEATURES

- * Low power dissipation
- * High speed
- * High noise immunity

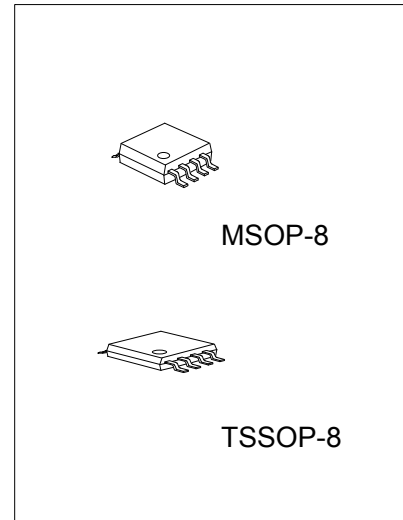

*Pb-free plating product number:
U74HCT3G07L

ORDERING INFORMATION

Ordering Number		Package	Packing
Normal	Lead Free Plating		
U74HCT3G07-P08-R	U74HCT3G07L-P08-R	TSSOP-8	Tape Reel
U74HCT3G07-P08-T	U74HCT3G07L-P08-T	TSSOP-8	Tube
U74HCT3G07-SM1-R	U74HCT3G07L-SM1-R	MSOP-8	Tape Reel
U74HCT3G07-SM1-T	U74HCT3G07L-SM1-T	MSOP-8	Tube

<p>U74HCT3G07L-P08-R</p> <p>(1)Packing Type (2)Package Type (3)Lead Plating</p>	<p>(1) R: Tape Reel, T: Tube (2) P08: TSSOP-8, SM1: MSOP-8 (3) L: Lead Free Plating, Blank: Pb/Sn</p>
---	---

■ PIN CONFIGURATION

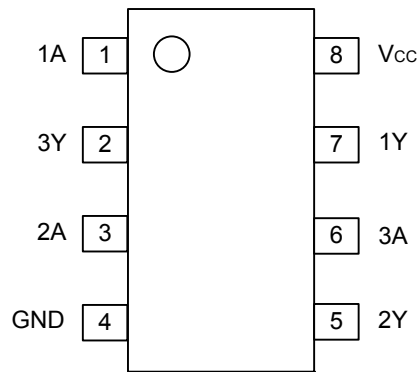

■ FUNCTION TABLE (each gate)

INPUT	OUTPUT
nA	nY
L	L
H	Z

■ LOGIC DIAGRAM (positive logic)

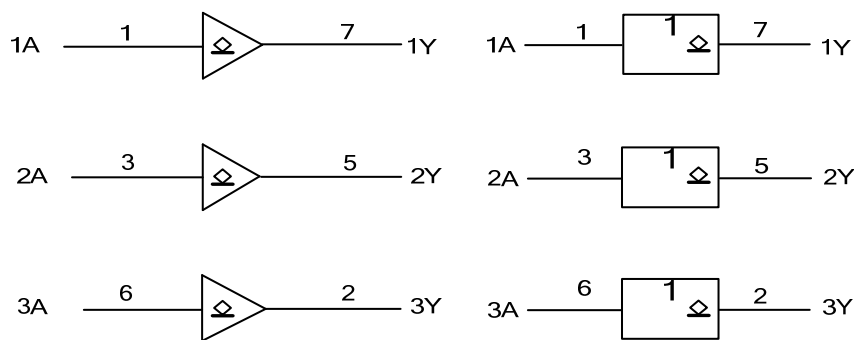

IEC logic symbol

■ ABSOLUTE MAXIMUM RATINGS (unless otherwise specified)

PARAMETER	SYMBOL	RATINGS	UNIT
Supply Voltage	V_{CC}	-0.5~7	V
Output Voltage	V_{OUT}	-0.5~ V_{CC} +0.5(active mode)	V
		-0.5~7.0(high-impedance mode)	V
V_{CC} or GND Current	I_{CC}	50	mA
Input Clamp Current	I_{IK}	±20	mA
Output Clamp Current	I_{OK}	-20	mA
Output Current	I_{OUT}	-25	mA
Power Dissipation	P_D	300	mW
Storage Temperature	T_{STG}	-65 ~ +150	°C

Note: Absolute maximum ratings are those values beyond which the device could be permanently damaged.
Absolute maximum ratings are stress ratings only and functional device operation is not implied.

■ RECOMMENDED OPERATING CONDITIONS

PARAMETER	SYMBOL	CONDITIONS	MIN	TYP	MAX	UNIT
Supply Voltage	V_{CC}		4.5	5.0	5.5	V
Input Voltage	V_{IN}		0		5.5	V
Output Voltage	V_{OUT}		0		V_{CC}	V
Input Rise and Fall Times	t_R, t_F	$V_{CC}=4.5V$		6.0	500	ns
Operating Temperature	T_A		-40	+25	+125	°C

■ STATIC CHARACTERISTICS ($T_A=25^\circ C$)

PARAMETER	SYMBOL	TEST CONDITIONS	MIN	TYP	MAX	UNIT
High-Level Input Voltage	V_{IH}	$V_{CC}= 4.5V\sim 5.5V$	2.0	1.6		V
Low-Level Input Voltage	V_{IL}	$V_{CC}= 4.5V\sim 5.5V$		1.2	0.8	V
Low-Level Output Voltage	V_{OL}	$V_{CC}= 4.5V, I_{OL}=20\mu A$		0	0.1	V
		$V_{CC}= 4.5V, I_{OL}=4.0mA$		0.15	0.33	V
Input Leakage Current	$I_{I(LEAK)}$	$V_{CC}= 5.5V, V_{IN}=V_{CC}$ or GND			±1.0	μA
Output OFF-State Current	I_{OZ}	$V_{CC}= 5.5V, V_{IN}=V_{IH}$ or $V_{IL}; V_{OUT}=V_{CC}$ or GND			±5.0	μA
Quiescent Supply Current	I_Q	$V_{CC}= 5.5V, V_{IN}=V_{CC}$ or GND, $I_{OUT}=0$			10	μA
Additional Quiescent Supply Current	ΔI_Q	$V_{CC}= 4.5V\sim 5.5V, V_{IN}=V_{CC}$ -2.1V; $I_{OUT}=0$			375	μA
Input Capacitance	C_{IN}			1.5		pF

■ DYNAMIC CHARACTERISTICS ($T_A=25^\circ C, t_R, t_F\leq 6.0ns$)

PARAMETER	SYMBOL	TEST CONDITIONS	MIN	TYP	MAX	UNIT
Propagation Delay From nA to nY	t_{PZL}	$V_{CC}=4.5V, C_L= 50 pF$		11	27	ns
	t_{PLZ}	$V_{CC}=4.5V, C_L= 50 pF$		10	26	ns
Output Transition Time	t_{THL}	$V_{CC}=4.5V, C_L= 50 pF$		6	19	ns

■ OPERATING CHARACTERISTICS

PARAMETER	SYMBOL	TEST CONDITIONS	MIN	TYP	MAX	UNIT
Power Dissipation Capacitance	C_{pd}			4		pF

■ TEST CIRCUIT AND WAVEFORMS

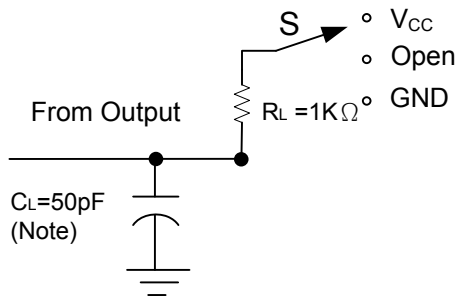

TEST	S
t_{PLH}/t_{PHL}	Open
t_{PHZ}/t_{PZH}	GND
t_{PLZ}/t_{PZL}	V_{CC}

Note: C_L includes probe and jig capacitance.

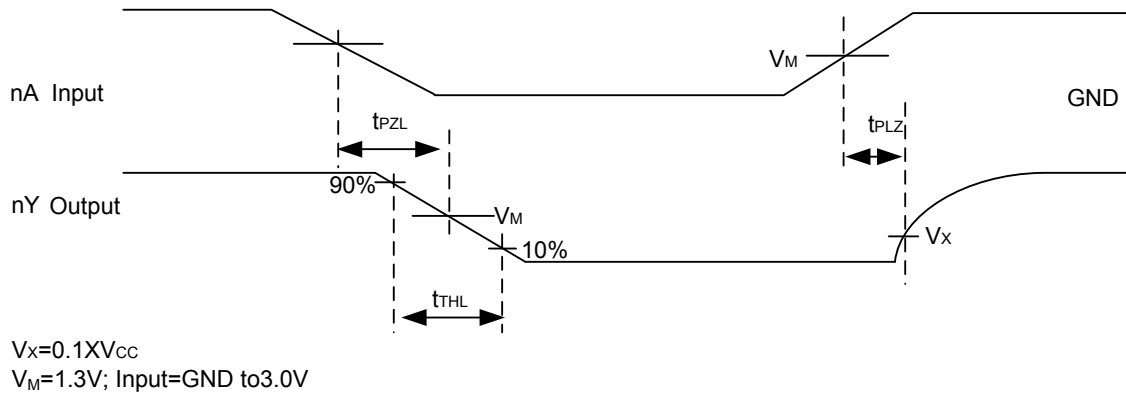

UTC assumes no responsibility for equipment failures that result from using products at values that exceed, even momentarily, rated values (such as maximum ratings, operating condition ranges, or other parameters) listed in products specifications of any and all UTC products described or contained herein. UTC products are not designed for use in life support appliances, devices or systems where malfunction of these products can be reasonably expected to result in personal injury. Reproduction in whole or in part is prohibited without the prior written consent of the copyright owner. The information presented in this document does not form part of any quotation or contract, is believed to be accurate and reliable and may be changed without notice.