



MBR1060C

DIODE

SCHOTTKY BARRIER RECTIFIER DIODES

FEATURES

- * Schottky Barrier Chip
- * Guard Ring Die Construction for Transient Protection
- * Low Power Loss, High Efficiency
- * High Surge Capability
- * High Current Capability and Low Forward Voltage Drop
- * For Use in Low Voltage, High Frequency Inverters, Free Wheeling, and Polarity Protection Applications

SYMBOL

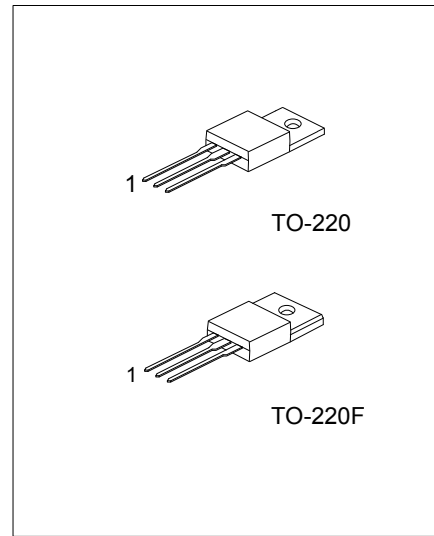
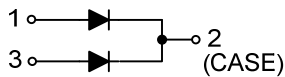

Lead-free: MBR1060CL
Halogen-free: MBR1060CG

ORDERING INFORMATION

Ordering Number			Package	Pin Assignment			Packing
Normal	Lead Free	Halogen Free		1	2	3	
MBR1060C-TA3-T	MBR1060CL-TA3-T	MBR1060CG-TA3-T	TO-220	A	K	A	Tube
MBR1060C-TF3-T	MBR1060CL-TF3-T	MBR1060CG-TF3-T	TO-220F	A	K	A	Tube

Note: Pin Assignment: A: Anode K: Cathode

<p>MBR1060CL-TA3-T</p> <p>(1) Packing Type (2) Package Type (3) Lead Plating</p>	<p>(1) T: Tube (2) TA3: TO-220, TF3: TO-220F (3) G: Halogen Free, L: Lead Free, Blank: Pb/Sn</p>
--	--

■ **ELECTRICAL CHARACTERISTICS RATINGS** (Ta=25°C, unless otherwise specified)

PARAMETER	SYMBOL	RATINGS	UNIT	
Maximum Repetitive Peak Reverse Voltage	V _{RRM}	60	V	
Maximum DC Blocking Voltage	V _R	60	V	
Working Peak Reverse Voltage	V _{RWM}	60	V	
Maximum PMS Reverse Voltage	V _{R(RMS)}	42	V	
Average Forward Rectified Output Current (Note 1)(T _C =105°C)	I _{OUT}	10	A	
Non-Repetitive Peak Forward Surge Current 8.3ms Single Half-Sine-Wave	I _{FSM}	125	A	
Repetitive Peak Reverse Surge Current (t _p ≤ 2.0μs)	I _{RRM}	1.0	A	
Forward Voltage Drop	V _{FM}	I _F =5.0A, T _C =125°C	0.70	V
		I _F =5.0A, T _C =25°C	0.80	V
		I _F =10A, T _C =25°C	0.95	V
Peak Reverse Current at Rated DC Blocking Voltage	I _{RM}	T _C = 25°C	0.1	mA
		T _C =125°C	15	mA
Typical Junction Capacitance (Note 2)	C _J	150	pF	
Operating Temperature	T _J	-65 ~ +150	°C	
Storage Temperature	T _{STG}	-65 ~ +150	°C	

- Notes: 1. Thermal resistance junction to case mounted heat sink.
 2. Measured at 1.0MHz and applied reverse voltage of 4.0V DC.

UTC assumes no responsibility for equipment failures that result from using products at values that exceed, even momentarily, rated values (such as maximum ratings, operating condition ranges, or other parameters) listed in products specifications of any and all UTC products described or contained herein. UTC products are not designed for use in life support appliances, devices or systems where malfunction of these products can be reasonably expected to result in personal injury. Reproduction in whole or in part is prohibited without the prior written consent of the copyright owner. The information presented in this document does not form part of any quotation or contract, is believed to be accurate and reliable and may be changed without notice.