



MBR20200C

Preliminary

DIODE

SCHOTTKY BARRIER RECTIFIERS

DESCRIPTION

The UTC **MBR20200C** is a Schottky Barrier Rectifier with high efficiency, low power dissipation and high current capacity. It can be applied in low voltage, high frequency inverters, polarity protection and free wheeling applications.

FEATURES

- * High surge capability
- * High efficiency, low power dissipation, high current capability, low forward voltage drop

SYMBOL

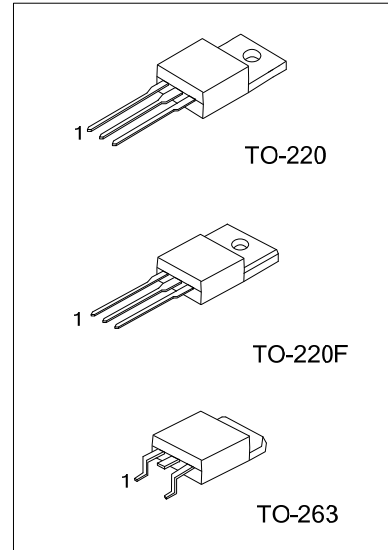
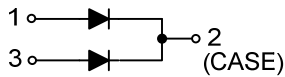

ORDERING INFORMATION

Ordering Number		Package	Pin Assignment			Packing
Lead Free	Halogen Free		1	2	3	
MBR20200CL-TA3-T	MBR20200CG-TA3-T	TO-220	A	K	A	Tube
MBR20200CL-TF3-T	MBR20200CG-TF3-T	TO-220F	A	K	A	Tube
MBR20200CL-TQ2-T	MBR20200CG-TQ2-T	TO-263	A	K	A	Tube
MBR20200CL-TQ2-R	MBR20200CG-TQ2-R	TO-263	A	K	A	Tape Reel

Note: Pin Assignment: A: Anode K: Cathode

<p>MBR20200CL-TA3-T</p>	<p>(1) T: Tube, R: Tape Reel (2) TA3: TO-220, TF3: TO-220F, TQ2: TO-263 (3) G: Halogen Free, L: Lead Free</p>
-------------------------	-------------------------------------------------------------------------------------------------------------------------

■ ABSOLUTE MAXIMUM RATINGS (T_A=25°C, unless otherwise specified)

PARAMETER	SYMBOL	RATINGS	UNIT
Recurrent Peak Reverse Voltage	V _{RRM}	200	V
RMS Voltage	V _{R(RMS)}	140	V
DC Blocking Voltage	V _R	200	V
Average Forward Rectified Output Current	I _{OUT}	20	A
DC Reverse Current (T _C =25°C)	I _R	1.0	mA
Peak Repetitive Forward Current (Rated V _R , Square Wave, 20 kHz) (T _C =135°C)	I _{FRM}	20	A
Non-Repetitive Peak Forward Surge Current 8.3ms Single Half-Sine-Wave	I _{FSM}	150	A
Peak Repetitive Reverse Surge Current (Note 3)	I _{RRM}	1.0	A
Voltage Rate of Change (Rated V _R)	dv/dt	10000	V/μs
Junction Capacitance (Note 4)	C _J	320	pF
Operating Junction Temperature	T _J	+150	°C
Storage Temperature	T _{STG}	-55 ~ +150	°C

■ THERMAL DATA

PARAMETER	SYMBOL	RATINGS	UNIT
Junction to Ambient	θ _{JA}	60	°C/W
Junction to Case	θ _{JC}	4.5	

■ ELECTRICAL CHARACTERISTICS

PARAMETER	SYMBOL	TEST CONDITIONS	MIN	TYP	MAX	UNIT
Instantaneous Forward Voltage Drop (Note 3)	V _F	I _F =10A, T _C =25°C			0.99	V
		I _F =10A, T _C =125°C			0.87	
		I _F =20A, T _C =25°C			1.23	
		I _F =20A, T _C =125°C			1.10	
Instantaneous Reverse Current (Note 3)	I _R	Rated DC Voltage, T _C =25°C			1.0	mA
		Rated DC Voltage, T _C =125°C			50	

Notes: 1. Absolute maximum ratings are those values beyond which the device could be permanently damaged.

Absolute maximum ratings are stress ratings only and functional device operation is not implied.

- 2.0μs Pulse Width, f = 1.0KHz.
- Pulse Test: Pulse Width=300μs, Duty Cycle≤ 2.0%.
- Applied V_R = 4.0V and f = 1.0MHz.

UTC assumes no responsibility for equipment failures that result from using products at values that exceed, even momentarily, rated values (such as maximum ratings, operating condition ranges, or other parameters) listed in products specifications of any and all UTC products described or contained herein. UTC products are not designed for use in life support appliances, devices or systems where malfunction of these products can be reasonably expected to result in personal injury. Reproduction in whole or in part is prohibited without the prior written consent of the copyright owner. The information presented in this document does not form part of any quotation or contract, is believed to be accurate and reliable and may be changed without notice.