



ULTRA FAST-RECOVERY RECTIFIER DIODE

DESCRIPTION

The UTC **BYR79-600** is a rectifier diode providing the designers with ultra-fast switching and low switching loss. It features low forward voltage drop, ultra fast reverse recovery times with very low stored charge and soft-recovery characteristic.

The UTC **BYR79-600** is suitable for switched-mode power supplies, SRPS and high-frequency circuits.

FEATURES

- * Low Switching Loss
- * Low Forward Volt Drop
- * Ultra-Fast Switching
- * Soft Recovery Characteristic
- * Low Thermal Resistance

SYMBOL

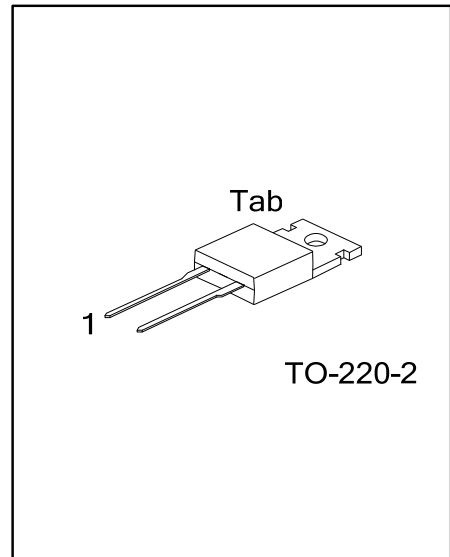
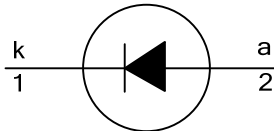

ORDERING INFORMATION

Ordering Number		Package	Pin Assignment			Packing
Lead Free	Halogen Free		1	2	Tab	
BYR79L-600-TA2 -T	BYR79G-600-TA2 -T	TO-220-2	K	A	K	Tube

Note: Pin Assignment: A: Anode, K: Cathode, Tab: Mounting Base

BYR79L-600- TA2 - T (1)Packing Type (2)Package Type (3)Lead Free	(1) T: Tube (2) TA2: TO-220-2 (3) L: Lead Free, G: Halogen Free
---	---

■ ABSOLUTE MAXIMUM RATINGS

PARAMETER	SYMBOL	CONDITIONS	RATINGS	UNIT
Peak Repetitive Reverse Voltage	V_{RRM}		600	V
Crest Working Reverse Voltage	V_{RWM}		600	V
Continuous Reverse Voltage	V_R		600	V
Average Forward Current	$I_{F(AV)}$	Square waveform; $\delta=0.5$; $T_{mb} \leq 108^\circ\text{C}$	15	A
Repetitive Peak Forward Current	I_{FRM}	$t=25\mu\text{s}$; square waveform; $\delta=0.5$; $T_{mb} \leq 108^\circ\text{C}$	30	A
Non-Repetitive Peak Forward Current.	I_{FSM}	$t=10\text{ms}$; sinusoidal waveform	130	A
		$t=8.3\text{ms}$; sinusoidal waveform	143	A
Junction Temperature	T_J		150	$^\circ\text{C}$
Storage Temperature	T_{STG}		-40 ~ +150	$^\circ\text{C}$

Note: Absolute maximum ratings are those values beyond which the device could be permanently damaged.

Absolute maximum ratings are stress ratings only and functional device operation is not implied.

■ THERMAL DATA

PARAMETER	SYMBOL	RATINGS	UNIT
Junction to Ambient	θ_{JA}	60	K/W
Junction to Tab	θ_{JB}	2.0	K/W

■ ELECTRICAL CHARACTERISTICS ($T_J = 25^\circ\text{C}$, unless otherwise specified)

PARAMETER	SYMBOL	TEST CONDITIONS	MIN	TYP	MAX	UNIT
Forward Voltage	V_F	$I_F = 15\text{A}$, $T_J = 150^\circ\text{C}$		1.0	1.2	V
		$I_F = 15\text{A}$, $T_J = 25^\circ\text{C}$		1.17	1.38	V
Reverse Current	I_R	$V_R = 600\text{V}$,		5	50	μA
		$V_R = 600\text{V}$, $T_J = 100^\circ\text{C}$		0.2	0.8	mA
Reverse Recovery Charge	Q_r	$I_F = 2\text{A}$ to $V_R \geq 30\text{V}$, $di_F/dt = 20\text{A}/\mu\text{s}$, $T_J = 25^\circ\text{C}$		40	70	nC
Reverse Recovery Time	t_{RR}	$I_F = 10\text{A}$ to $V_R \geq 30\text{V}$, $di_F/dt = 100\text{A}/\mu\text{s}$, $T_J = 25^\circ\text{C}$		50	60	ns

Note: Measured under pulse conditions to avoid excessive dissipation.

■ TYPICAL CHARACTERISTICS

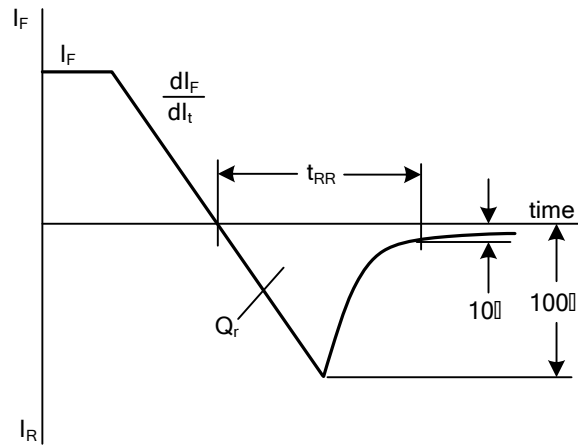

Definition of t_{RR} and Q_r

UTC assumes no responsibility for equipment failures that result from using products at values that exceed, even momentarily, rated values (such as maximum ratings, operating condition ranges, or other parameters) listed in products specifications of any and all UTC products described or contained herein. UTC products are not designed for use in life support appliances, devices or systems where malfunction of these products can be reasonably expected to result in personal injury. Reproduction in whole or in part is prohibited without the prior written consent of the copyright owner. The information presented in this document does not form part of any quotation or contract, is believed to be accurate and reliable and may be changed without notice.