



M4034

LINEAR INTEGRATED CIRCUIT

3-INPUT VIDEO SWITCH

DESCRIPTION

The UTC **M4034** is 3-input video switch selecting one of three input video or audio signals. Its operating supply voltage range is 5 ~ 12V and bandwidth is 10MHz. Crosstalk is 70dB (at 4.43MHz).

FEATURES

- * Operating Voltage: +4.75V ~ +13V
- * 3 Input-1 Output
- * Muting Function available
- * Wide Operating Supply voltage Range: 4.75V ~ 13V
- * Cross-talk 70dB (at 4.43MHz)
- * Muting Function available
- * Bipolar Technology

ORDERING INFORMATION

Order Number		Package	Packing
Lead Free	Halogen Free		
M4034L-D08-T	M4034G-D08-T	DIP-8	Tube
M4034L-G08-T	M4034G-G08-T	SIP-8	Tube
M4034L-S08-R	M4034G-S08-R	SOP-8	Tape Reel
M4034L-S08-T	M4034G-S08-T	SOP-8	Tube
M4034L-SM1-R	M4034G-SM1-R	MSOP-8	Tape Reel

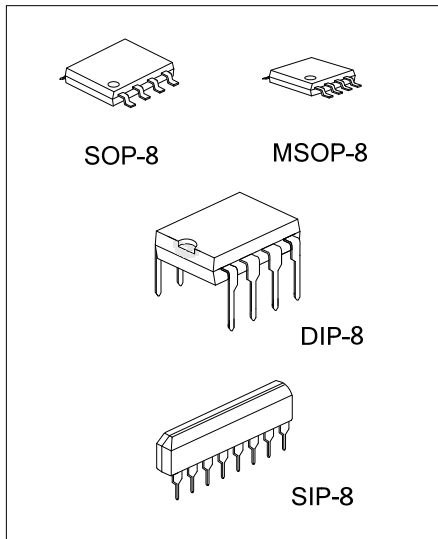

<p>M4034L-D08-T</p> <p>(1)Packing Type (2)Package Type (3)Lead Free</p>	<p>(1) R: Tape Reel, T: Tube (2) D8: DIP-8, G08: SIP-8, S08: SOP-8, SM1: MSOP-8 (3) G: Halogen Free, L: Lead Free</p>
---	---

■ PIN CONFIGURATION

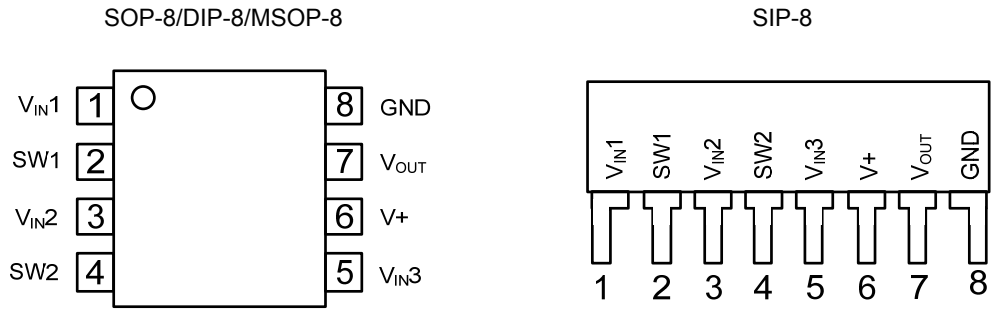

■ BLOCK DIAGRAM

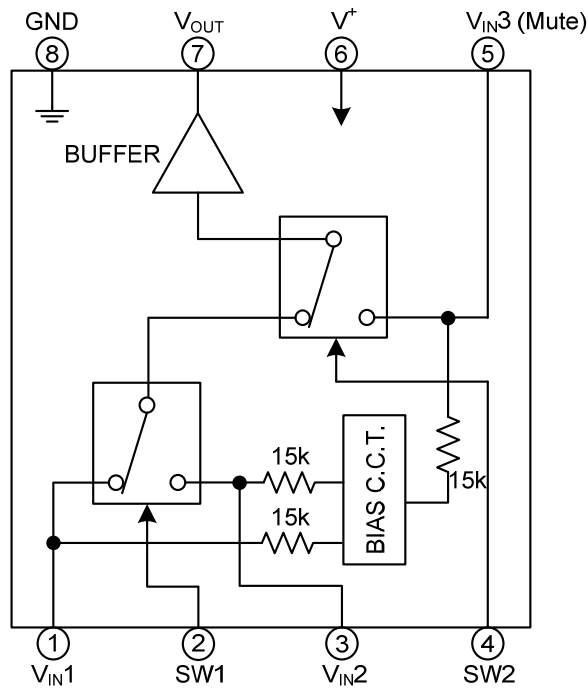

■ ABSOLUTE MAXIMUM RATINGS

PARAMETER		SYMBOL	RATINGS	UNIT
Supply Voltage		V^+	15	V
Power Dissipation	SOP-8	P_D	300	mW
	DIP-8		500	mW
	MSOP-8		250	mW
	SIP-8		800	mW
Junction Temperature		T_J	+125	°C
Operating Temperature		T_{OPR}	-20 ~ +75	°C
Storage Temperature		T_{STG}	-40 ~ +125	°C

Note Absolute maximum ratings are those values beyond which the device could be permanently damaged.

Absolute maximum ratings are stress ratings only and functional device operation is not implied.

■ ELECTRICAL CHARACTERISTICS ($V_{IN}=5V$, $T_a=25^\circ C$)

PARAMETER		SYMBOL	TEST CONDITIONS	MIN	TYP	MAX	UNIT
Recommended Supply Voltage		V^+		4.75		13.0	V
Output Offset Voltage		$V_{O(OFF)}$	(Note 2)	-30		+30	mV
Switch Change Voltage	High	V_{CH}	All inside SW : ON	2.4			V
	Low	V_{CL}	All inside SW : OFF			0.8	V
Operating Current		I_{CC}	S1=S2=S3=S4=S5=1		10.6	14.5	mA
Voltage Gain		G_V	$V_{IN}=2.5V$, 100kHz, V_{OUT}/V_{IN}	-0.5		+0.5	dB
Total Harmonic Distortion		THD	$V_{IN}=2.5V$, 1kHz		0.03		%
Differential Gain		DG	$V_{IN}=2V$, Staircase signal		0		%
Differential Phase		DP	$V_{IN}=2V$, Staircase signal		0		deg
Frequency Characteristic (1)		G_{f1}	$V_{IN}=2.5V$, $V_{OUT}(20Hz)/V_{OUT}(100kHz)$	-1.0		+1.0	dB
Frequency Characteristic (2)		G_{f2}	$V_{IN}=2.0V$, $V_{OUT}(10MHz)/V_{OUT}(100kHz)$	-1.0		+1.0	dB
Crosstalk (1)		CT1	$V_{IN}=2.0V$, 4.43MHz, V_{OUT}/V_{IN} (Note 3)		-70		dB
Crosstalk (2)		CT2	$V_{IN}=2.0V$, 4.43MHz, V_{OUT}/V_{IN} (Note 4)		-70		dB
Input Impedance		R_1			15		k Ω
Output Impedance		R_{OUT}			10		Ω

Note 1: If it is not shown about switch condition, it is tested on three conditions below.

(a) S1=2, S2=S3=S4=S5=1, (b) S2=S4=2, S1=S3=S5=1, (c) S3=S5=2, S1=S2=1, S4=1, or 2.

Note 2: S1=S2=S3=1, Output DC Voltage difference of three mode below.

(a) S4=S5=1, (b) S4=2, S5=1 (c) S4=1 or 2, S5=2

Note 3: S5=1, Tested on all combination of S1 to S4 excepted two below.

(a) S1=S2, S4=1 (b) S2=S4=2

Note 4: Tested on all combination of S1 to S4 excepted one.

(a) S5=2, S3=2

■ EQUIVALENT CIRCUIT

PIN NO.	PIN FUNCTION	INSIDE EQUIVALENT CIRCUIT
1	V _{IN1}	
2	SW1	
3	V _{IN2}	
4	SW2	
5	V _{IN3} (Mute)	
6	V ⁺	
7	V _{OUT}	
8	GND	

■ TEST CIRCUIT

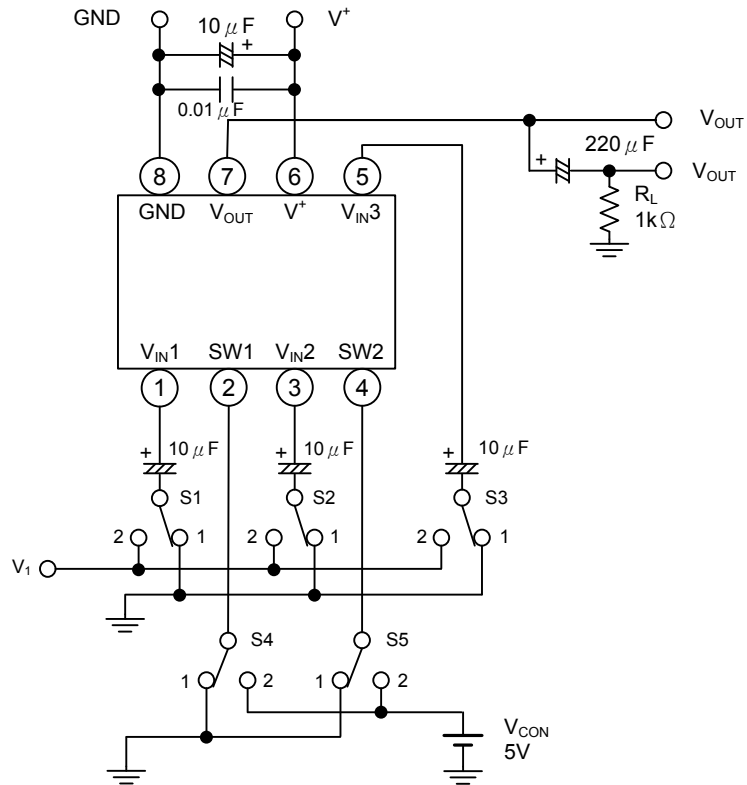

■ CONNECTION DIAGRAM

Terminal Name	V _{IN1}	SW1	V _{IN2}	SW2	V _{IN3}	V ⁺	V _{OUT}	GND
DC Voltage	$\frac{3}{5} V^+$		$\frac{3}{5} V^+$		$\frac{3}{5} V^+$		$\frac{3}{5} V^+ - 0.7$	

■ TYPICAL APPLICATION CIRCUIT

Oscillation Prevention on light loading conditions
 Recommended under circuit

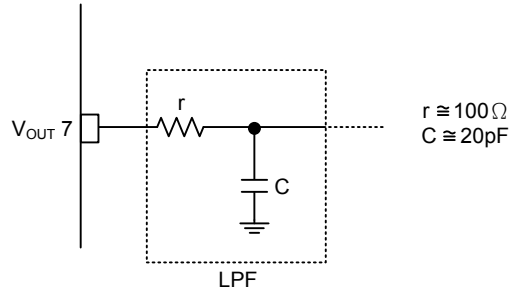

Note: 0.1uF capacitor is required between INPUT and GND for bias type input at mute mode.

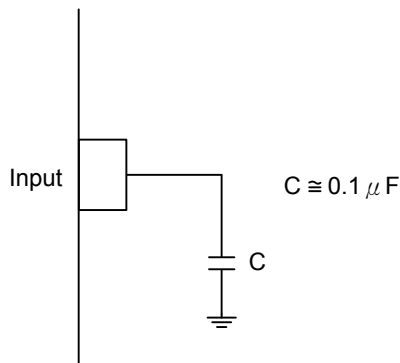

UTC assumes no responsibility for equipment failures that result from using products at values that exceed, even momentarily, rated values (such as maximum ratings, operating condition ranges, or other parameters) listed in products specifications of any and all UTC products described or contained herein. UTC products are not designed for use in life support appliances, devices or systems where malfunction of these products can be reasonably expected to result in personal injury. Reproduction in whole or in part is prohibited without the prior written consent of the copyright owner. The information presented in this document does not form part of any quotation or contract, is believed to be accurate and reliable and may be changed without notice.