



U74AC00

CMOS IC

QUADRUPLE 2-INPUT POSITIVE-NAND GATES

DESCRIPTION

The UTC **U74AC00** contains four independent 2-input NAND gates, and those gates perform the Boolean function of $Y = \overline{A \times B}$ or $Y = \overline{A + B}$ in positive logic.

FEATURES

- * Operation voltage range: 2V ~ 6V
- * Low power dissipation: $I_{CC} = 2\mu A$ (Max)
- * High speed: $t_{pd} = 7ns$ (Typ.) @ 5V
- * Low input current: $0.1\mu A$ (Max) @ 25°C
- * Halogen Free

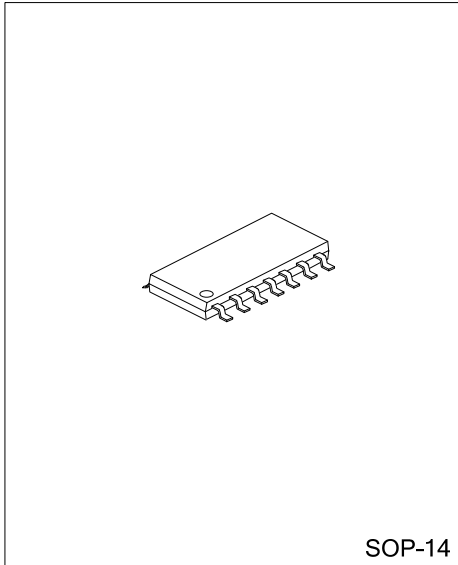

ORDERING INFORMATION

Ordering Number	Package	Packing
U74AC00G-S14-R	SOP-14	Tape Reel

<p>U74AC00G-S14-R</p>	<p>(1) R: Tape Reel</p> <p>(2) S14: SOP-14</p> <p>(3) G: Halogen Free</p>
-----------------------	---

■ PIN CONFIGURATION

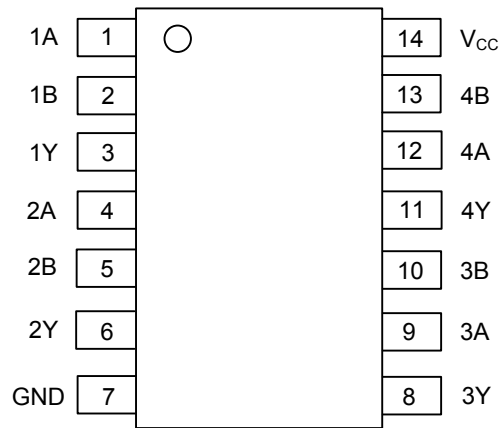

■ FUNCTION TABLE (each gate)

INPUT(A)	INPUT(B)	OUTPUT(Y)
H	H	L
H	L	H
L	H	H
L	L	H

■ LOGIC DIAGRAM (positive logic)

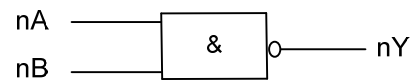
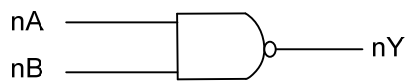

■ ABSOLUTE MAXIMUM RATING (unless otherwise specified)

PARAMETER	SYMBOL	RATINGS	UNIT
Supply Voltage	V_{CC}	-0.5~7	V
Input Voltage	V_{IN}	-0.5 ~ $V_{CC}+0.5$	V
Output Voltage	V_{OUT}	-0.5 ~ $V_{CC}+0.5$	V
Input Clamp Current	I_{IK}	±20	mA
Output Clamp Current	I_{OK}	±20	mA
Output Current	I_{OUT}	±50	mA
V_{CC} or GND Current	I_{CC}	±200	mA
Storage Temperature	T_{STG}	-65 ~ +150	°C

Note: Absolute maximum ratings are those values beyond which the device could be permanently damaged.

Absolute maximum ratings are stress ratings only and functional device operation is not implied.

■ THERMAL DATA

PARAMETER	SYMBOL	MIN	TYP	MAX	UNIT
Junction to Case	θ_{JA}			76	°C/W

■ RECOMMENDED OPERATING CONDITIONS

PARAMETER	SYMBOL	MIN	TYP	MAX	UNIT
Supply Voltage	V_{CC}	2		6	V
Input Voltage	V_{IN}	0		V_{CC}	V
Output Voltage	V_{OUT}	0		V_{CC}	V
Input Transition Rise or Fall Rate	t_R, t_F			8	ns/V
Operating Temperature	T_A	-40		85	°C

■ STATIC CHARACTERISTICS ($T_a = 25^\circ\text{C}$)

PARAMETER	SYMBOL	TEST CONDITIONS	MIN	TYP	MAX	UNIT
High-Level Input Voltage	V_{IH}	$V_{CC} = 3\text{V}$	2.1			V
		$V_{CC} = 4.5\text{V}$	3.15			V
		$V_{CC} = 5.5\text{V}$	3.85			V
Low-Level Input Voltage	V_{IL}	$V_{CC} = 3\text{V}$			0.9	V
		$V_{CC} = 4.5\text{V}$			1.35	V
		$V_{CC} = 5.5\text{V}$			1.65	V
High-Level Output Voltage	V_{OH}	$V_{CC} = 3\text{V}, I_{OH} = -50\mu\text{A}$	2.9			V
		$V_{CC} = 4.5\text{V}, I_{OH} = -50\mu\text{A}$	4.4			V
		$V_{CC} = 5.5\text{V}, I_{OH} = -50\mu\text{A}$	5.4			V
		$V_{CC} = 3\text{V}, I_{OH} = -12\text{mA}$	2.56			V
		$V_{CC} = 4.5\text{V}, I_{OH} = -24\text{mA}$	3.86			V
		$V_{CC} = 5.5\text{V}, I_{OH} = -24\text{mA}$	4.86			V
		$V_{CC} = 5.5\text{V}, I_{OH} = -75\text{mA}$	3.85			V
Low-Level Output Voltage	V_{OL}	$V_{CC} = 3\text{V}, I_{OL} = 50\mu\text{A}$		0.002	0.1	V
		$V_{CC} = 4.5\text{V}, I_{OL} = 50\mu\text{A}$		0.001	0.1	V
		$V_{CC} = 5.5\text{V}, I_{OL} = 50\mu\text{A}$		0.001	0.1	V
		$V_{CC} = 3\text{V}, I_{OL} = 12\text{mA}$			0.36	V
		$V_{CC} = 4.5\text{V}, I_{OL} = 24\text{mA}$			0.36	V
		$V_{CC} = 5.5\text{V}, I_{OL} = 24\text{mA}$			0.36	V
		$V_{CC} = 5.5\text{V}, I_{OL} = 75\text{mA}$			1.65	V
Input Leakage Current	$I_{I(LEAK)}$	$V_{CC} = 5.5\text{V}, V_{IN} = V_{CC}$ or GND			0.1	μA
Quiescent Supply Current	I_Q	$V_{CC} = 5.5\text{V}, V_{IN} = V_{CC}$ or GND, $I_{OUT} = 0$			2	μA
Input Capacitance	C_{IN}	$V_{CC} = 5\text{V}, V_{IN} = V_{CC}$ or GND		2.6		pF

■ **DYNAMIC CHARACTERISTICS** (Ta=25°C, Input: tr=tf=2.5ns, unless otherwise specified)

PARAMETER	SYMBOL	TEST CONDITIONS	MIN	TYP	MAX	UNIT
Propagation delay from Input(A or B) to Output(Y)	t _{PLH}	V _{CC} =3.3V±0.3V, C _L =50pf, R _L =500Ω	2	7	9.5	ns
		V _{CC} =5V±0.5V, C _L =50pF, R _L =500Ω	1.5	6	8	ns
	t _{PHL}	V _{CC} =3.3V±0.3V, C _L =50pf, R _L =500Ω	1.5	5.5	8	ns
		V _{CC} =5V±0.5V, C _L =50pF, R _L =500Ω	1.5	4.5	6.5	ns

■ **OPERATING CHARACTERISTICS** (Ta=25°C, unless otherwise specified)

PARAMETER	SYMBOL	TEST CONDITION	MIN	TYP	MAX	UNIT
Power Dissipation Capacitance	Cpd	C _L =50pF, f=1MHz		40		pF

■ TEST CIRCUIT AND WAVEFORMS

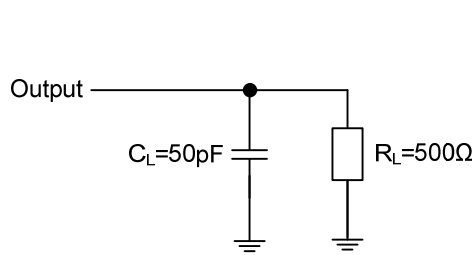

Definitions for test circuit

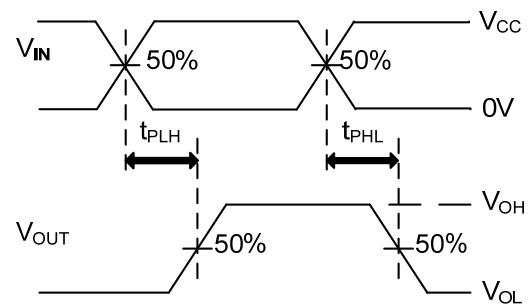

Propagation Delay Times

Note: C_L includes probe and jig capacitance.
 $PRR \leq 1\text{MHz}$, $Z_O = 50\Omega$, $t_r \leq 2.5\text{ns}$, $t_f \leq 2.5\text{ns}$.

UTC assumes no responsibility for equipment failures that result from using products at values that exceed, even momentarily, rated values (such as maximum ratings, operating condition ranges, or other parameters) listed in products specifications of any and all UTC products described or contained herein. UTC products are not designed for use in life support appliances, devices or systems where malfunction of these products can be reasonably expected to result in personal injury. Reproduction in whole or in part is prohibited without the prior written consent of the copyright owner. The information presented in this document does not form part of any quotation or contract, is believed to be accurate and reliable and may be changed without notice.