

UTC 1470

LINEAR INTEGRATED CIRCUIT

MOTOR SPEED REGULATORS

DESCRIPTION

The UTC 1470 is a monolithic integrated circuit intended as speed regulators for DC motors of record players, tape and cassette recorders etc .

FEATURES

- *Excellent Versatility in use.
- *High Output current.
- *Low Quiescent current.
- *Low Reference voltage.
- *Excellent parameters stability versus temperature.
- *Excellent characteristic at low supply voltage.

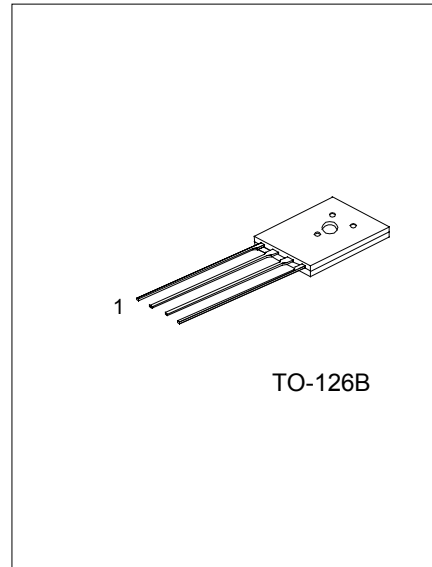

1: Vcc 2: Rt 3: GND 4: MOTOR

BLOCK DIAGRAM

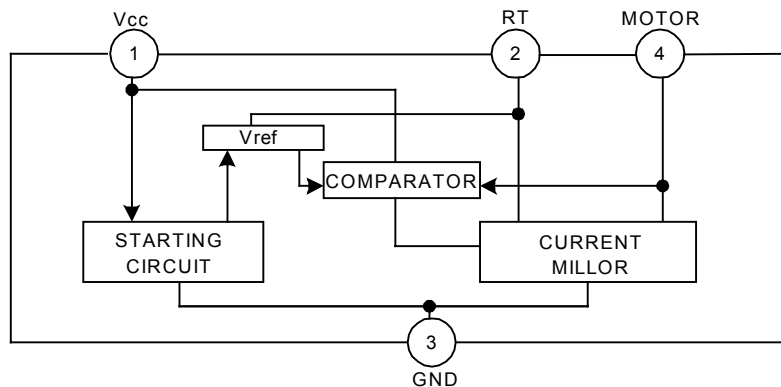

ABSOLUTE MAXIMUM RATINGS (Ta=25°C)

PARAMETER	SYMBOL	RATING	UNIT
Supply Voltage	Vcc	18	V
Circuit Current	I ₄	2*	A
Package Dissipation	PD	1.2	W
Operating Temperature	Topt	-20 ~ +75	°C
Storage Temperature	TSTG	-40 ~ +150	°C
		*t ≤ 5s	

RECOMMENDED OPERATING CONDITION

PARAMETER	SYMBOL	RATING	UNIT
Supply Voltage Range	V _{CC}	3.5 ~ 16	V

ELECTRICAL CHARACTERISTICS (T_a=25°C, V_{CC}=12V)

CHARACTERISTIC	SYMBOL	TEST CONDITIONS	MIN	TYP	MAX	UNIT
Reference Voltage	V _{ref}	I ₄ =10mA (Fig.1)	1.10	1.27	1.40	V
Quiescent Current	I _d	R _M =180Ω (Fig.4)	0.5	0.8	1.2	mA
Reflection Coefficient	k	R _{M1} =44Ω, R _{M2} =33Ω (Fig.2)	18	20	22	
Saturation Voltage	V _{4(sat)}	V _{CC} =4.2V, R _M =4.4Ω (Fig.3)		1.5	2.0	V
	$\frac{\Delta k}{k} / \Delta V_{CC}$	I ₄ =100mA, V _{CC} =6.3~16V (Fig.2)		0.4		%/V
Line Regulation	$\frac{\Delta V_{ref}}{V_{ref}} / \Delta V_{CC}$	I ₄ =100mA, V _{CC} =6.3~16V (Fig.1)		0.06		%/V
	$\frac{\Delta k}{k} / \Delta I_M$	I ₄ =30~200mA (Fig.2)		-0.02		%/mA
Load Regulation	$\frac{\Delta V_{ref}}{V_{ref}} / \Delta I_M$	I ₄ =30~200mA (Fig.1)		-0.02		%/mA
	$\frac{\Delta k}{k} / \Delta T_a$	I ₄ =100mA, T _a =-20~+75°C (Fig.2)		0.01		%/°C
Temperature Coefficient	$\frac{\Delta V_{ref}}{V_{ref}} / \Delta T_a$	I ₄ =100mA, T _a =-20~+75°C (Fig.1)		0.01		%/°C

*Pulse Test::PW≤10ms,Duty cycle≤2%

TEST CIRCUIT

Fig.1

$$\left(V_{ref}, \frac{\Delta V_{ref}}{V_{ref}} / \Delta V_{CC}, \frac{\Delta V_{ref}}{V_{ref}} / \Delta I_4, \frac{\Delta V_{ref}}{V_{ref}} / \Delta T_a \right)$$

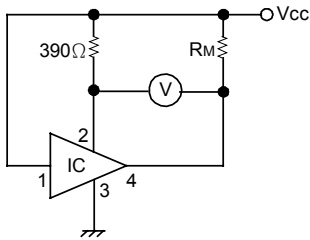
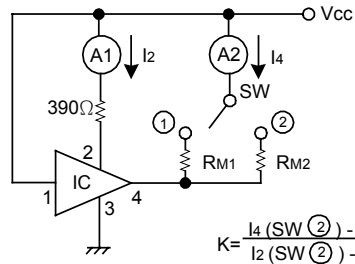

Fig.2

$$\left(k, \frac{\Delta k}{k} / \Delta V_{CC}, \frac{\Delta k}{k} / \Delta I_4, \frac{\Delta k}{k} / \Delta T_a \right)$$



UTC 1470 LINEAR INTEGRATED CIRCUIT

Fig.3 (V_{4(sat)})

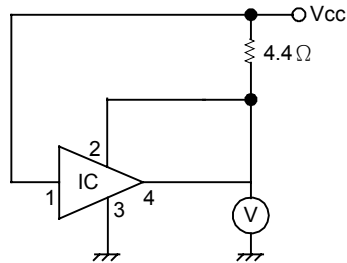
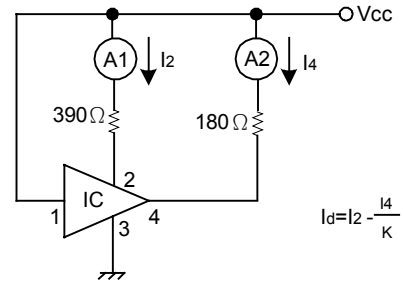
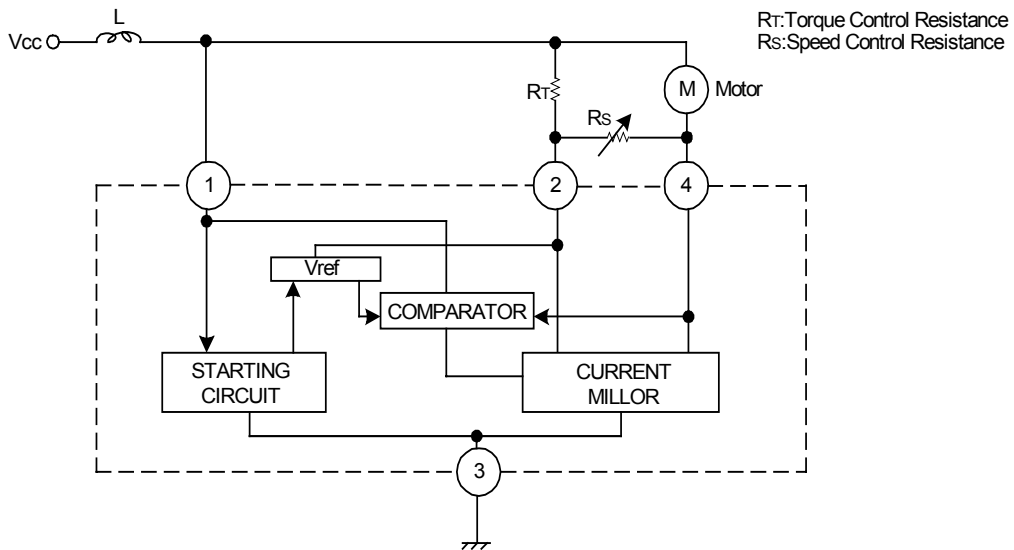

Fig.4 (I_d)



$$I_d = I_2 - \frac{I_4}{K}$$

APPLICATION INFORMATION



UTC 1470 LINEAR INTEGRATED CIRCUIT

BASIC EQUATION FOR MOTOR

$$\begin{cases} E_t = V_{ref} + R_T (i_2 + \frac{V_{ref}}{R_s}) \\ i_2 = \frac{1}{K} i_4 + i_q \\ i_4 = i_m + \frac{V_{ref}}{R_s} \end{cases}$$

$$E_t = V_{ref} + R_T (\frac{1}{K} i_4 + i_q + \frac{V_{ref}}{R_s})$$

$$E_t = V_{ref} + R_T \{ \frac{1}{K} (i_m + \frac{V_{ref}}{R_s}) + i_q + \frac{V_{ref}}{R_s} \}$$

$$E_t = V_{ref} \{ 1 + \frac{R_T}{R_s} (1 + \frac{1}{K}) \} + R_T i_q + \frac{R_T}{K} i_m$$

They also give : $E_m = E_o + R_m i_m$

$$\begin{cases} E_o = V_{ref} \{ 1 + \frac{R_T}{R_s} (1 + \frac{1}{K}) \} + R_T i_q \\ R_m = \frac{R_T}{K} \end{cases}$$

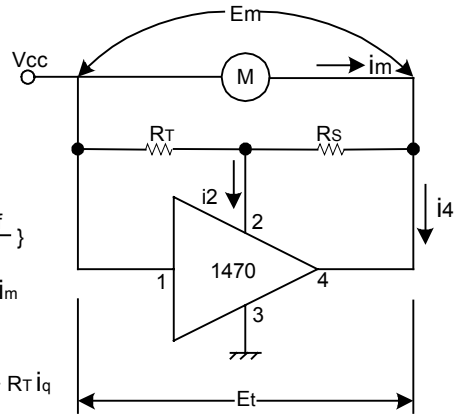

E_o : Back Electromotive Force
 R_m : internal Resistance (of the Motor)
 K : Reflection Coefficient = (i_4 / i_2)

APPLICATION CIRCUIT

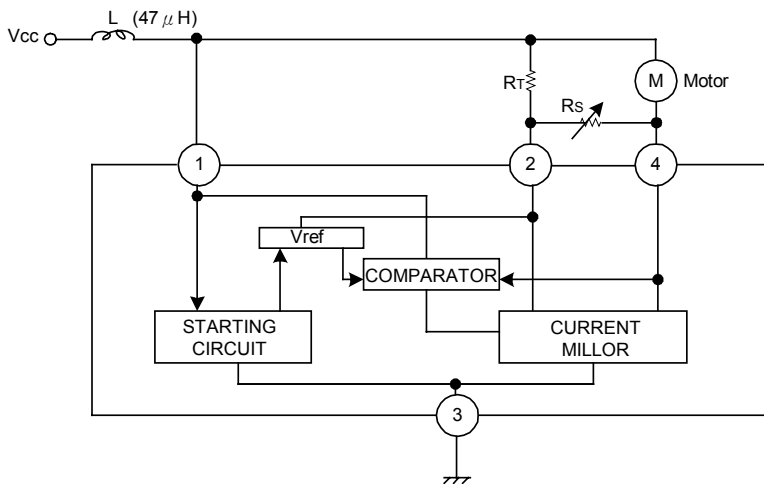

$V_{cc} = 12V$
 $R_m = 19.5 \Omega$
 $R_T = 330 \Omega$
 $R_s = 1k \Omega$
 $E_o = 2.3V$
 $K = 20$

Note 1. The motor speed can be adjusted by the variable resistor R_s .

$$R_{smin} = \frac{V_{ref} \cdot R_T}{E_o - V_{ref} - i_q \cdot R_T}$$

Note 2. If $R_{Tmax} > K \cdot R_{min}$, instability of the motor may occur.

UTC assumes no responsibility for equipment failures that result from using products at values that exceed, even momentarily, rated values (such as maximum ratings, operating condition ranges, or other parameters) listed in products specifications of any and all UTC products described or contained herein. UTC products are not designed for use in life support appliances, devices or systems where malfunction of these products can be reasonably expected to result in personal injury. Reproduction in whole or in part is prohibited without the prior written consent of the copyright owner. The information presented in this document does not form part of any quotation or contract, is believed to be accurate and reliable and may be changed without notice.