



AN8850

Preliminary

CMOS IC

MOTOR CONTROL CIRCUITS

DESCRIPTION

The UTC **AN8850** is a electronic governor suitable for low-voltage and compact DC motors generally used in the tape recorder, etc.

FEATURES

- * Wide range of operating voltage : $V_{CC(opr)} = 1.8V \sim 12V$
- * 2 package types
- * Fewer external parts
- * Speed control in steps with linear fine control

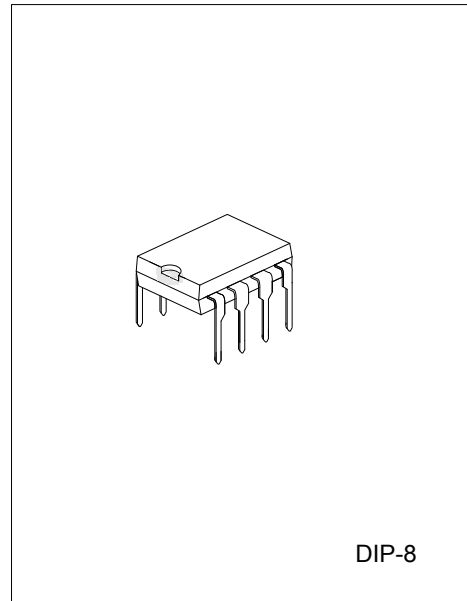

ORDERING INFORMATION

Ordering Number		Package	Packing
Lead Free	Halogen Free		
AN8850L-D08-T	AN8850G-D08-T	DIP-8	Tube

Note: xx: Output Voltage, refer to Marking Information.

<p>AN8850L-D08-T</p> <p>(1) Packing Type (2) Package Type (3) Lead Free</p>	<p>(1) T: Tube (2) D08: DIP-8 (3) Halogen Free, L: Lead Free</p>
---	--

■ PIN CONFIGURATION

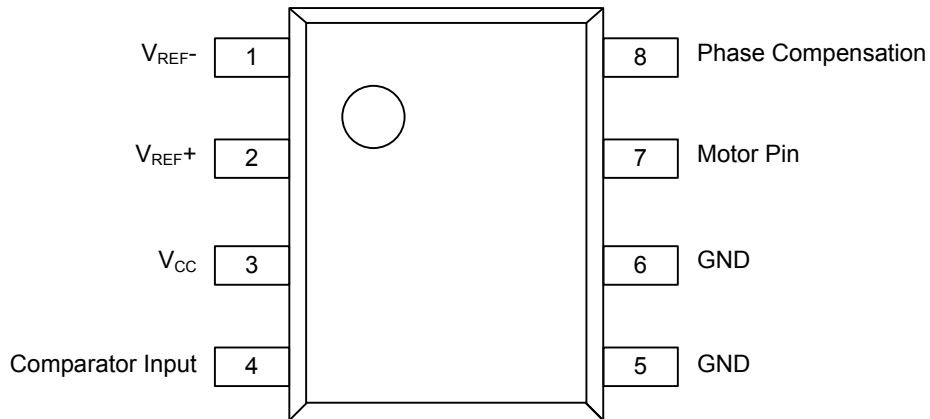

■ PIN DESCRIPTION

PIN NO.	PIN NAME	DESCRIPTION
1	V _{REF-}	V _{REF-}
2	V _{REF+}	V _{REF+}
3	V _{CC}	Power Supply
4	Comparator Input	Input of Comparator
5	GND	Ground
6	GND	Ground
7	Motor Pin	Output Pin
8	Phase Compensation	Phase Compensation

■ BLOCK DIAGRAM

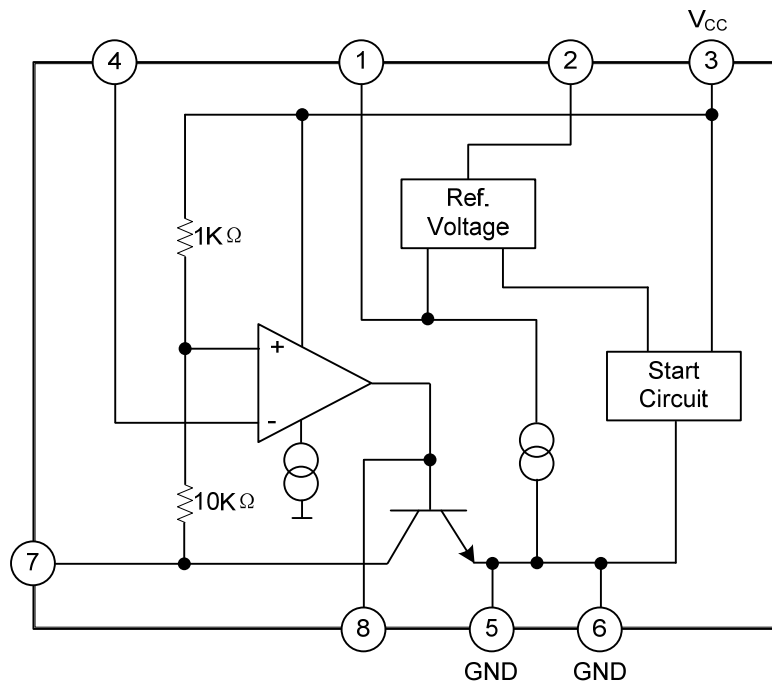

■ ABSOLUTE MAXIMUM RATING (Ta= 25°C)

PARAMETER	SYMBOL	RATINGS	UNIT
Supply Voltage	V_{CC}	12	V
Circuit Voltage	$V_{n-5,6}$ (n = 1, 2, 3, 4)	-0.5~7.5	V
Circuit Voltage	$V_{n-5,6}$	-0.5~1	V
Supply Current	I_{CC} (Note 1)	2	A
Circuit Current	I_{OUT}	2	A
Power Dissipation	P_D	750	mW
Operating Ambient Temperature	T_{OPR}	-20~+75	°C
Storage Temperature	T_{STG}	-40~+150	°C

Notes: Absolute maximum ratings are those values beyond which the device could be permanently damaged.

Absolute maximum ratings are stress ratings only and functional device operation is not implied.

1. $t \leq 5\mu s$

■ ELECTRICAL CHARACTERISTICS (Ta= 25°C)

PARAMETER	SYMBOL	TEST CONDITIONS	MIN	TYP	MAX	UNIT
Supply Current	I_{CC}	$V_{CC}=3V$		2	3	mA
Reference Voltage	V_{ref}	$V_{CC}=3V, V_{2-1}>10k\Omega$	1.20	1.28	1.35	V
Starting Voltage	$V_{CC(s)}$	Supply voltage in which 30mA current flows to Ra		1.0	1.2	V
Saturation Voltage	V_{SAT}	$V_{CC}=1.8V, R_a=4.7\Omega$		0.2	0.5	V
Voltage Characteristics 1	$\frac{\Delta V_{ref}}{V_{ref}} / \Delta V_{CC}$	$V_{CC}= 1.8V \sim 12V$	-1.25	0.1	1.25	%V
Voltage Characteristics 2	$\frac{\Delta V_a}{V_a} / \Delta V_{CC}$	$V_{CC}= 1.8V \sim 12V$	-1.2	0.1	1.2	%V
Current Characteristics	$\frac{\Delta V_{ref}}{V_{ref}} / \Delta I_{OUT}$	$I_{OUT}=1\sim 20mA$	-0.2	0.01	0.2	%mA
Current Characteristics	$\frac{\Delta V_{ref}}{V_{ref}} / \Delta Ta$	$Ta=-20\sim +60^\circ C, V_{CC}=3.0V$		0.01		%°C

Note: Operating Supply Voltage Range : $V_{CC (opr)} = 1.8V \sim 12V$

■ TYPICAL APPLICATION CIRCUIT

Speed Control Circuit with 3V Core Motor

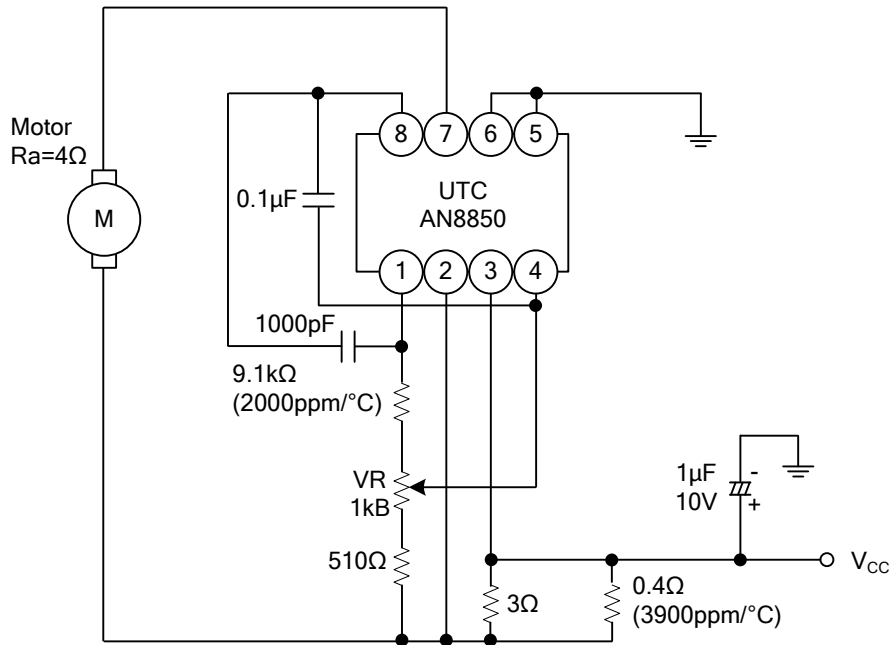

- Motor Constants
- R_a : Internal resistor = 4Ω
 - K_a : Electromotive force constant = 0.4mV/rpm
 - K_T : Torque constant = $30\text{g} \cdot \text{cm/A}$

UTC assumes no responsibility for equipment failures that result from using products at values that exceed, even momentarily, rated values (such as maximum ratings, operating condition ranges, or other parameters) listed in products specifications of any and all UTC products described or contained herein. UTC products are not designed for use in life support appliances, devices or systems where malfunction of these products can be reasonably expected to result in personal injury. Reproduction in whole or in part is prohibited without the prior written consent of the copyright owner. The information presented in this document does not form part of any quotation or contract, is believed to be accurate and reliable and may be changed without notice.