



# KA8602

## LINEAR INTEGRATED CIRCUIT

### LOW VOLTAGE AUDIO POWER AMPLIFIER

#### DESCRIPTION

The UTC **KA8602** is the audio power amplifier available for low voltage. The UTC **KA8602** supplies differential outputs for maximizing output swing at low voltages. The UTC **KA8602** does not need coupling capacitors to the speaker. The gain of this amplifier is controlled easily by two external resistors.

#### FEATURES

- \*Wide operating supply voltage:  $V_{CC}=2V\sim 16V$
- \*Low quiescent supply current(  $I_{CC}=2.7mA$ , typ)
- \*Medium output power ( $P_{OUT}=250mW$  at  $V_{CC}=6V$ ,  $R_L=32ohm$ , THD=10%)
- \*Load impedance range: 8~100ohm
- \*Mute function ( $I_{CC}=65\mu A$ , typ)
- \*Minimum number of external parts required.
- \*Low distortion

#### ORDERING INFORMATION

Ordering Number		Package	Packing
Lead Free	Halogen Free		
KA8602L-D08-T	KA8602G-D08-T	DIP-8	Tube
KA8602L-S08-R	KA8602G-S08-R	SOP-8	Tape Reel
KA8602L-S08-T	KA8602G-S08-T	SOP-8	Tube

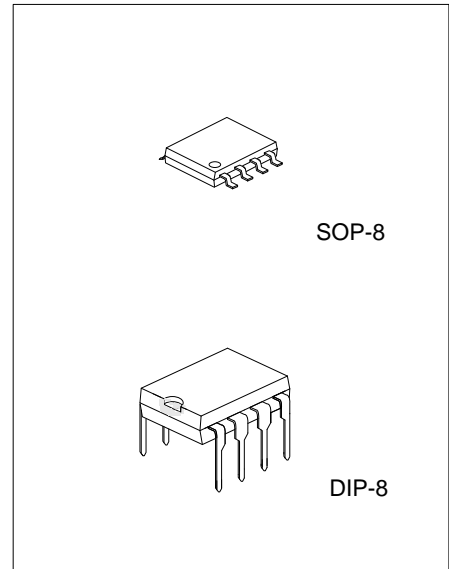

<p>KA8602L-D08-T</p> <p>(1)Packing Type</p> <p>(2)Package Type</p> <p>(3)Lead Free</p>	<p>(1) R: Tape Reel, T: Tube</p> <p>(2) D08: DIP-8, S08: SOP-8</p> <p>(3) G:Halogen Free, L: Lead Free</p>
--	--

### ■ PIN CONFIGURATIONS

PIN	NAME	DESCRIPTION
1	Input(+)	Analog Ground for the amplifiers. A 1 $\mu$ F capacitor at this pin (with a 5 $\mu$ F capacitor at pin 8) provides 52dB (typ) of power supply rejection. Turn-on time of the circuit is affected by the capacitor on this pin. This pin can be used as an alternative input.
2	Input(-)	Amplifier input. The input capacitor and resistor set low frequency roll-off and input impedance. The feedback resistor is connected between this pin and output 1.
3	Output 1	Amplifier 1's output. The DC level is about $(V_{CC}-0.7V)/2$ .
4	V <sub>CC</sub>	DC supply voltage is applied to this pin ( $V_{CC}=2\sim 16V$ ).
5	GND	Ground pin.
6	Output 2	Amplifier 2's output. This signal is equal in amplitude, but 180° out of phase with that output 1, the DC level is about $(V_{CC}-0.7V)/2$ .
7	Mute	This pin can be used to power down the IC to conserve power, or for muting, or both. When at a logic "LOW" (less than 0.8V), the IC is enabled for normal operation. When at a logic "HIGH" (2V to V <sub>CC</sub> ), the IC is disabled. If Mute is open, that is equivalent to a logic "LOW".
8	Ripple Rejection	A capacitor at this pin increase power supply rejection, and affects turn-on time. This pin can be left open if the capacitor at pin 1 is sufficient.

## ■ BLOCK DIAGRAM

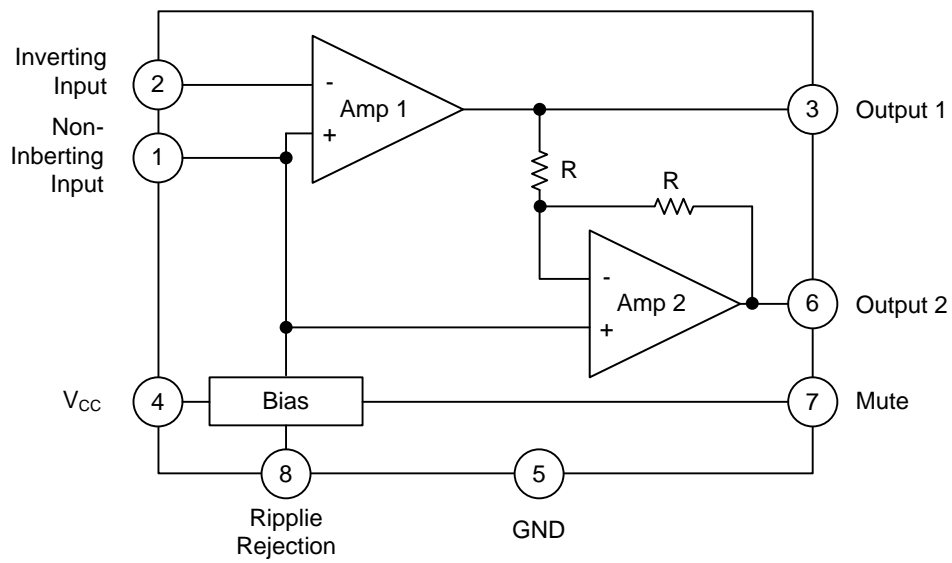

## ■ ABSOLUTE MAXIMUM RATINGS (T<sub>A</sub>=25°C)

PARAMETER	SYMBOL	RATINGS	UNIT
Supply Voltage	V <sub>CC</sub>	-1~18	V
Output Current	I <sub>OUT</sub>	+250	mA
Maximum Input, Ripple Rejection, Mute Pin Voltage	V <sub>I(max)</sub>	-1~V <sub>CC</sub> +1	V
Applied Output Voltage( Output Pin When Disabled)	V <sub>OUT</sub>	-1~V <sub>CC</sub> +1	V
Temperature Junction	T <sub>J</sub>	-55 ~ +150	°C

Note: Absolute maximum ratings are those values beyond which the device could be permanently damaged. Absolute maximum ratings are stress ratings only and functional device operation is not implied.

## ■ RECOMMENDED OPERATION CONDITIONS (T<sub>A</sub>=25°C)

PARAMETER	SYMBOL	RATINGS	UNIT
Supply Voltage	V <sub>CC</sub>	2~16	V
Voltage at Mute	V <sub>I(MUTE)</sub>	0~V <sub>CC</sub>	V
Peak Load Current	I <sub>L(PEAK)</sub>	±200	mA
Load Impedance	Z <sub>L</sub>	8~100	Ω
Differential Gain (5KHz Bandwidth)	ΔG <sub>V</sub>	0~46	dB
Ambient Temperature	T <sub>A</sub>	-20~+70	°C

## ■ ELECTRICAL CHARACTERISTICS (V<sub>CC</sub>=6V, T<sub>A</sub>=25°C, unless otherwise specified)

PARAMETER	SYMBOL	TEST CONDITIONS	MIN	TYP	MAX	UNIT
<b>DC PARAMETER</b>						
Operating Current	I <sub>CC</sub>	V <sub>CC</sub> =3V, Mute=0.8V		2.7	4	mA
		V <sub>CC</sub> =16V, Mute=0.8V		3.3	5	mA
		V <sub>CC</sub> =3V, Mute=2V		65	100	μA
Output Voltage	V <sub>OUT</sub>	V <sub>CC</sub> =3V, R <sub>L</sub> =16Ω, R <sub>1</sub> =75KΩ	1	1.15	1.25	V
		V <sub>CC</sub> =6V, R <sub>L</sub> =16Ω, R <sub>1</sub> =75KΩ		2.65		V
		V <sub>CC</sub> =12V, R <sub>L</sub> =16Ω, R <sub>1</sub> =75KΩ		5.65		V
Output Offset Voltage	V <sub>O(OFF)</sub>	V <sub>CC</sub> =6V, R <sub>F</sub> =75KΩ, R <sub>L</sub> =32Ω	-30	0	30	mV
Output High Level	V <sub>OH</sub>	2V<V <sub>CC</sub> <16V, I <sub>OUT</sub> =-75mA		V <sub>CC</sub> -1		V
Output Low Level	V <sub>OL</sub>	2V<V <sub>CC</sub> <16V, I <sub>OUT</sub> =75mA		0.16		V
Input Bias Current	I <sub>I(BIAS)</sub>			-100	-200	nA
Equivalent Resistance	R <sub>EQ</sub>	Pin 1	100	150	220	KΩ
		Pin 8	18	25	40	KΩ
<b>AC PARAMETER</b>						
Open Loop Gain of Amp. 1	G <sub>V1</sub>		80			dB
Open Loop Gain of Amp. 2	G <sub>V2</sub>	f=1KHz, R <sub>L</sub> =32Ω	-0.35	0	0.35	dB
Output Power	P <sub>OUT</sub>	V <sub>CC</sub> =3V, R <sub>L</sub> =6Ω, THD<10%	55			mW
		V <sub>CC</sub> =6V, R <sub>L</sub> =32Ω, THD<10%	250			mW
		V <sub>CC</sub> =12V, R <sub>L</sub> =100Ω, THD<10%	400			mW
Total Harmonic Distortion (f=1KHz)	THD	V <sub>CC</sub> =6V, R <sub>L</sub> =32Ω, P <sub>OUT</sub> =125mW		0.5	1	%
		V <sub>CC</sub> <3V, R <sub>L</sub> =8Ω, P <sub>OUT</sub> =20mW		0.5		%
		V <sub>CC</sub> <12V, R <sub>L</sub> =32Ω, P <sub>OUT</sub> =200mW		0.6		%
Gain Bandwidth Product	GBW			1.5		MHz
Power Supply Rejection (V <sub>CC</sub> =6V, ΔV <sub>CC</sub> =3V)	PSRR	C <sub>1</sub> =∞, C <sub>2</sub> =0.01μF	50			dB
		C <sub>1</sub> =0.1μF, C <sub>2</sub> =0, f=1KHz		12		dB
		C <sub>1</sub> =1μF, C <sub>2</sub> =5μF, f=1KHz		52		dB
Muting	G <sub>V(MUTE)</sub>	Mute=2V, 1KHz<f<20KHz	70			dB

## APPLICATION CIRCUIT

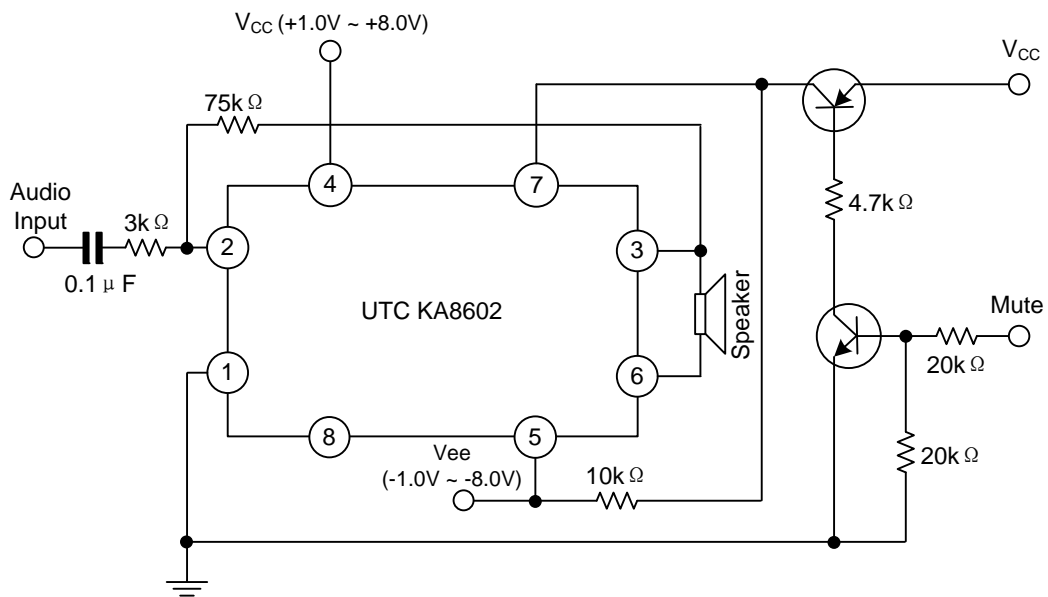
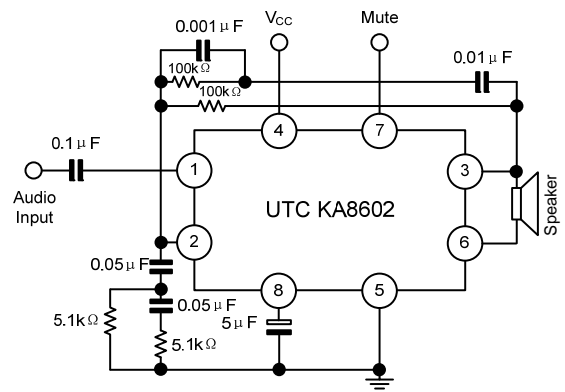
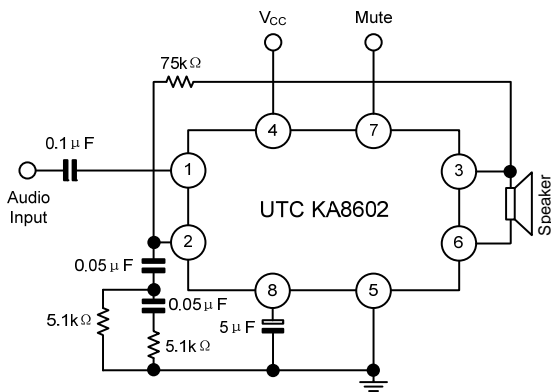
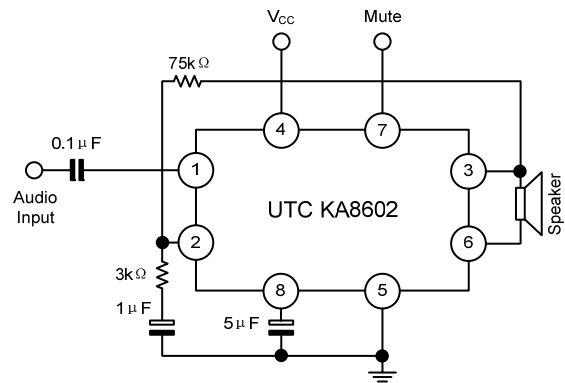
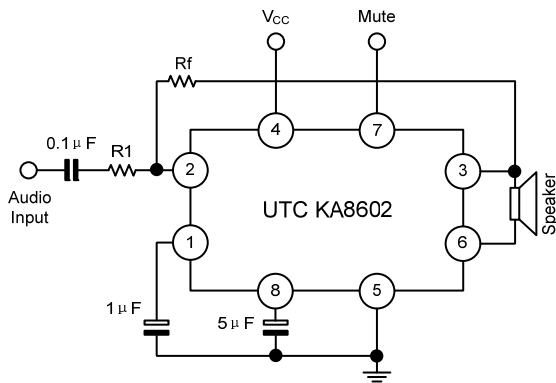

UTC assumes no responsibility for equipment failures that result from using products at values that exceed, even momentarily, rated values (such as maximum ratings, operating condition ranges, or other parameters) listed in products specifications of any and all UTC products described or contained herein. UTC products are not designed for use in life support appliances, devices or systems where malfunction of these products can be reasonably expected to result in personal injury. Reproduction in whole or in part is prohibited without the prior written consent of the copyright owner. The information presented in this document does not form part of any quotation or contract, is believed to be accurate and reliable and may be changed without notice.