



3404

LINEAR INTEGRATED CIRCUIT

DUAL OPERATIONAL AMPLIFIER

DESCRIPTION

The UTC **3404** is high performance single supply dual operational amplifier.

The UTC **3404** is improved version of the UTC M2904 on slew rate & cross-over distortion.

FEATURES

- *Single Supply
- *Operating Voltage: +4v~+36v
- *Low Operating Current: 2.0mA (Typ.)
- *Slew Rate: 1.2V/μs (typ.)

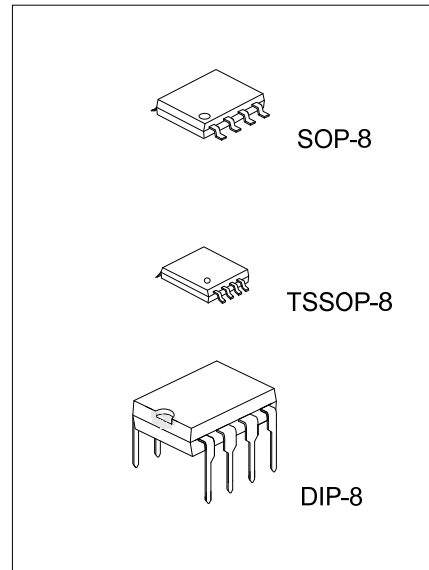

ORDERING INFORMATION

Ordering Number		Package	Packing
Lead Free Plating	Halogen Free		
3404L-D08-T	3404G-D08-T	DIP-8	Tube
3404L-S08-R	3404G-S08-R	SOP-8	Tape Reel
3404L-P08-R	3404G-P08-R	TSSOP-8	Tape Reel

<p>3404L-D08-R</p> <p>(1) Packing Type (2) Package Type (3) Lead Free</p>	<p>(1) R: Tape Reel, T: Tube (2) D08: DIP-8, P08: TSSOP-8, S08: SOP-8 (3) L: Lead Free Plating, G: Halogen Free</p>
---	---

■ PIN CONFIGURATION

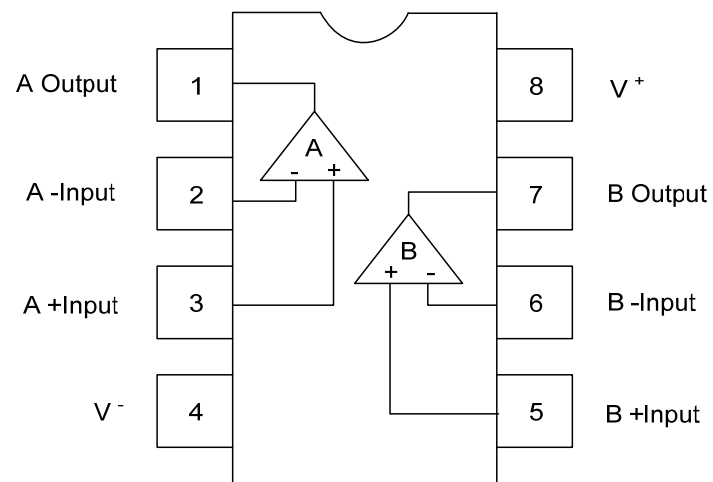

■ EQUIVALENT CIRCUIT (1/2 SHOWN)

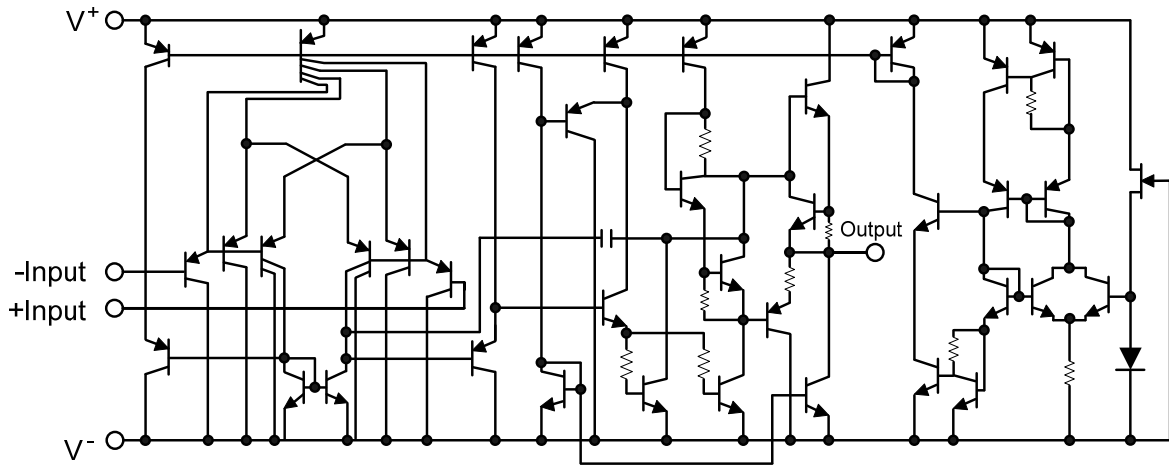

■ ABSOLUTE MAXIMUM RATINGS (T_A=25°C)

PARAMETER		SYMBOL	RATINGS	UNIT
Supply Voltage		V ⁺ (V ⁺ /V)	36V (or±18)	V
Differential Input Voltage		V _{I(DIFF)}	±36	V
Input Voltage		V _{IN}	-0.3 ~ 36	V
Power Dissipation	DIP-8	P _D	500	mW
	SOP-8		300	
	TSSOP8		250	
Ambient Operating Temperature		T _{OPR}	-40 ~+85	°C
Storage Temperature		T _{STG}	-40 ~+125	°C

Note: Absolute maximum ratings are those values beyond which the device could be permanently damaged. Absolute maximum ratings are stress ratings only and functional device operation is not implied.

■ ELECTRICAL CHARACTERISTICS (T_A=25°C, V⁺/V⁻ =±15V)

PARAMETER	SYMBOL	TEST CONDITIONS	MIN	TYP	MAX	UNIT
Input Offset Voltage	V _{I(OFF)}	R _S =0Ω		2	5	mV
Input Offset Current	I _{I(OFF)}			5	50	nA
Input Bias Current	I _{I(BIAS)}			70	200	nA
Large Signal Voltage Gain	G _V	R _L >2KΩ	88	100		dB
Maximum Output Voltage Swing	V _{OM}	R _L =2KΩ	±13	±14		V
Input Common Mode Voltage Range	V _{I(CM)}		-15 ~+13			V
Common Mode Rejection Ratio	CMR	DC	70	90		dB
Supply Voltage Rejection Ratio	SVR		80	94		dB
Operating Current	I _{CC}	R _L =∞		2.0	3.5	mA
Output Source Current	I _{SOURCE}	V _{IN+} =1V, V _{IN-} =0V	20	30		mA
Output Sink Current	I _{O(SINK)}	V _{IN+} =0V, V _{IN-} =1V	10	20		mA
Slew Rate	SR			1.2		V/μs
Unity Gain Bandwidth	f _T			1.2		MHz

■ TYPICAL APPLICATIONS

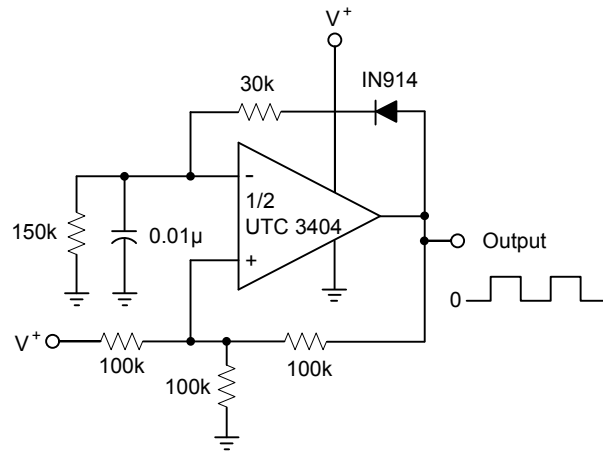

Square Wave Oscillator

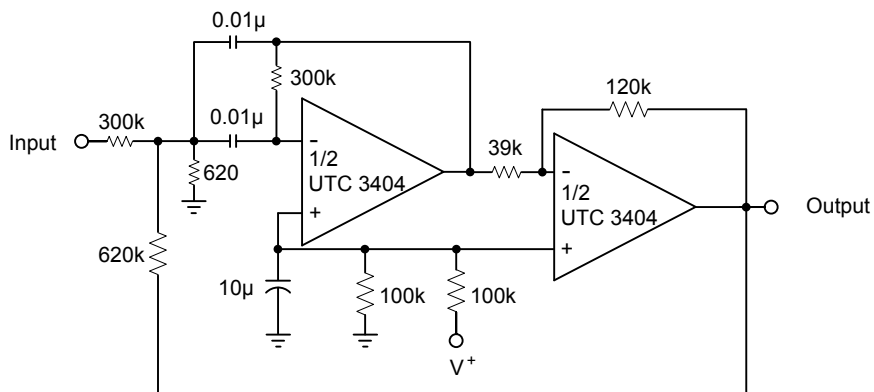

$f_o=1\text{kHz}$

Bandpass Filter

■ TYPICAL CHARACTERISTICS

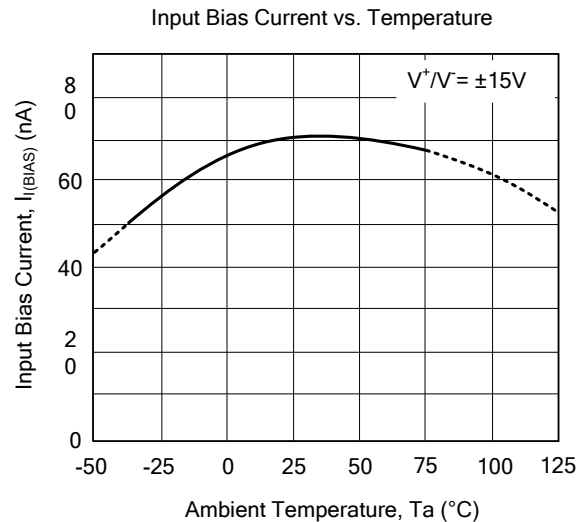
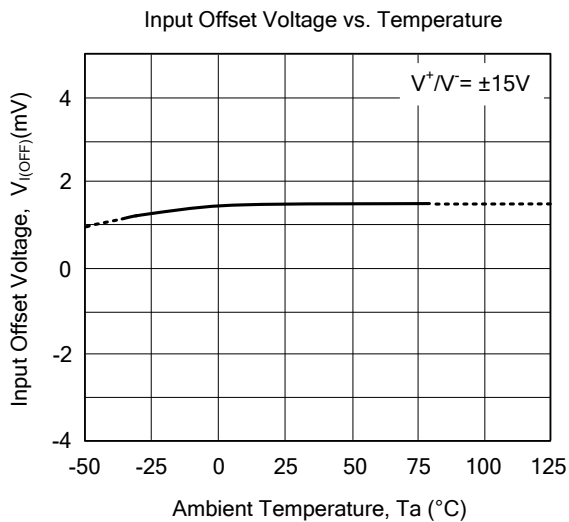
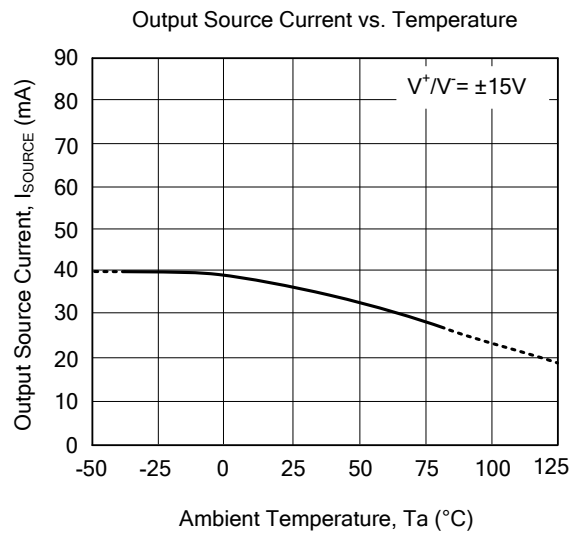
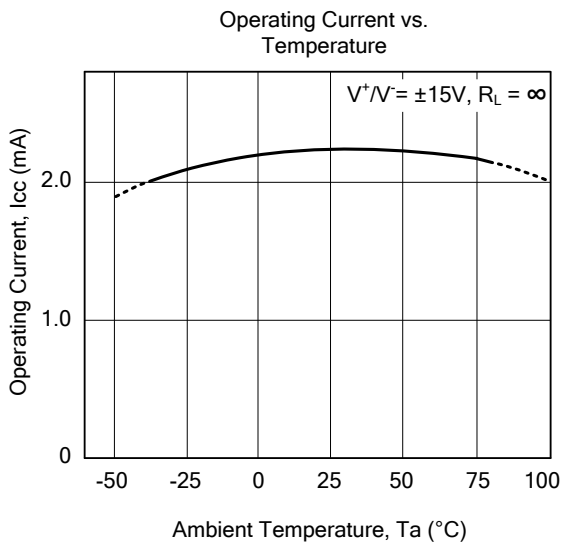
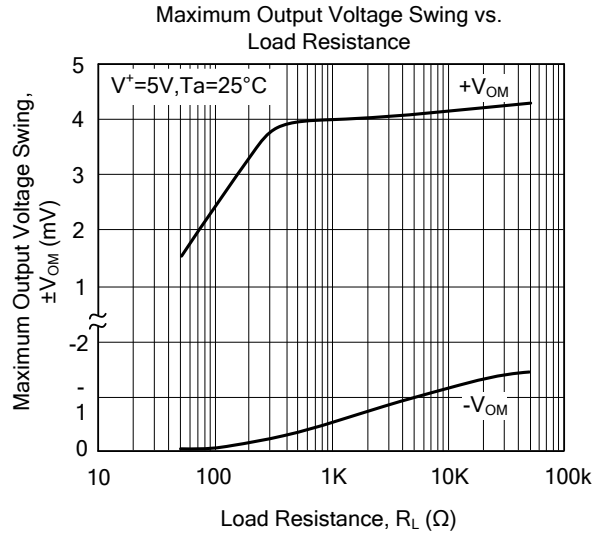
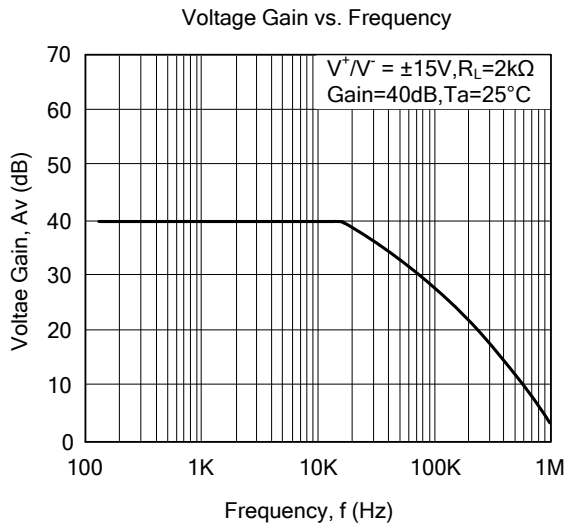

■ TYPICAL CHARACTERISTICS(Cont.)

Output Source Current Output Sink Current vs. Output Voltage Swing

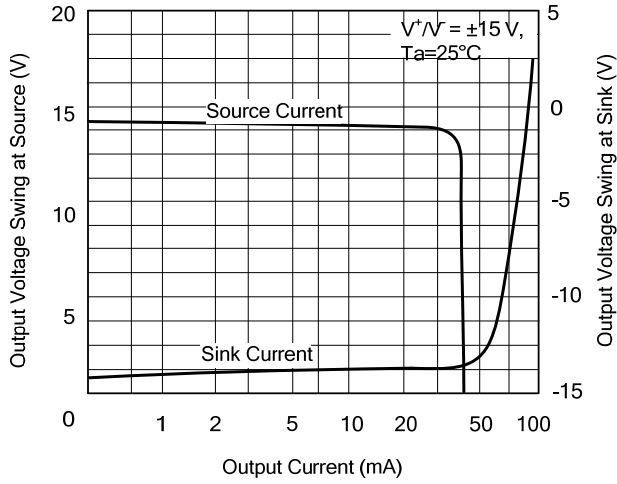

Operating Current vs. Operating Voltage

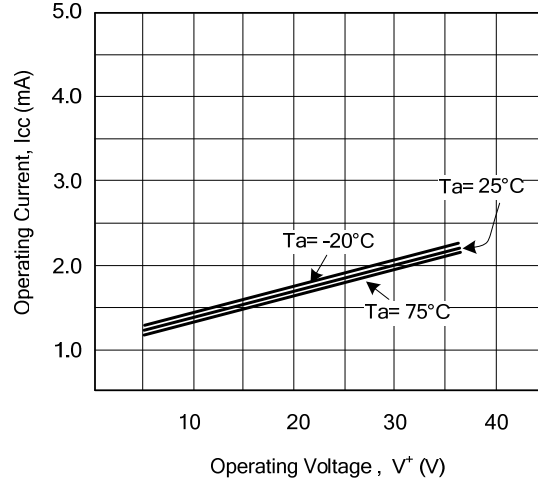

Output Voltage Swing vs. Operating Voltage

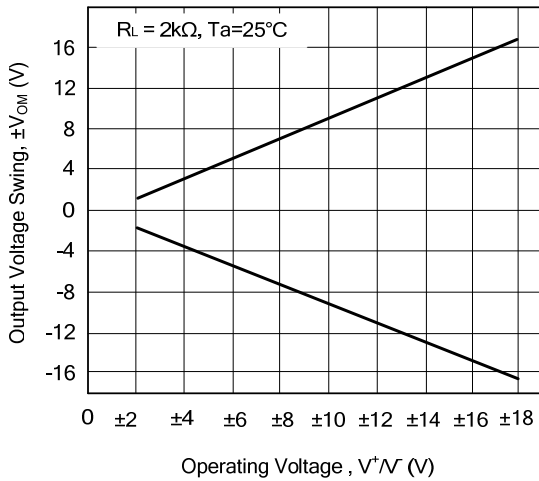

Pulse Response

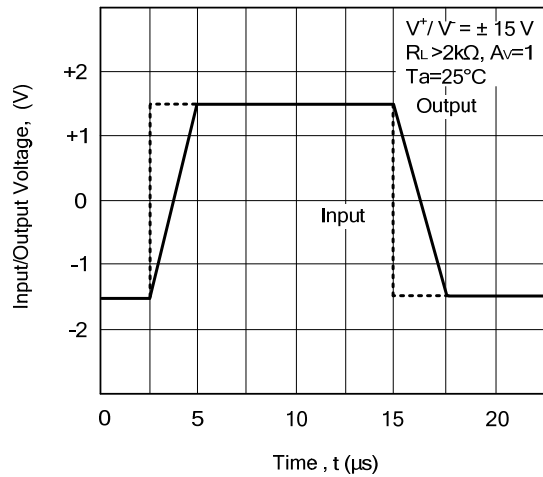

Maximum Output Voltage vs. Frequency

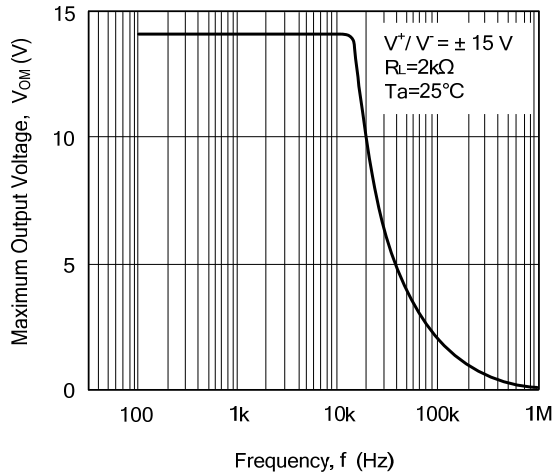

Maximum Output Voltage vs. Temperature

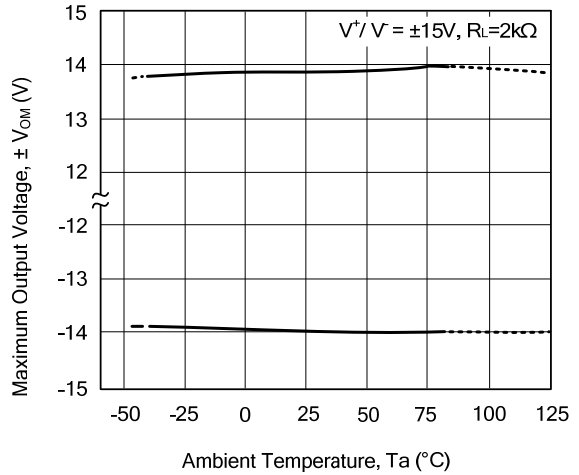

UTC assumes no responsibility for equipment failures that result from using products at values that exceed, even momentarily, rated values (such as maximum ratings, operating condition ranges, or other parameters) listed in products specifications of any and all UTC products described or contained herein. UTC products are not designed for use in life support appliances, devices or systems where malfunction of these products can be reasonably expected to result in personal injury. Reproduction in whole or in part is prohibited without the prior written consent of the copyright owner. The information presented in this document does not form part of any quotation or contract, is believed to be accurate and reliable and may be changed without notice.