



TL084

Preliminary

LINEAR INTEGRATED CIRCUIT

LOW NOISE QUAD J-FET OPERATIONAL AMPLIFIER

DESCRIPTION

The UTC TL084 is a high speed J-FET input quad operational amplifier. It incorporates well matched, high voltage J-FET and bipolar transistors on a monolithic integrated circuit. The device features high slew rates, low input bias and offset current, and low offset voltage temperature coefficient.

FEATURES

- *Low Power Consumption
- *Wide Common-Mode (Up To V_{cc+}) and Differential Voltage Range
- *Low Input Bias and Offset Current
- *Low Noise $eN = 15 \text{ nV}/\sqrt{\text{Hz}}$ (typ)
- *Output Short-Circuit Protection
- *High Input Impedance J-FET Input Stage
- *Low Harmonic Distortion: 0.01%(typ)
- *Internal Frequency Compensation
- *Latch up Free Operation

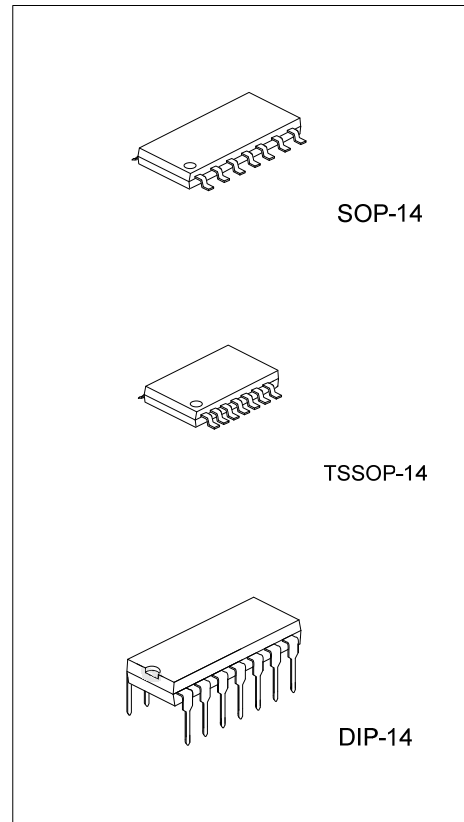

ORDERING INFORMATION

| Ordering Number | | Package | Packing |
|-------------------|--------------|----------|-----------|
| Lead Free Plating | Halogen Free | | |
| TL084L-D14-T | TL084G-D14-T | DIP-14 | Tube |
| TL084L-P14-R | TL084G-P14-R | TSSOP-14 | Tape Reel |
| TL084L-S14-R | TL084G-S14-R | SOP-14 | Tape Reel |

| | |
|---|--|
| <p>TL084L-D14-T</p> <p>(1)Packing Type (2)Package Type (3)Lead Free</p> | <p>(1) T: Tube, R: Tape Reel (2) D14: DIP-14, S14: SOP-14, P14: TSSOP-14 (3) G: Halogen Free, L: Lead Free</p> |
|---|--|

■ PIN CONFIGURATIONS

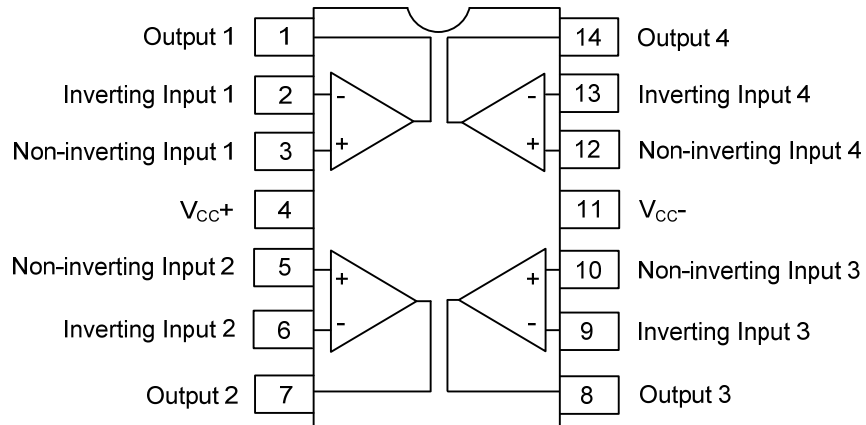

■ SCHEMATIC DIAGRAM

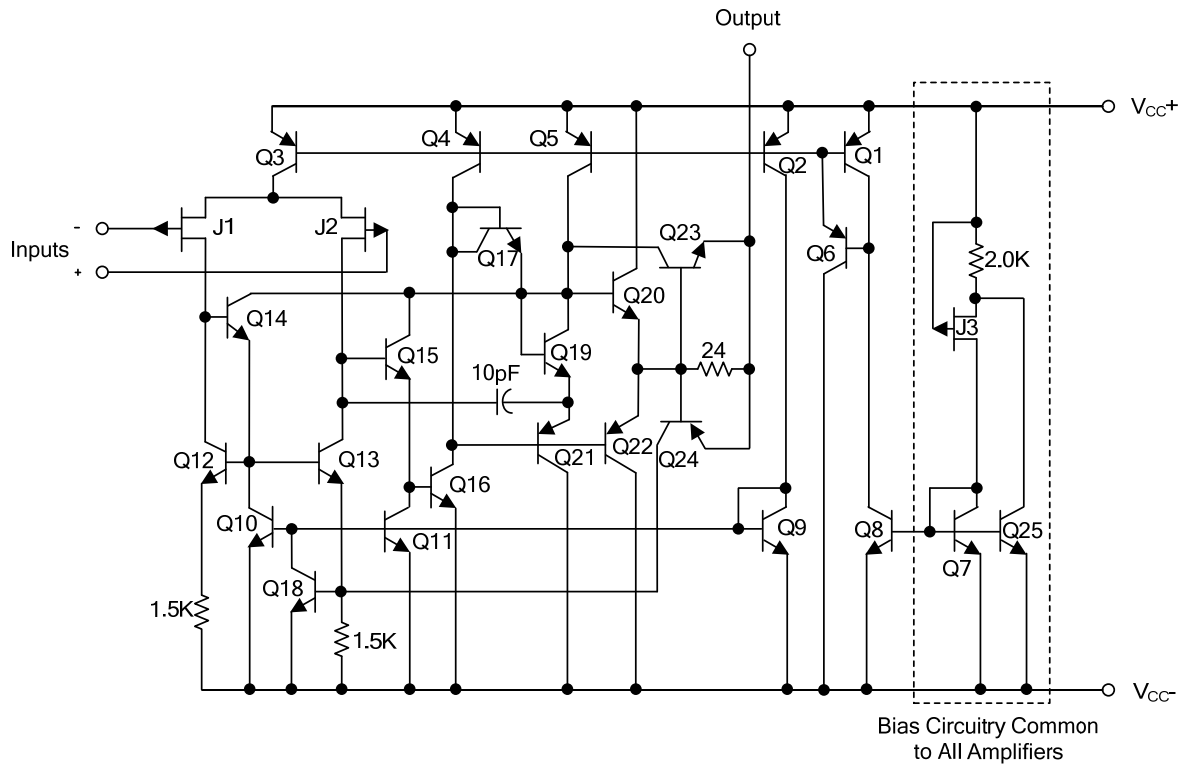

■ **ABSOLUTE MAXIMUM RATINGS** (Ta=25°C)

| PARAMETER | SYMBOL | RATING | UNIT |
|--|----------------------|------------|------|
| Supply Voltage (Note 2) | V _{CC} | ±18 | V |
| Input Voltage (Note 3) | V _{IN} | ±15 | V |
| Differential Input Voltage (Note 4) | V _{I(DIFF)} | ±30 | V |
| Power Dissipation | P _D | 680 | mW |
| Output Short-Circuit Duration (Note 5) | | Infinite | |
| Operating Temperature | T _{OPR} | 0 ~ +70 | °C |
| Storage Temperature | T _{STG} | -65 ~ +150 | °C |

- Notes: 1. Absolute maximum ratings are those values beyond which the device could be permanently damaged. Absolute maximum ratings are stress ratings only and functional device operation is not implied.
2. All voltage values, except differential voltage, are with respect to the zero reference level (ground) of the supply voltages where the zero reference level is the midpoint between V_{CC-} and V_{CC+}.
3. The magnitude of the input voltage must never exceed the magnitude of the supply voltage or 15 volts, whichever is less.
4. Differential voltages are at the non-inverting input terminal with respect to the inverting input terminal.
5. The output may be shorted to ground or to either supply. Temperature and/or supply voltages must be limited to ensure that the dissipation rating is not exceeded.

■ **ELECTRICAL CHARACTERISTICS** (V_{CC}=±15V, T_a=25°C, unless otherwise specified)

| PARAMETER | SYMBOL | TEST CONDITIONS | MIN | TYP | MAX | UNIT |
|---|----------------------|---|-----|------------------|-----|--------|
| Input Offset Voltage | V _{I(OFF)} | R _S ≤ 10kΩ, V _{CM} =0V | | 5 | 15 | mV |
| Temperature Coefficient of Input Offset Voltage | ΔV _{I(OFF)} | R _S =50Ω | | 10 | | μV/°C |
| Input Offset Current (Note) | I _{I(OFF)} | V _{CM} =0V | | 5 | 200 | pA |
| Input Bias Current (Note1) | I _{I(BIAS)} | V _{CM} =0V | | 30 | 400 | pA |
| Input Common Mode Voltage | V _{I(CM)} | | ±10 | -12~+15 | | V |
| Output Voltage Swing | V _{O(SW)} | R _L =10kΩ | 24 | 28 | | V |
| Large Signal Voltage Gain | G _V | R _L ≥ 2kΩ, V _{OUT} =±10V | 25 | 150 | | V/mV |
| Gain Bandwidth Product | GB _W | | | 1 | | MHz |
| Input Resistance | R _{IN} | | | 10 ¹² | | Ω |
| Common Mode Rejection Ratio | CMR | R _S ≤ 10kΩ | 70 | 100 | | dB |
| Supply Voltage Rejection Ratio | SVR | R _S ≤ 10kΩ | 70 | 100 | | dB |
| Supply Current | I _{CC} | No Load | | 1.4 | 2.8 | mA |
| Channel Separation | V01/V02 | G _V =100 | | 120 | | dB |
| Slew Rate | SR | V _{IN} =10V, R _L =2kΩ, C _L =100pF, unity gain | 2.0 | | | V/μs |
| Rise Time | t _R | | | 0.1 | | μs |
| Overshoot Factor | K _{OV} | V _{IN} =20mV, R _L =2kΩ, C _L =100pF, unity gain | | 10 | | % |
| Equivalent Input Noise Voltage | e _N | R _S =100Ω, f=1KHz | | 25 | | nV/√Hz |

Note: The Input bias currents are junction leakage currents, which approximately double for every 10°C increase in the junction temperature.

■ PARAMETER MEASUREMENT INFORMATION

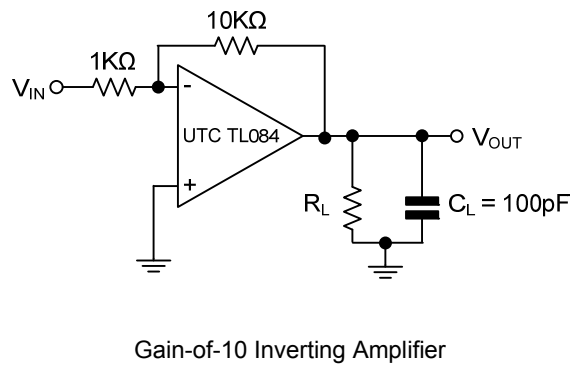
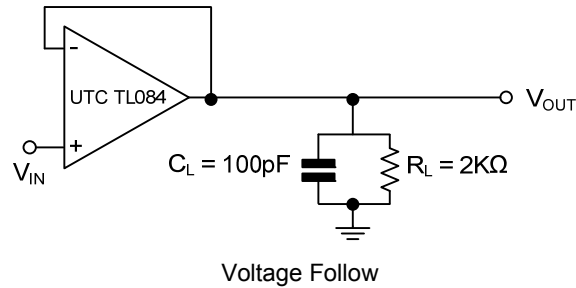

UTC assumes no responsibility for equipment failures that result from using products at values that exceed, even momentarily, rated values (such as maximum ratings, operating condition ranges, or other parameters) listed in products specifications of any and all UTC products described or contained herein. UTC products are not designed for use in life support appliances, devices or systems where malfunction of these products can be reasonably expected to result in personal injury. Reproduction in whole or in part is prohibited without the prior written consent of the copyright owner. The information presented in this document does not form part of any quotation or contract, is believed to be accurate and reliable and may be changed without notice.