



TL082

LINEAR INTEGRATED CIRCUIT

GENERAL PURPOSE DUAL J-FET OPERATIONAL AMPLIFIER

DESCRIPTION

The UTC TL082 is a high speed J-FET input dual operational amplifier. It incorporates well matched, high voltage J-FET and bipolar transistors in a monolithic integrated circuit.

The device features high slew rates, low input bias and offset current, and low offset voltage temperature coefficient.

FEATURES

- * Low input bias and offset current
- * Wide common-mode (up to V_{CC}^+) and differential voltage range
- * Output short-circuit protection
- * High input impedance J-FET input stage
- * Internal frequency compensation
- * Latch up free operation
- * High slewrate: 16V/ μ s(typ.)

ORDERING INFORMATION

Ordering Number			Package	Packing
Normal	Lead Free Plating	Halogen Free		
TL082-D08-T	TL082L-D08-T	TL082G-D08-T	DIP-8	Tube
TL082-P08-R	TL082L-P08-R	TL082G-P08-R	TSSOP-8	Tape Reel
TL082-S08-R	TL082L-S08-R	TL082G-S08-R	SOP-8	Tape Reel

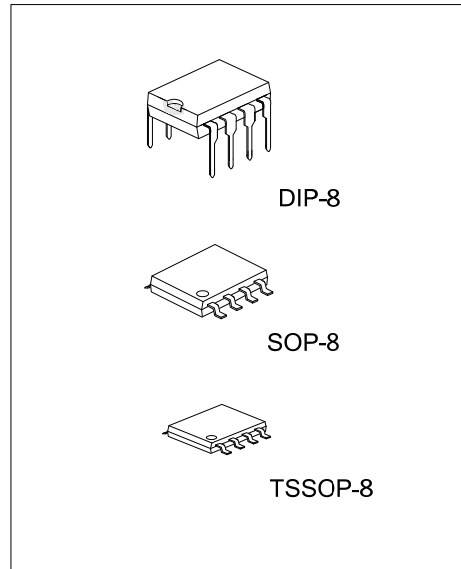

Lead-free: TL082L
 Halogen-free: TL082G

<p>TL082L-D08-T</p> <p>(1) Packing Type</p> <p>(2) Package Type</p> <p>(3) Lead Plating</p>	<p>(1) T: Tube, R: Tape Reel</p> <p>(2) D08: DIP-8, P08: TSSOP-8, S08: SOP-8</p> <p>(3) G: Halogen Free, L: Lead Free, Blank: Pb/Sn</p>
---	---

■ PIN CONFIGURATION

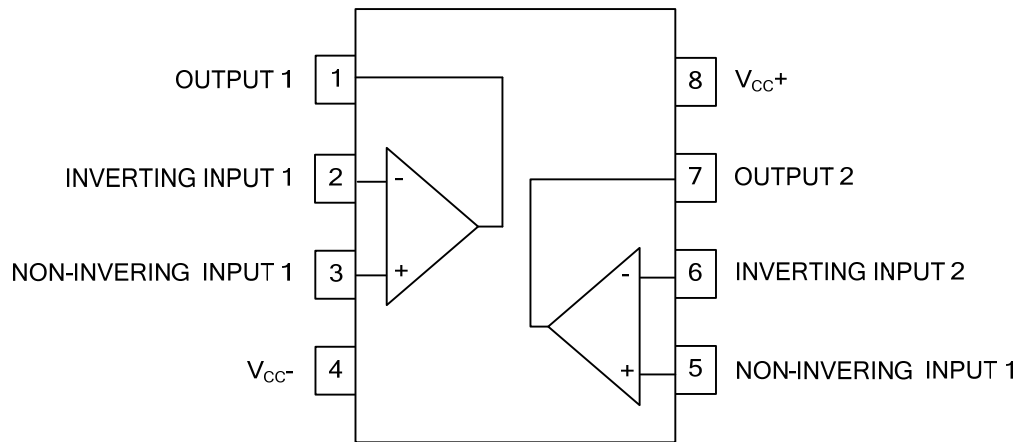

■ BLOCK DIAGRAM

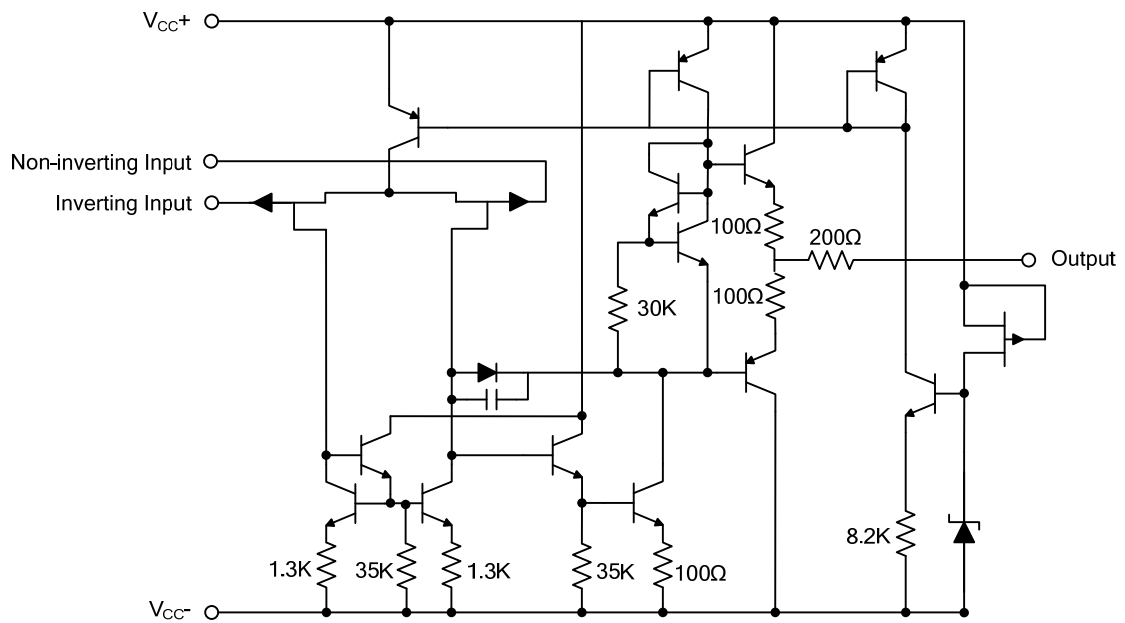

■ ABSOLUTE MAXIMUM RATING (Ta=25°C)

PARAMETER	SYMBOL	RATINGS	UNIT
Supply Voltage (Note 2)	V _{CC}	±18	V
Input Voltage (Note 3)	V _{IN}	±15	V
Differential Input Voltage (Note 4)	V _{ID}	±30	V
Power Dissipation	P _D	680	mW
Output Short-Circuit Duration (Note 5)		Infinite	
Operating Temperature	T _{OPR}	-20 ~ +85	°C
Storage Temperature Range	T _{STG}	-65 ~ +150	°C

- Note: 1. Absolute maximum ratings are those values beyond which the device could be permanently damaged. Absolute maximum ratings are stress ratings only and functional device operation is not implied.
- All voltage values, except differential voltage, are with respect to the zero reference level (ground) of the supply voltages where the zero reference level is the midpoint between V_{CC-} and V_{CC+}.
 - The magnitude of the input voltage must never exceed the magnitude of the supply voltage or 15 volts, whichever is less.
 - Differential voltages are at the non-inverting input terminal with respect to the inverting input terminal.
 - The output may be shorted to ground or to either supply. Temperature and/or supply voltages must be limited to ensure that the dissipation rating is not exceeded.

■ THERMAL DATA

PARAMETER	SYMBOL	RATINGS	UNIT
Junction to Ambient	SOP-8	125	°C/W
	DIP-8	85	°C/W
	TSSOP-8	120	°C/W
Junction to Case	SOP-8	40	°C/W
	DIP-8	41	°C/W
	TSSOP-8	37	°C/W

■ ELECTRICAL CHARACTERISTICS

(V_{CC}=±15V, Ta=25°C, T_{MIN}=0°C, T_{MAX}=70°C, unless otherwise specified)

PARAMETER	SYMBOL	TEST CONDITIONS	MIN	TYP	MAX	UNIT
Input Offset Voltage (R _S =50Ω)	V _{IO}	T _a =25°C		3	10	mV
		T _{MIN} ≤ T _a ≤ T _{MAX}			13	
Input Offset Voltage Drift	D _{VIO}			10		μV/°C
Input Offset Current (Note)	I _{IO}	T _a =25°C		5	100	pA
		T _{MIN} ≤ T _a ≤ T _{MAX}			10	nA
Input Bias Current (Note)	I _{IB}	T _a =25°C		20	400	pA
		T _{MIN} ≤ T _a ≤ T _{MAX}			20	nA
Input Common Mode Voltage Range	V _{ICM}		±11	-12~+15		V
Output Voltage Swing	±V _{OPP}	T _a =25°C, R _L =2kΩ,	10	12		V
		T _a =25°C, R _L =10kΩ	12	13.5		V
		T _{MIN} ≤ T _a ≤ T _{MAX} , R _L =2kΩ	10			V
		T _{MIN} ≤ T _a ≤ T _{MAX} , R _L =10kΩ	12			V
Large Signal Voltage Gain (R _L =2kΩ, V _{OUT} =±10V)	A _{vd}	T _a =25°C	25	200		V/mV
		T _{MIN} ≤ T _a ≤ T _{MAX}	15			
Gain Bandwidth Product (Ta=25°C)	GBP	V _{IN} =10mV, R _L =2kΩ, C _L =100pF, f=100kHz	2.5	4		MHz
Input Resistance	R _i			10 ¹²		Ω
Common Mode Rejection Ratio (R _S =50Ω)	CMR	T _a =25°C	70	86		dB
		T _{MIN} ≤ T _a ≤ T _{MAX}	70			
Supply Voltage Rejection Ratio (R _S =50Ω)	SVR	T _a =25°C	70	86		dB
		T _{MIN} ≤ T _a ≤ T _{MAX}	70			

■ ELECTRICAL CHARACTERISTICS (Cont.)

PARAMETER	SYMBOL	TEST CONDITIONS	MIN	TYP	MAX	UNIT
Supply Current, No Load	I_{CC}	$T_a=25^\circ\text{C}$		3.6	5.6	mA
Channel Separation ($A_v=100$, $T_a=25^\circ\text{C}$)	V_{01}/V_{02}			120		dB
Output Short-Circuit Current	I_{OS}	$T_a=25^\circ\text{C}$	10	40	60	mA
		$T_{MIN} \leq T_a \leq T_{MAX}$	10		60	mA
Slew Rate ($T_a=25^\circ\text{C}$)	SR	$V_{IN}=10\text{V}$, $R_L=2\text{k}\Omega$ $C_L=100\text{pF}$, unity gain	8	16		V/ μs
Rise Time ($T_a=25^\circ\text{C}$)	t_R	$V_{IN}=20\text{mV}$, $R_L=2\text{k}\Omega$ $C_L=100\text{pF}$, unity gain		0.1		μs
Overshoot ($T_a=25^\circ\text{C}$)	K_{OV}	$V_{IN}=20\text{mV}$, $R_L=2\text{k}\Omega$ $C_L=100\text{pF}$, unity gain		10		%
Total Harmonic Distortion ($T_a=25^\circ\text{C}$)	THD	$A_v=20\text{dB}$, $f=1\text{kHz}$, $R_L=2\text{k}\Omega$, $C_L=100\text{pF}$, $V_{OUT}=2\text{Vpp}$)		0.01		%
Phase Margin	Φ_m			45		Degrees
Equivalent Input Noise Voltage ($R_S=100\Omega$, $f=1\text{KHz}$)	eN			15		$\frac{\text{nV}}{\sqrt{\text{Hz}}}$

Note: The Input bias currents are junction leakage currents, which approximately double for every 10°C increase in the junction temperature.

■ PARAMETER MEASUREMENT INFORMATION

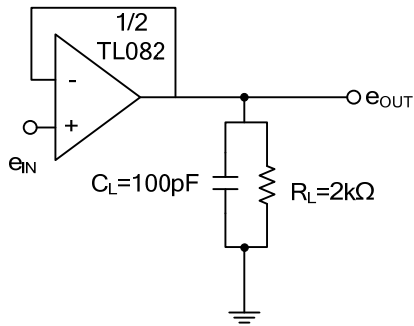

Figure 1. Voltage Follower

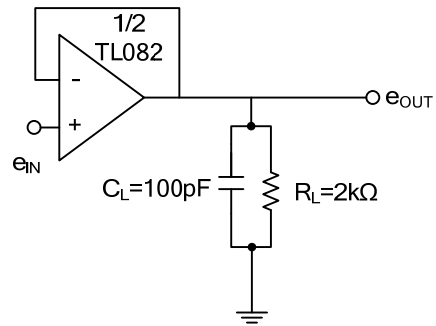
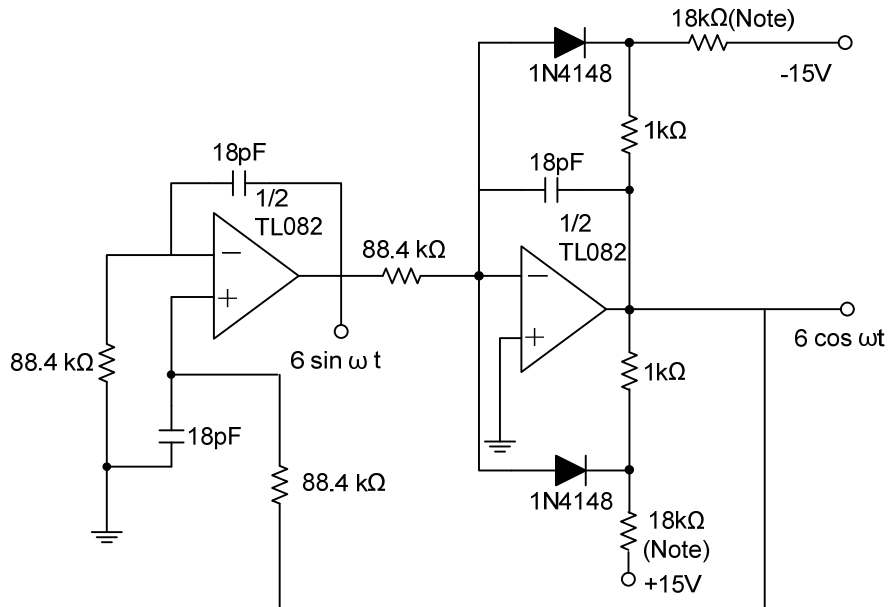

Figure 2. Gain-of-10 Inverting Amplifier

■ TYPICAL APPLICATION CIRCUIT

100 KHz Quadruple Oscillators



Note: These resistors values may be adjusted for a symmetrical output

■ TYPICAL CHARACTERISTICS

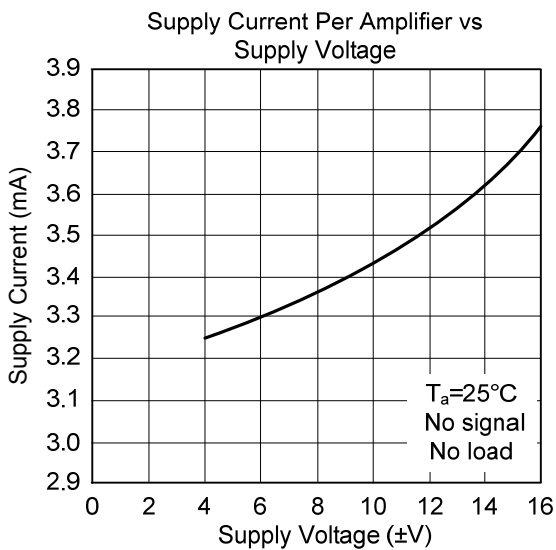
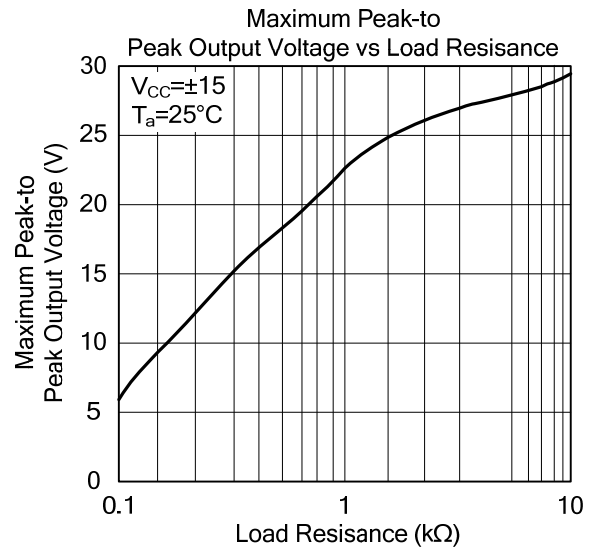
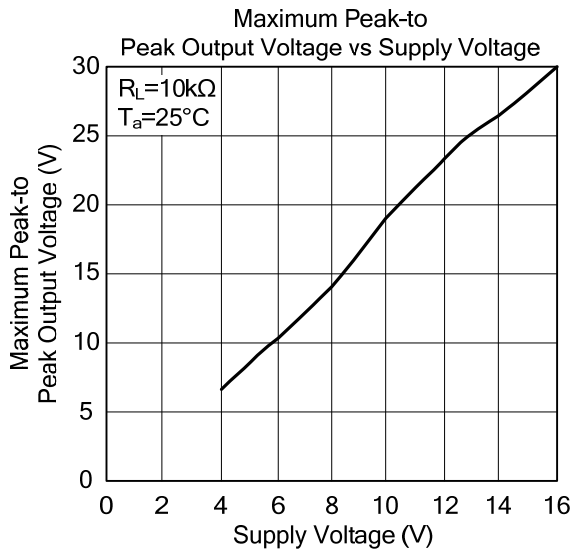
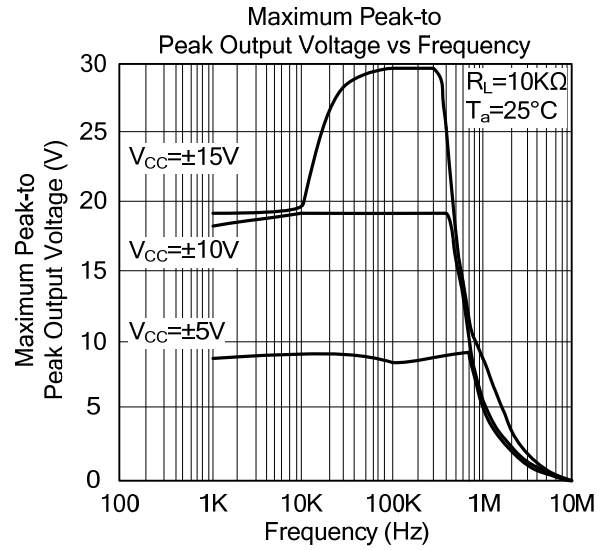
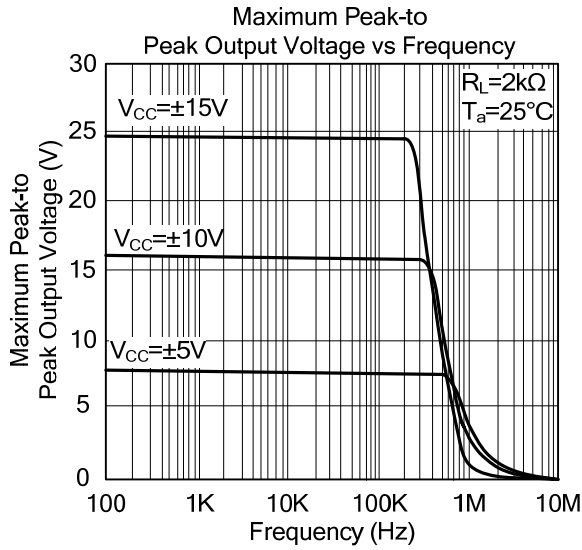

UTC assumes no responsibility for equipment failures that result from using products at values that exceed, even momentarily, rated values (such as maximum ratings, operating condition ranges, or other parameters) listed in products specifications of any and all UTC products described or contained herein. UTC products are not designed for use in life support appliances, devices or systems where malfunction of these products can be reasonably expected to result in personal injury. Reproduction in whole or in part is prohibited without the prior written consent of the copyright owner. The information presented in this document does not form part of any quotation or contract, is believed to be accurate and reliable and may be changed without notice.