

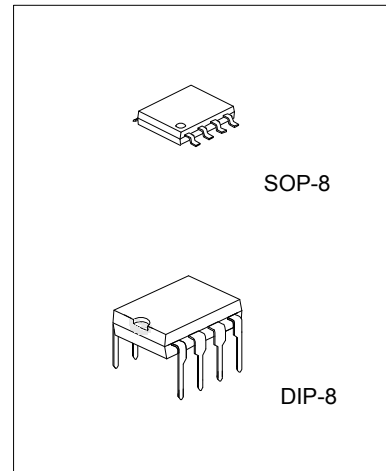

U2429

CMOS IC

SERIAL DATA CONTROL DUAL ELECTRONIC VOLUME



DESCRIPTION

The UTC **U2429** is a dual channel electronic volume controlled with 2-wire serial data.

The built-in reference circuit can compose of an electronic volume with less external parts.

FEATURES

- * Built-in reference circuit
- * Control with serial data Volume 0 ~ -83dB (1dB/step), -∞ (Independent control is allowed in each channel)
- * Low noise and low distortion VNO = 5μVrms (ATT = -∞)
THD = 0.01% Typ. (V0 = 0.5Vrms)

ORDERING INFORMATION

Order Number		Package	Packing
Lead Free	Halogen free		
U2429L-S08-R	U2429G-S08-R	SOP-8	Tape Reel
U2429L-S08-T	U2429G-S08-T	SOP-8	Tube
U2429L-D08-T	U2429G-D08-T	DIP-8	Tube

<p>U2429L-S08-T</p> <p>(1)Packing Type</p> <p>(2)Package Type</p> <p>(3)Lead Plating</p>	<p>(1) T: Tube, R: Tape Reel</p> <p>(2) S08: SOP-8, D08: DIP-8</p> <p>(3) L: Lead Free, G: Halogen free</p>
--	---

■ PIN CONFIGURATION

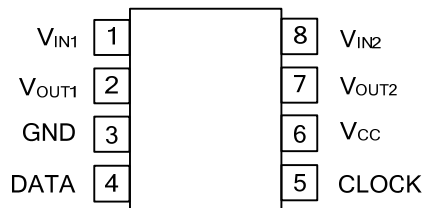

■ PIN DESCRIPTION

PIN NO	PIN NAME	DESCRIPTION
1	V_{IN1}	1-ch input pin
2	V_{OUT1}	1-ch output pin
3	GND	Ground pin
4	DATA	Control data input pin. Inputs data in synchronization with clock.
5	CLOCK	Clock input pin for transferring serial data.
6	V_{CC}	Power supply pin. Stabilize the pin with decoupling capacitor.
7	V_{OUT2}	2-ch output pin
8	V_{IN2}	1-ch input pin

■ BLOCK DIAGRAM

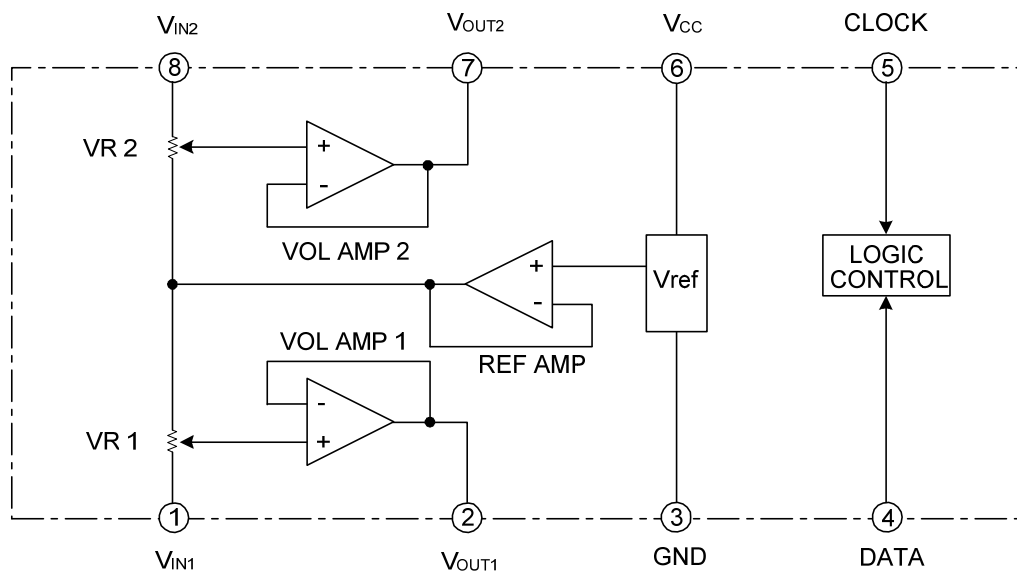

■ ABSOLUTE MAXIMUM RATING

PARAMETER		SYMBOL	RATINGS	UNIT
Supply Voltage		V_{CC}, V_{DD}	6.0	V
Power Dissipation	SOP-8		440	mW
	DIP-8		625	mW
Junction Temperature		T_J	125	°C
Operating Temperature		T_{OPR}	-20 ~ +85	°C
Storage Temperature		T_{STG}	-40 ~ +150	°C

Note: Absolute maximum ratings are those values beyond which the device could be permanently damaged. Absolute maximum ratings are stress ratings only and functional device operation is not implied.

■ RECOMMENDED OPERATING CONDITIONS

PARAMETER		SYMBOL	RATINGS	UNIT
Supply voltage range		V_{CC}	4.5 ~ 5.5	V
Rated supply voltage		V_{CC}	5	V

■ ELECTRICAL CHARACTERISTICS ($V_{CC} = 5V, T_A = 25^\circ C$, unless otherwise noted)

PARAMETER	SYMBOL	TEST CONDITIONS	MIN	TYP	MAX	UNIT
Circuit current	I_{CC}			8	16	mA
Maximum attenuation	A_{TT}	$A_{TT} = -\infty$		-90	-80	dB
Attenuation error	A_{TT}	$A_{TT} = 0$	-2.0	0	2.0	dB
Maximum input voltage	V_{IM}	THD=1%, $A_{TT} = -6dB$	1.5	1.7		V _{rms}
Maximum output voltage	V_{OM}	THD=1%	0.8	1.3		V _{rms}
Output noise voltage	V_{NO1}	$A_{TT} = 0, R_g = 0$		4	10	μV _{rms}
	V_{NO2}	$A_{TT} = -\infty, R_g = 0$		5	10	μV _{rms}
Total harmonic distortion	THD	$f = 1kHz, V_o = 0.5V_{rms}, A_{TT} = 0$		0.01	0.05	%
Channel separation	CS	$f = 1kHz$		-80	-70	dB

■ DC CHARACTERISTICS OF DIGITAL BLOCK

PARAMETER	SYMBOL	TEST CONDITIONS	MIN	TYP	MAX	UNIT
"L" level input voltage	V_{IL}	Data, clock pin	0		$0.2V_{CC}$	V
"H" level input voltage	V_{IH}		$0.8V_{CC}$		V_{CC}	V
"L" level input current	I_{IL}	$V_i = 0$	-10		10	μA
"H" level input current	I_{IH}	$V_i = 5V$			10	μA

■ AC CHARACTERISTICS OF DIGITAL BLOCK

PARAMETER	SYMBOL	TEST CONDITIONS	MIN	TYP	MAX	UNIT
Cycle time of clock	t_{cr}	$V_{DD} = 5V$	4			μs
Pulse width of clock ("H" level)	t_{WHC}	$V_{DD} = 5V$	1.6			μs
Pulse width of clock ("L" level)	t_{WLC}	$V_{DD} = 5V$	1.6			μs
Clock rising time	t_r	$V_{DD} = 5V$			0.4	μs
Clock falling time	t_f	$V_{DD} = 5V$			0.4	μs
Data setup time	t_{SD}	$V_{DD} = 5V$	0.8			μs
Data hold time	t_{HD}	$V_{DD} = 5V$	0.8			μs

Note: UTC products on power start, DATA conversion or IC first start are all without delay time. When DATA reading is completed, the output immediately respond.

■ RELATIONSHIP BETWEEN DATA AND CLOCK

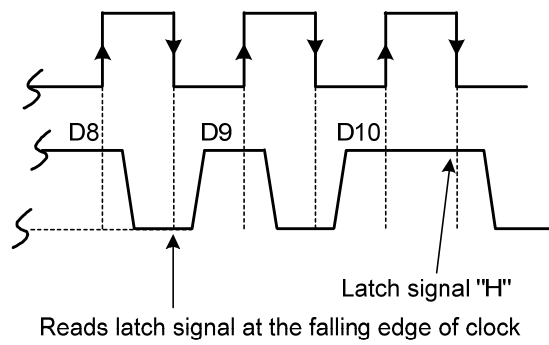
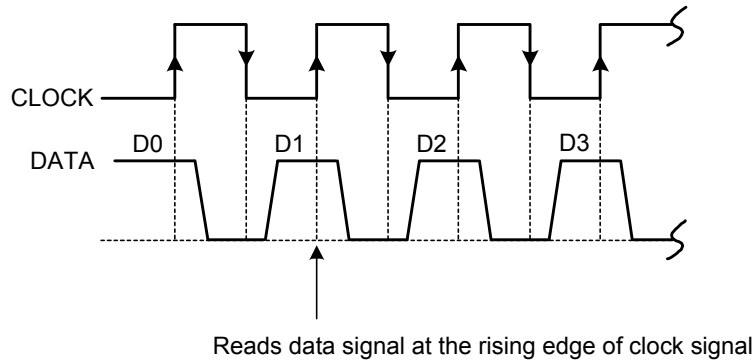

■ SYSTEM CONFIGURATION

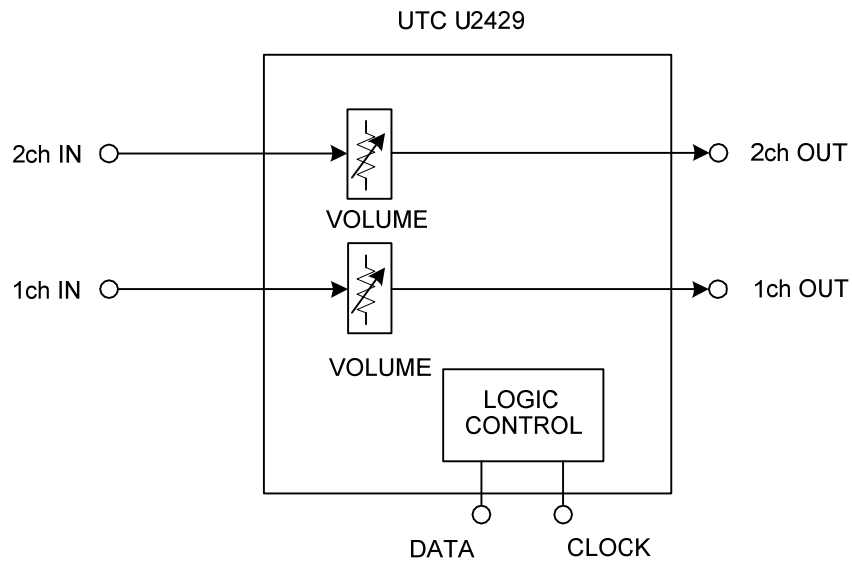

■ CLOCK AND DATA TIMING

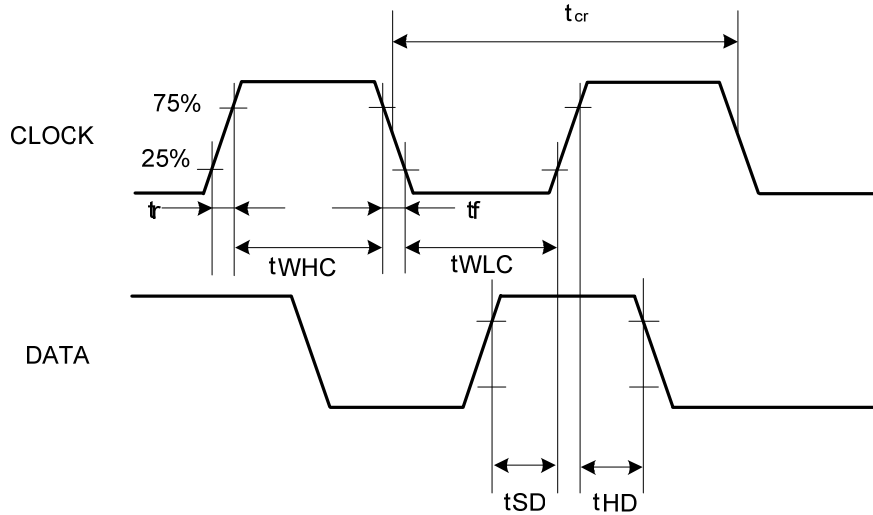

■ DATA INPUT FORMAT

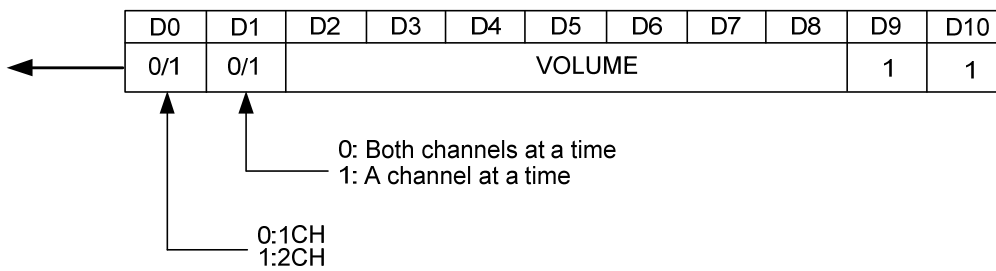

■ VOLUME CODE

ATT1	D2	D3	D4	D5	D6
0dB	H	L	H	L	H
-4dB	L	L	H	L	H
-8dB	H	H	L	L	H
-12dB	L	H	L	L	H
-16dB	H	L	L	L	H
-20dB	L	L	L	L	H
-24dB	H	H	H	H	L
-28dB	L	H	H	H	L
-32dB	H	L	H	H	L
-36dB	L	L	H	H	L
-40dB	H	H	L	H	L
-44dB	L	H	L	H	L
-48dB	H	L	L	H	L
-52dB	L	L	L	H	L
-56dB	H	H	H	L	L
-60dB	L	H	H	L	L
-64dB	H	L	H	L	L
-68dB	L	L	H	L	L
-72dB	H	H	L	L	L
-76dB	L	H	L	L	L
-80dB	H	L	L	L	L
	L	L	L	L	L

ATT2	D7	D8
0dB	H	H
-1dB	L	H
-2dB	H	L
-3dB	L	L

UTC assumes no responsibility for equipment failures that result from using products at values that exceed, even momentarily, rated values (such as maximum ratings, operating condition ranges, or other parameters) listed in products specifications of any and all UTC products described or contained herein. UTC products are not designed for use in life support appliances, devices or systems where malfunction of these products can be reasonably expected to result in personal injury. Reproduction in whole or in part is prohibited without the prior written consent of the copyright owner. The information presented in this document does not form part of any quotation or contract, is believed to be accurate and reliable and may be changed without notice.