



TDA8496

LINEAR INTEGRATED CIRCUIT

5W+5W AMPLIFIER WITH DC VOLUME CONTROL

DESCRIPTION

The UTC **TDA8496** is a stereo 5+5W class AB power amplifier with mute and dc volume control, assembled in the HZIP-15A/B/D package. It is designed for high quality sound, LCD TV or LCD Monitor applications.

FEATURES

- * 5+5w output power @ $V_{CC}= 22V$; $R_L = 8\Omega$
- * Low turn-on turn-off pop noise
- * Low external components
- * Short circuit & thermal overload protection
- * Linear volume control by DC voltage
- * Soft clipping
- * Internally fixed gain
- * St-by and mute functions

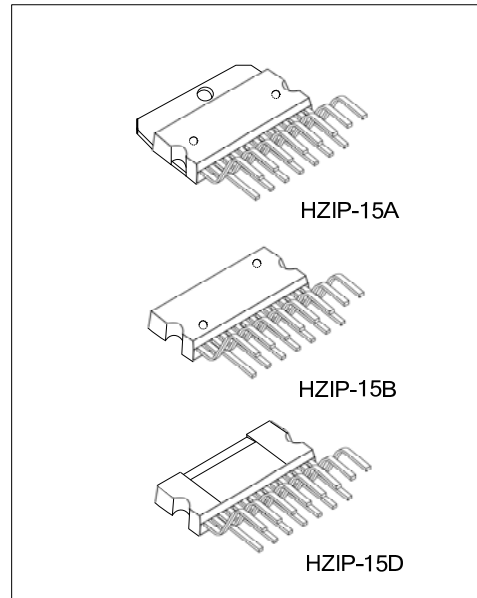

ORDERING INFORMATION

Ordering Number			Package	Packing
Normal	Lead Free	Halogen Free		
TDA8496-J15-A-T	TDA8496L-J15-A-T	TDA8496G-J15-A-T	HZIP-15A	Tube
TDA8496-J15-B-T	TDA8496L-J15-B-T	TDA8496G-J15-B-T	HZIP-15B	Tube
TDA8496-J15-D-T	TDA8496L-J15-D-T	TDA8496G-J15-D-T	HZIP-15D	Tube

<p>TDA8496L-J15-A-T</p> <p>(1) Packing Type (2) Package Type (3) Lead Free</p>	<p>(1) T: Tube (2) J15-A:HZIP-15A, J15-B:HZIP-15B, J15-D:HZIP-15D (3) G: Halogen Free, L: Lead Free, Blank: Pb/Sn</p>
--	---

PIN DESCRIPTION (TOP VIEW)

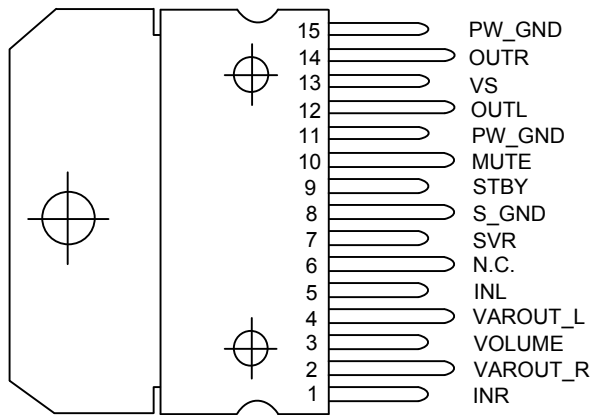

HZIP-15A

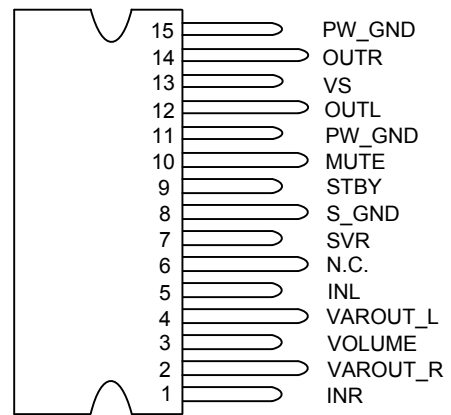

HZIP-15B/HZIP-15D

BLOCK DIAGRAM

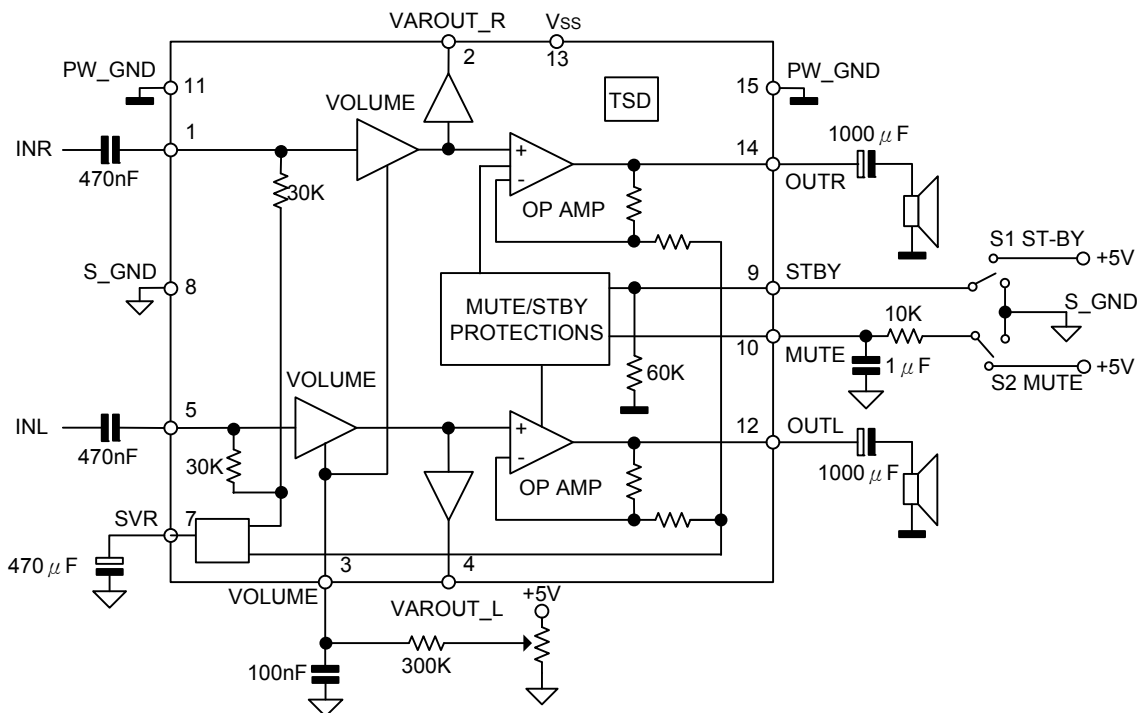

■ ABSOLUTE MAXIMUM RATINGS

PARAMETER		SYMBOL	RATINGS	UNIT
DC Supply voltage		V_{SS}	35	V
Maximum Input Voltage		$V_{IN(MAX)}$	8	V_{PP}
Volume Control DC Voltage		V_3	7	V
Power Dissipation ($T_A=80^{\circ}C$)	HZIP-15A/HZIP-15B	P_D	15	W
	HZIP-15D		12.5	
Junction Temperature		T_J	+150	$^{\circ}C$
Ambient Operating Temperature		T_{OPR}	0 ~ +70	$^{\circ}C$
Storage Temperature		T_{STG}	-40 ~ +150	$^{\circ}C$

Note: Absolute maximum ratings are those values beyond which the device could be permanently damaged.

Absolute maximum ratings are stress ratings only and functional device operation is not implied.

■ THERMAL DATA

PARAMETER		SYMBOL	RATINGS	UNIT
Junction to Ambient	HZIP-15A/HZIP-15B	θ_{JA}	35	$^{\circ}C/W$
	HZIP-15D		46	
Junction to Case	HZIP-15A/HZIP-15B	θ_{JC}	4.6	$^{\circ}C/W$
	HZIP-15D		5.0	

■ ELECTRICAL CHARACTERISTICS (refer to the test circuit $V_{SS}=22V$, $R_L=8\Omega$, $R_G=50\Omega$, $T_A=25^{\circ}C$)

PARAMETER	SYMBOL	TEST CONDITIONS	MIN	TYP	MAX	UNIT
Supply Voltage Range	V_{SS}		10		32	V
Output DC Offset Referred to SVR Potential	$V_{OUT(OFF)}$	No Input Signal		200		mV
Quiescent Output Voltage	$V_{Q(OUT)}$			11		V
Output Power	P_{OUT}	THD = 10%, $R_L = 8\Omega$	5	5.5		W
		THD = 1%, $R_L = 8\Omega$		4		
		THD = 10%, $R_L = 4\Omega$, $V_{SS} = 12V$		2.1		W
		THD = 1%, $R_L = 4\Omega$, $V_{SS} = 12V$		1.0		
Total Harmonic Distortion	THD	$G_V = 30dB$, $P_{OUT} = 1W$, $f = 1KHz$			0.4	%
Total Quiescent Current	I_Q			25	50	mA
Output Peak Current	I_{PEAK}	(internally limited)	1.0	1.3		A
Input Signal	V_{IN}				2.8	Vrms
Closed Loop Gain	G_V	$V_{O(L CTRL)} > 4.5V$	28.5	30	31.5	dB
Monitor Out Gain	$G_{V(LINE)}$	$V_{O(L CTRL)} > 4.5V$, $Z_{LOAD} > 30K\Omega$	-1.5	0	1.5	dB
Attenuation at Minimum Volume	A_{MIN}	$V_{O(L CTRL)} < 0.5V$	80			dB
Bandwidth	BW			0.6		MHz
Total Output Noise	e_N	$f = 20Hz \sim 22KHz$	PLAY, Max volume	500	800	μV
			PLAY, Max attenuation	100	250	μV
			Mute	60	150	μV
Slew Rate	SR		5	8		V/ μs
Input Resistance	R_{IN}		22.5	30		K Ω
Variable Output Resistance	$R_{VAR(OUT)}$			30	100	Ω
Variable Output Load	$R_{L(OUT)}$		2			K Ω
Supply Voltage Rejection	SVR	$f=1KHz$, $C_{SVR}=470mF$, $V_{RIP}=1V_{rms}$	Max volume	35	39	dB
			Max attenuation	55	65	dB
Thermal Muting	T_{MUTE}			150		$^{\circ}C$
Thermal Shut-down	T_{SHDN}			160		$^{\circ}C$

■ ELECTRICAL CHARACTERISTICS(Cont.)

PARAMETER	SYMBOL	TEST CONDITIONS	MIN	TYP	MAX	UNIT
MUTE STAND-BY & INPUT SELECTION FUNCTIONS						
Stand-by ON Threshold	$V_{THD(SON)}$		3.5			V
Stand-by OFF Threshold	$V_{THD(SOFF)}$				1.5	V
Mute ON threshold	$V_{THD(MON)}$		3.5			V
Mute OFF threshold	$V_{THD(MOFF)}$				1.5	V
Mute Attenuation	A_{MUTE}		50	65		dB
Quiescent Current @ Stand-by	$I_{Q(ST-BY)}$			0.6	1	mA
Stand-by Bias Current	$I_{ST-BY(BIAS)}$	Stand by ON: $V_{ST-BY} = 5V, V_{MUTE} = 5V$		80		μA
		Play or Mute	-20	-5		μA
Mute Bias Current	$I_{MUTE(BIAS)}$	Mute		1	5	μA

■ TYPICAL APPLICATION CIRCUIT

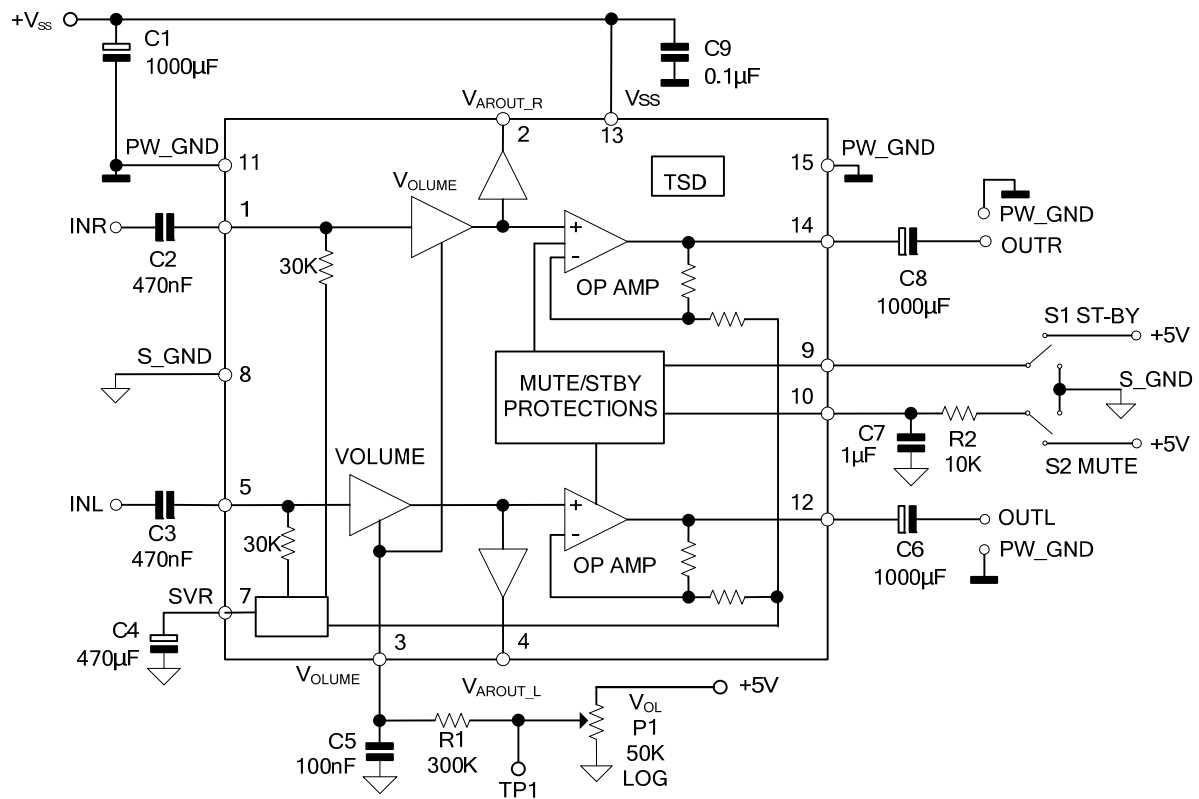

Fig. 1 Application Circuit

MUTE STAND-BY TRUTH TABLE

MUTE	STAND-BY	OPERATING CONDITION
H	H	STAND-BY
L	H	STAND-BY
H	L	MUTE
L	L	PLAY

■ TYPICAL APPLICATION CIRCUIT(Cont.)

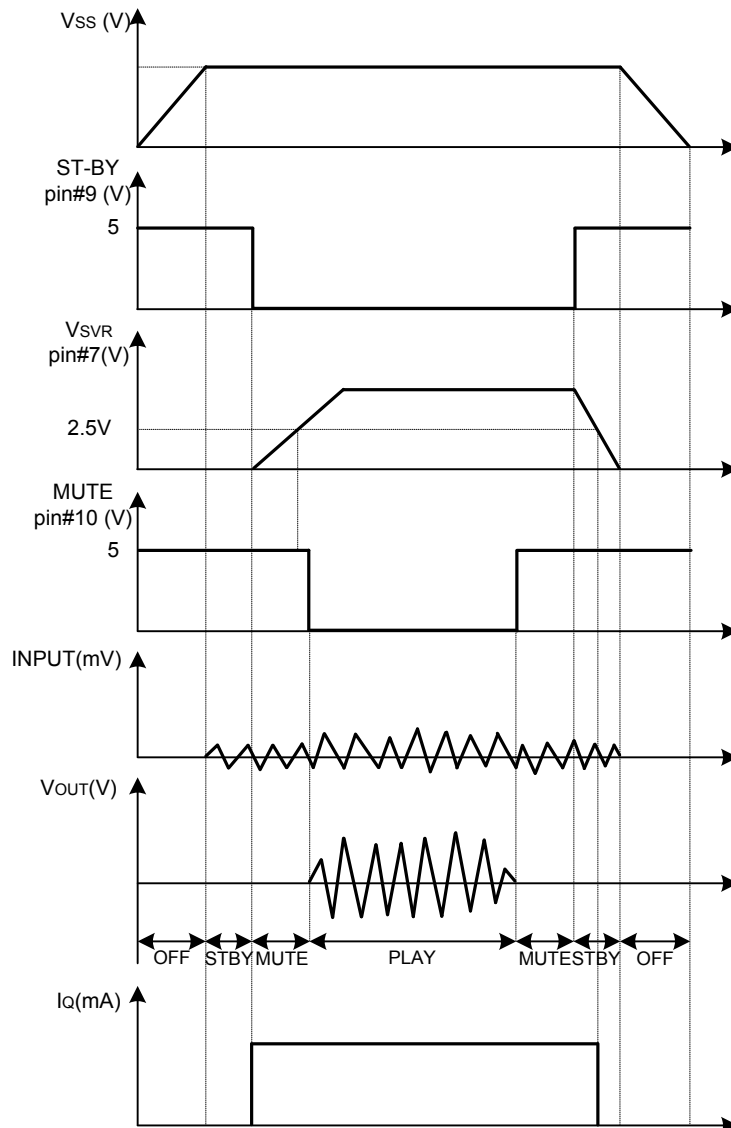
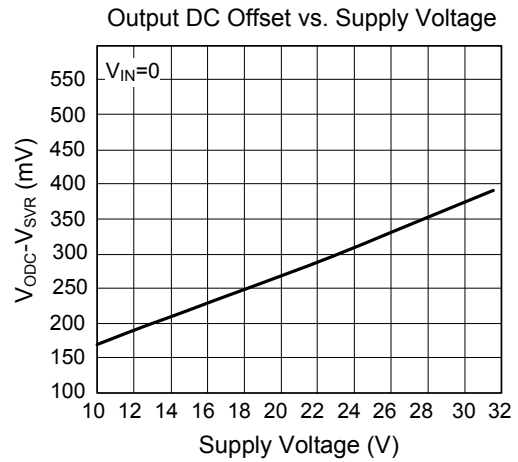
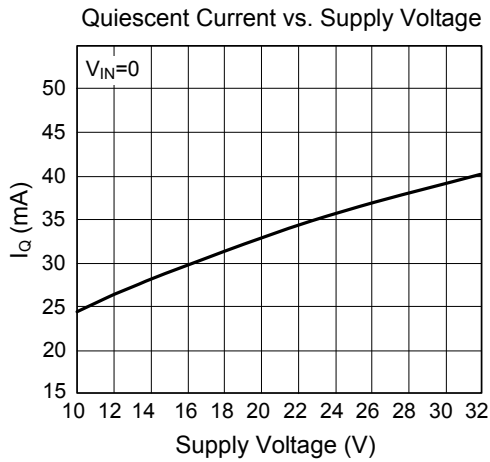
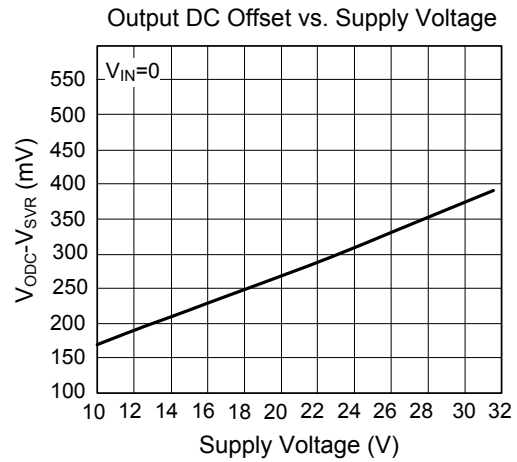
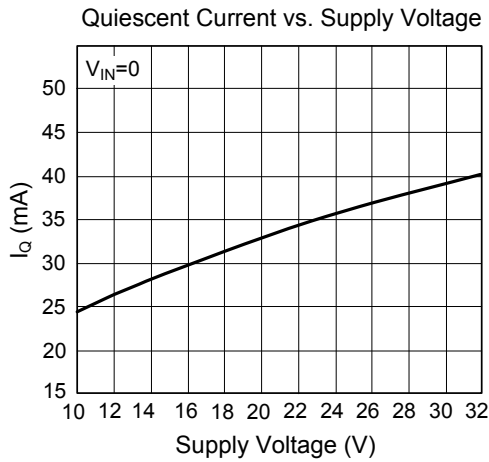

Fig. 2 Turn ON/OFF Sequences (use only the MUTE function)

■ TYPICAL CHARACTERISTICS



UTC assumes no responsibility for equipment failures that result from using products at values that exceed, even momentarily, rated values (such as maximum ratings, operating condition ranges, or other parameters) listed in products specifications of any and all UTC products described or contained herein. UTC products are not designed for use in life support appliances, devices or systems where malfunction of these products can be reasonably expected to result in personal injury. Reproduction in whole or in part is prohibited without the prior written consent of the copyright owner. The information presented in this document does not form part of any quotation or contract, is believed to be accurate and reliable and may be changed without notice.