



PA7468

Preliminary

CMOS IC

STEREO 2.6W AUDIO POWER AMPLIFIER WITH DC VOLUME CONTROL

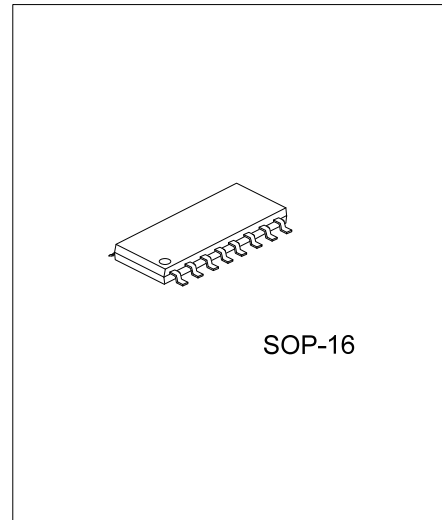

DESCRIPTION

As an audio power amplifier with DC volume control, UTC PA7468 is a stereo bridged audio power amplifier. In normal operation it can produce 2.6W (1.8W) into 4Ω with less than 10% (1.0%) THD+N.

In UTC PA7468, the attenuator range of the volume control is from 20dB (@DC_V_{OL}=0V) to -80dB (@DC_V_{OL}=3.54V) with 32 steps. Besides, the UTC PA7468 includes the depop circuitry and the thermal shutdown protection circuitry (to reduce pops and clicks noise during power up or shutdown mode operation).

The UTC PA7468 has a BTL mode for speaker drive and a SE mode for headphone drive. These tow modes can be quickly chosen by the SE/BTL input control pin signal.

FEATURES

- * Low Operating Current: 9mA
- * Two Output Modes Allowable with BTL and SE Modes(chosen by SE/BTL pin)
- * Low Current Consumption :1mA(in Shutdown Mode)
- * With Short Circuit Protection
- * With Thermal Shutdown Protection
- * With Over Current Protection Circuitry
- * Eliminating Turn-on and Turn-off Transients in Outputs by Improved Depop Circuitry to.
- * Very High PSRR
- * 32 Steps Volume Adjustable
- * BTL Mode :2.6W per Channel Output Power into 4Ω Load at 5V

ORDERING INFORMATION

Ordering Number		Package	Packing
Lead Free	Halogen Free		
PA7468L-S16-R	PA7468G-S16-R	SOP-16	Tape Reel
PA7468L-S16-T	PA7468G-S16-T	SOP-16	Tube

<p>PA7468L-S16-R</p>	<p>(1) Packing Type</p> <p>(2) Package Type</p> <p>(3) Lead Free</p>	<p>(1) R: Tape Reel</p> <p>(2) S16: SOP-16</p> <p>(3) G: Halogen Free, L: Lead Free</p>
----------------------	--	---

■ PIN CONFIGURATION

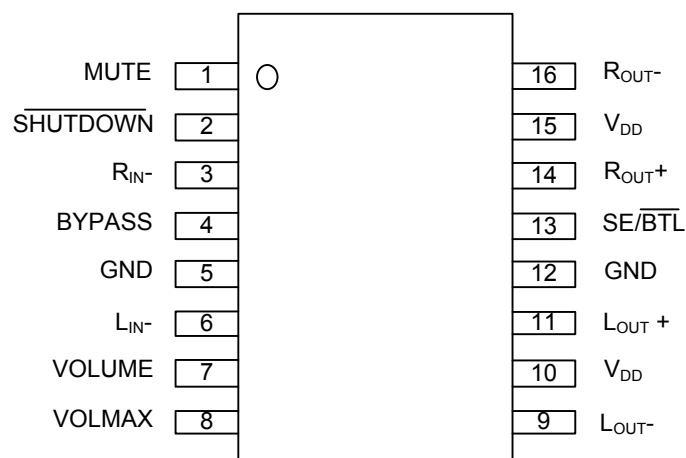

■ PIN DESCRIPTION

PIN NO.	PIN NAME	DESCRIPTION
1	MUTE	Input pin for mute controlling: low for normal operation; high to mute.
2	SHUTDOWN	When this pin is pulled low the chip will be into shutdown mode. $I_{SD} = 1\mu A$
3	R _{IN-}	Right channel input pin
4	BYPASS	Pin for bias voltage generator
5,12	GND	Ground
6	L _{IN-}	Left channel input pin
7	VOLUME	Volume gain setting input signal.
8	VOLMAX	Pin for setting the maximum output swing. Inputting V_C to this pin, the output voltage swing will be clamped between $V_{OH} - V_C$ & $V_{OL} + V_C$. Connecting GND to this pin will disable the function. For this pin, the max input voltage must be $\leq 1/2 V_{DD}$.
9	L _{OUT-}	Left channel's negative output in BTL mode; high impedance in SE mode.
10, 15	V _{DD}	Supply voltage
11	L _{OUT+}	Left channel's positive output in BTL mode and SE mode
13	SE/BTL	Output mode control input, high :SE output mode ,low :for BTL mode.
14	R _{OUT+}	Right channel's positive output in BTL mode and SE mode
16	R _{OUT-}	Right channel's negative output in BTL mode ;high impedance in SE mode.

■ BLOCK DIAGRAM

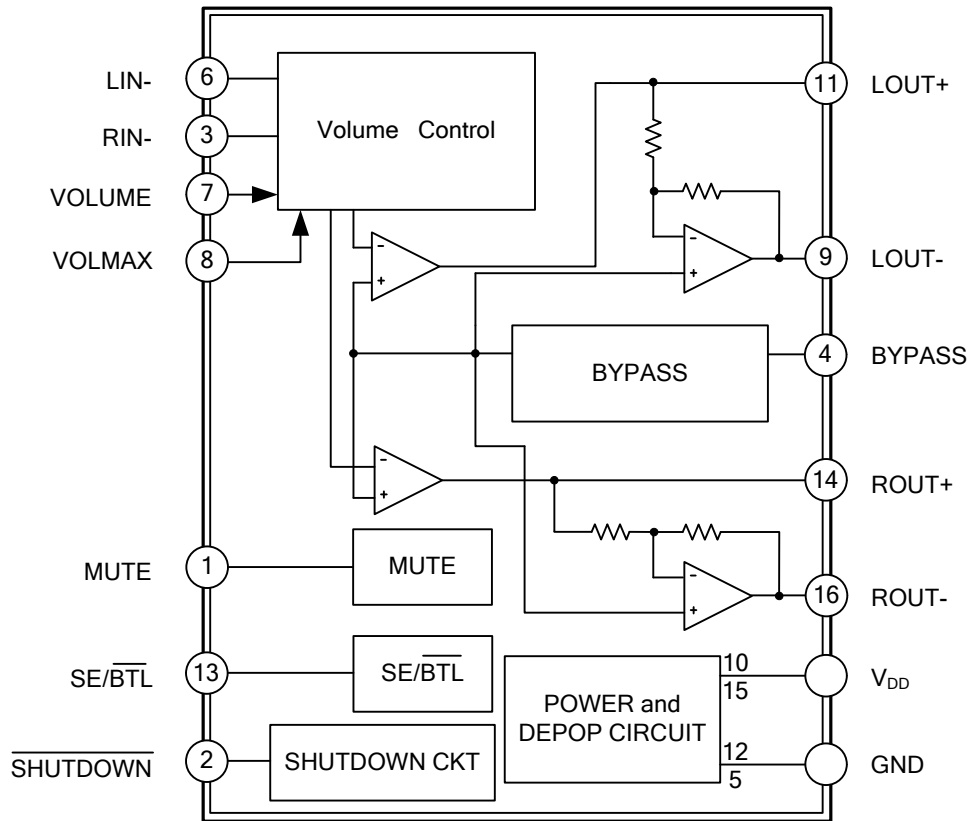

■ ABSOLUTE MAXIMUM RATING (unless otherwise specified)

PARAMETER	SYMBOL	RATINGS	UNIT
Supply Voltage	V_{DD}	-0.3 ~ +6.0	V
Input Voltage (SE/BTL, SHUTDOWN, MUTE)	V_{IN}	-0.3 ~ $V_{DD}+0.3$	V
Power Dissipation	P_D	Internal Limited	W
Junction Temperature	T_J	150	°C
Storage Temperature	T_{STG}	-65 ~ +150	°C

Note: Absolute maximum ratings are those values beyond which the device could be permanently damaged.
Absolute maximum ratings are stress ratings only and functional device operation is not implied.

■ THERMAL DATA

PARAMETER	SYMBOL	RATINGS	UNIT
Junction to Ambient	θ_{JA}	90	°C/W

■ RECOMMENDED OPERATING CONDITIONS

PARAMETER	SYMBOL	RATINGS	UNIT		
Supply Voltage	V_{DD}	4.5 ~ 5.5	V		
Threshold Voltage	High	SHUTDOWN, MUTE	V_{IH}	2.0	V
		SE/BTL		4.0	V
	Low	SHUTDOWN, MUTE	V_{IL}	1.0	V
		SE/BTL		1.0	V
Common Mode Input Voltage	V_{ICM}	$V_{DD}-1.0$	V		
Ambient Temperature	T_A	-40 ~ 85	°C		

■ ELECTRICAL CHARACTERISTICS ($T_A=25^\circ\text{C}$, unless otherwise specified)

$V_{DD} = 5\text{V}$

PARAMETER	SYMBOL	TEST CONDITIONS	MIN	TYP	MAX	UNIT
Output Differential Voltage	V_{OS}			5		mV
Supply Current	I_{DD}	SE/BTL = 0V		9	20	mA
		SE/BTL = 5V		4	10	mA
Supply Current in Shutdown Mode	I_{SD}	SE/BTL = 0V, SHUTDOWN = 0V		1		μA
High Input Current	I_{IH}			900		nA
Low Input Current	I_{IL}			900		nA

Operating Characteristics, BTL mode ($V_{DD} = 5\text{V}$, $R_L = 4\Omega$, Gain = 2V/V)

PARAMETER	SYMBOL	TEST CONDITIONS	MIN	TYP	MAX	UNIT
Maximum Output Power	P_{OUT}	THD+N=10%, $f_{IN}=1\text{kHz}$	$R_L=3\Omega$		2.9	W
			$R_L=4\Omega$		2.6	W
			$R_L=8\Omega$		1.6	W
		THD+N=1%, $f_{IN}=1\text{kHz}$	$R_L=3\Omega$		2.4	W
			$R_L=4\Omega$		1.8	W
			$R_L=8\Omega$	1	1.3	W
Total Harmonic Distortion Plus Noise	THD+N	$P_{OUT}=1.2\text{W}$, $R_L=4\Omega$, $f_{IN}=1\text{kHz}$		0.07		%
		$P_{OUT}=0.9\text{W}$, $R_L=8\Omega$, $f_{IN}=1\text{kHz}$		0.08		%
Power Ripple Rejection Ratio	PSRR	$V_{RR}=0.1\text{Vrms}$, $R_L=8\Omega$, $C_B=1\mu\text{F}$, $f_{IN}=120\text{Hz}$		60		dB
Channel Separation	Crosstalk	$C_B=1\mu\text{F}$, $R_L=8\Omega$, $f_{IN}=1\text{kHz}$		90		dB
Signal to Noise Ratio	S/N	$P_{OUT}=1.1\text{W}$, $R_L=8\Omega$, A Weighting		95		dB

■ ELECTRICAL CHARACTERISTICS(Cont.)

Operating Characteristics, SE mode ($V_{DD} = 5V$, Gain = 1V/V)

PARAMETER	SYMBOL	TEST CONDITIONS	MIN	TYP	MAX	UNIT	
Maximum Output Power	P_{OUT}	THD+N=10%, f_{IN} =1kHz	$R_L = 16\Omega$		220		mW
			$R_L = 32\Omega$		120		mW
		THD+N=1%, f_{IN} =1kHz	$R_L = 16\Omega$		160		mW
			$R_L = 32\Omega$		95		mW
Total Harmonic Distortion Plus Noise	THD+N	$P_{OUT}=125mW, R_L = 16\Omega, f_{IN}=1kHz$		0.09		%	
		$P_{OUT}=65mW, R_L = 32\Omega, f_{IN}=1kHz$		0.09		%	
Power Ripple Rejection Ratio	PSRR	$V_{IN}=0.1V_{rms}, R_L=8\Omega, C_B=1\mu F, f_{IN}=120Hz$		60		dB	
Channel Separation	Crosstalk	$C_B=1\mu F, R_L=32\Omega, f_{IN}=1kHz$		60		dB	
Signal to Noise Ratio	S/N	$P_{OUT}=75mW, SE, R_L=32\Omega, A$ Weighting		100		dB	

■ VOLUME CONTROL TABLE_BTL MODE (Supply Voltage $V_{DD}=5V$)

GAIN(DB)	HIGH(V)	LOW(V)	HYSTERESIS(MV)	RECOMMENDED VOLTAGE(V)
20	0.12	0.00		0
18	0.23	0.17	52	0.20
16	0.34	0.28	51	0.31
14	0.46	0.39	50	0.43
12	0.57	0.51	49	0.54
10	0.69	0.62	47	0.65
8	0.80	0.73	46	0.77
6	0.91	0.84	45	0.88
4	1.03	0.96	44	0.99
2	1.14	1.07	43	1.10
0	1.25	1.18	41	1.22
-2	1.37	1.29	40	1.33
-4	1.48	1.41	39	1.44
-6	1.59	1.52	38	1.56
-8	1.71	1.63	37	1.67
-10	1.82	1.74	35	1.78
-12	1.93	1.85	34	1.89
-14	2.05	1.97	33	2.01
-16	2.16	2.08	32	2.12
-18	2.28	2.19	30	2.23
-20	2.39	2.30	29	2.35
-22	2.50	2.42	28	2.46
-24	2.62	2.53	27	2.57
-26	2.73	2.64	26	2.69
-28	2.84	2.75	24	2.80
-30	2.96	2.87	23	2.91
-32	3.07	2.98	22	3.02
-34	3.18	3.09	21	3.14
-36	3.30	3.20	20	3.25
-38	3.41	3.32	18	3.36
-40	3.52	3.43	17	3.48
-80	5.00	3.54	16	5

■ TYPICAL APPLICATION CIRCUIT

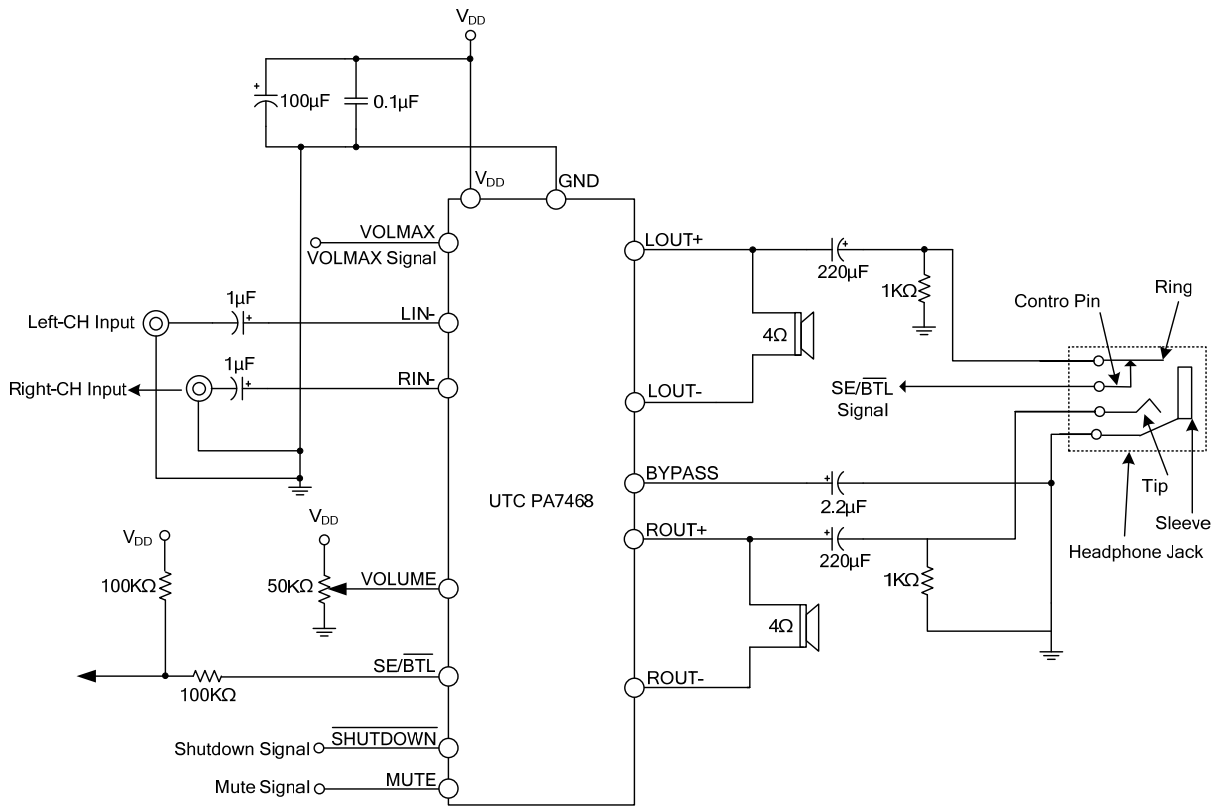

UTC assumes no responsibility for equipment failures that result from using products at values that exceed, even momentarily, rated values (such as maximum ratings, operating condition ranges, or other parameters) listed in products specifications of any and all UTC products described or contained herein. UTC products are not designed for use in life support appliances, devices or systems where malfunction of these products can be reasonably expected to result in personal injury. Reproduction in whole or in part is prohibited without the prior written consent of the copyright owner. The information presented in this document does not form part of any quotation or contract, is believed to be accurate and reliable and may be changed without notice.