



CD4541

CMOS IC

PROGRAMMABLE TIMER

DESCRIPTION

The CD4541 programmable timer comprise a 16-stage binary counter, an integrated oscillator for use with an external capacitor and two resistors, output control logic, and a special power-on reset circuit. The counter divides the oscillator frequency by any of 4 digitally controlled division ratios.

FEATURES

- * Operates at 2^n frequency divider or as single transition timer
- * Increments on positive edge clock transitions
- * Wide supply voltage range: 3.0V ~ 15V
- * Built-in low power RC oscillator
- * Oscillator frequency range ~ DC to 100 kHz
- * External clock applied to Pin 3 can be used instead of oscillator
- * Available division ratios 2^8 , 2^{10} , 2^{13} , or 2^{16}
- * High noise immunity: $0.45 V_{DD}$ (typ)
- * Master reset totally independent of automatic reset operation
- * Automatic reset initializes all counters when power turns on
- * Q/Q select provides output logic level flexibility
- * High output drive min. one TTL load
- * Maximum input leakage $1\mu A$ at 15V over full temperature range

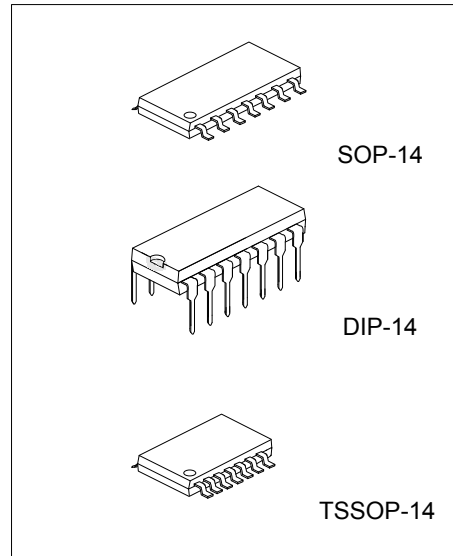

ORDERING INFORMATION

Ordering Number		Package	Packing
Lead Free	Halogen Free		
CD4541L-D14-T	CD4541G-D14-T	DIP-14	Tube
CD4541L-S14-R	CD4541G-S14-R	SOP-14	Tape Reel
CD4541L-S14-T	CD4541G-S14-T	SOP-14	Tube
CD4541L-P14-R	CD4541G-P14-R	TSSOP-14	Tape Reel
CD4541L-P14-T	CD4541G-P14-T	TSSOP-14	Tube

<p>CD4541L-S14-R</p> <p>(1) Packing Type (2) Package Type (3) Lead Free</p>	<p>(1) R: Tape Reel (2) D14: DIP-14, S14: SOP-14, P14: TSSOP-14 (3) G: Halogen Free, L: Lead Free</p>
---	---

PIN CONFIGURATION

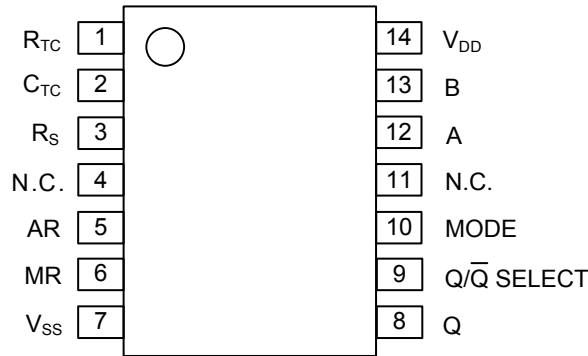

TRUTH TABLE

PIN	STATE	
	0	1
5	Auto Reset Operating	Auto Reset Disabled
6	Timer Operational	Master Reset On
9	Output Initially Low after Reset	Output Initially High after Reset
10	Single Cycle Mode	Recycle Mode

DIVISION RATIO TABLE

A	B	Number of Counter Stages	Count
		n	2 ⁿ
0	0	13	8192
0	1	10	1024
1	0	8	256
1	1	16	65536

BLOCK DIAGRAM

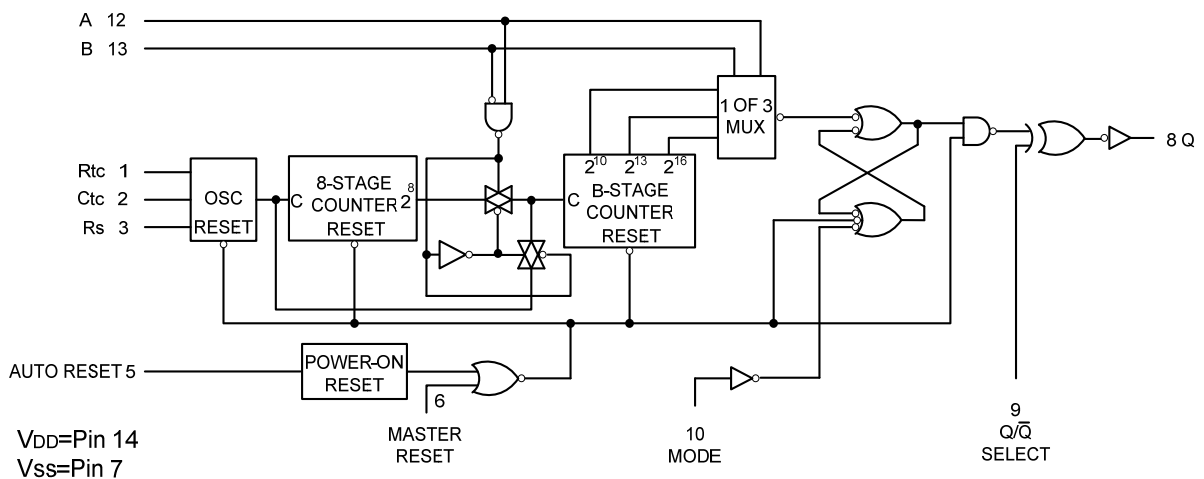

■ ABSOLUTE MAXIMUM RATING

PARAMETER		SYMBOL	RATINGS	UNIT
Supply Voltage		V_{DD}	-0.5 ~ +18	V
Input Voltage		V_{IN}	-0.5 ~ $V_{DD}+0.5$	V
Power Dissipation	DIP-14	P_D	700	mW
	SOP-14/ TSSOP-14		500	
Junction Temperature		T_J	125	°C
Operating Temperature		T_{OPR}	-20 ~ +85	°C
Storage Temperature		T_{STG}	-40 ~ +150	°C

Notes: Absolute maximum ratings are those values beyond which the device could be permanently damaged.

Absolute maximum ratings are stress ratings only and functional device operation is not implied.

■ RECOMMENDED OPERATING CONDITIONS

PARAMETER		SYMBOL	RATINGS	UNIT
Supply Voltage		V_{DD}	3 ~ 15	V
Input Voltage		V_{IN}	0 ~ V_{DD}	V
Operating Temperature		T_{OPR}	-40 ~ +85	°C

■ DC ELECTRICAL CHARACTERISTICS ($T_A=25^\circ\text{C}$, unless otherwise specified.)

PARAMETER	SYMBOL	TEST CONDITIONS	MIN	TYP	MAX	UNIT
Quiescent Device Current	I_{DD}	$V_{DD}=5\text{V}, V_{IN}=V_{DD}$ or V_{SS}		0.005	20	μA
		$V_{DD}=10\text{V}, V_{IN}=V_{DD}$ or V_{SS}		0.010	40	
		$V_{DD}=15\text{V}, V_{IN}=V_{DD}$ or V_{SS}		0.015	80	
Low Level Output Voltage	V_{OL}	$V_{DD}=5\text{V}$		0	0.05	V
		$V_{DD}=10\text{V}, I_{IO} < 1\mu\text{A}$		0	0.05	
		$V_{DD}=15\text{V}$		0	0.05	
High Level Output Voltage	V_{OH}	$V_{DD}=5\text{V}$	4.95	5		V
		$V_{DD}=10\text{V}, I_{IO} < 1\mu\text{A}$	9.95	10		
		$V_{DD}=15\text{V}$	14.95	15		
Low Level Input Voltage	V_{IL}	$V_{DD}=5\text{V}, V_O=0.5\text{V}$ or 4.5V		2	1.5	V
		$V_{DD}=10\text{V}, V_O=1.0\text{V}$ or 9.0V		4	3.0	
		$V_{DD}=15\text{V}, V_O=1.5\text{V}$ or 13.5V		6	4.0	
High Level Input Voltage	V_{IH}	$V_{DD}=5\text{V}, V_O=0.5\text{V}$ or 4.5V	3.5	3		V
		$V_{DD}=10\text{V}, V_O=1.0\text{V}$ or 9.0V	7.0	6		
		$V_{DD}=15\text{V}, V_O=1.5\text{V}$ or 13.5V	11.0	9		
Low Level Output Current (Note 1)	I_{OL}	$V_{DD}=5\text{V}, V_O=0.4\text{V}$	1.96	3.6		mA
		$V_{DD}=10\text{V}, V_O=0.5\text{V}$	2.66	9.0		
		$V_{DD}=15\text{V}, V_O=1.5\text{V}$	10.4	34.0		
High Level Output Current (Note 1)	I_{OH}	$V_{DD}=5\text{V}, V_O=2.5\text{V}$	4.27	130		mA
		$V_{DD}=10\text{V}, V_O=9.5\text{V}$	2.25	8.0		
		$V_{DD}=15\text{V}, V_O=13.5\text{V}$	8.8	30.0		
Input Current	I_{IN}	$V_{DD}=15\text{V}, V_{IN}=0\text{V}$		-10^{-5}	-0.3	μA
		$V_{DD}=15\text{V}, V_{IN}=15\text{V}$		10^{-5}	0.3	

Notes: 1. I_{OH} and I_{OL} are tested one output at a time.

■ **AC ELECTRICAL CHARACTERISTICS** (Note 1, $T_A=25^{\circ}\text{C}$, $C_L=50\text{pF}$ (refer to test circuits))

PARAMETER	SYMBOL	TEST CONDITIONS	MIN	TYP	MAX	UNIT
Output Rise Time	t_{TLH}	$V_{DD}=5\text{V}$		50	200	ns
		$V_{DD}=10\text{V}$		30	100	
		$V_{DD}=15\text{V}$		25	80	
Output Fall Time	t_{THL}	$V_{DD}=5\text{V}$		50	200	ns
		$V_{DD}=10\text{V}$		30	100	
		$V_{DD}=15\text{V}$		25	80	
Turn-Off, Turn-On Propagation Delay, Clock to Q (2^8 Output)	t_{PLH}, t_{PHL}	$V_{DD}=5\text{V}$		1.8	4.0	μs
		$V_{DD}=10\text{V}$		0.6	1.5	
		$V_{DD}=15\text{V}$		0.4	1.0	
Turn-On, Turn-Off Propagation Delay, Clock to Q (2^{16} Output)	t_{PHL}, t_{PLH}	$V_{DD}=5\text{V}$		3.2	8.0	μs
		$V_{DD}=10\text{V}$		1.5	3.0	
		$V_{DD}=15\text{V}$		1.0	2.0	
Clock Pulse Width	$t_{WH(CL)}$	$V_{DD}=5\text{V}$	400	200		ns
		$V_{DD}=10\text{V}$	200	100		
		$V_{DD}=15\text{V}$	150	70		
Clock Pulse Frequency	f_{CL}	$V_{DD}=5\text{V}$		2.5	1.0	MHz
		$V_{DD}=10\text{V}$		6.0	3.0	
		$V_{DD}=15\text{V}$		8.5	4.0	
MR Pulse Width	$t_{WH(R)}$	$V_{DD}=5\text{V}$	400	170		ns
		$V_{DD}=10\text{V}$	200	75		
		$V_{DD}=15\text{V}$	150	50		
Average Input Capacitance	C_I	Any Input		5.0	7.5	pF
Power Dissipation Capacitance	C_{PD}	(Note 2)		100		pF

Notes: 1. AC Parameters are guaranteed by DC correlated testing.

2. C_{PD} determines the no load AC power consumption of any CMOS device.

■ OPERATING CHARACTERISTICS

With Auto Reset pin set to a "0" the counter circuit is initialized by turning on power. Or with power already on, the counter circuit is reset when the Master Reset pin is set to a "1". Both types of reset will result in synchronously resetting all counter stages independent of counter state.

The RC oscillator frequency is determined by the external RC network, i.e.:

$$f = \frac{1}{2.3 R_{TC} C_{TC}} \text{ if } (1 \text{ kHz} \leq f \leq 100 \text{ kHz})$$

and $R_S \sim 2 R_{TC}$ where $R_S \geq 10 \text{ k}\Omega$

The time select inputs (A and B) provide a two-bit address to output any one of four counter stages (2^8 , 2^{10} , 2^{13} , and 2^{16}). The 2^n counts as shown in the Division Ratio Table represent the Q output of the Nth stage of the counter. When A is "1", 2^{16} is selected for both states of B.

However, when B is "0", normal counting is interrupted and the 9th counter stage receives its clock directly from the oscillator (i.e., effectively outputting 2^8).

The Q/\bar{Q} select output control pin provides for a choice of output level. When the counter is in a reset condition and Q/\bar{Q} select pin is set to a "0" the Q output is a "0". Correspondingly, when Q/\bar{Q} select pin is set to a "1" the Q output is a "1".

When the mode control pin is set to a "1", the selected count is continually transmitted to the output. But, with mode pin "0" and after a reset condition the RS flip-flop resets (see Logic Diagram), counting commences and after 2^{n-1} counts the RS flip-flop sets which causes the output to change state. Hence, after another 2^{n-1} counts the output will not change. Thus, a Master Reset pulse must be applied or a change in the mode pin level is required to reset the single cycle operation.

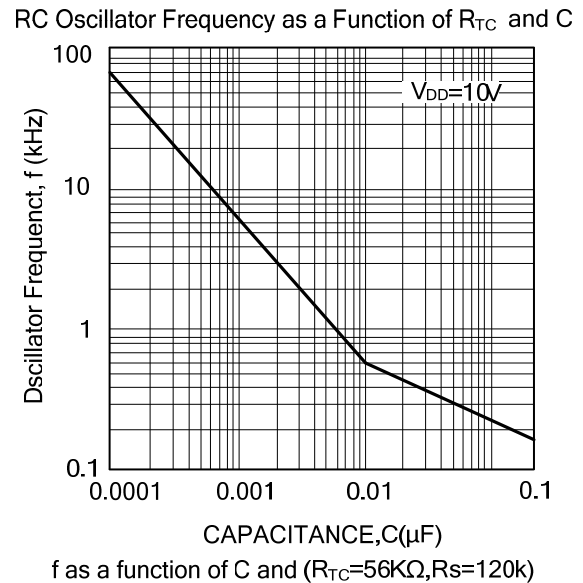
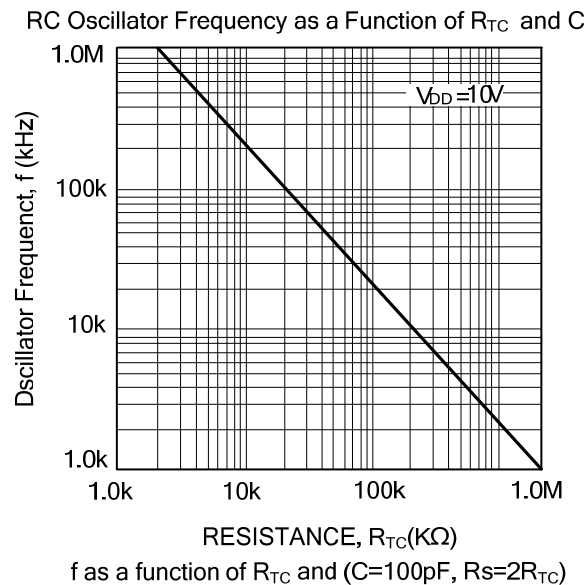

Oscillator Circuit Using RC Configuration

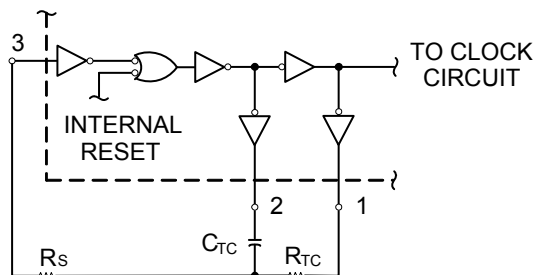

■ TEST CIRCUIT AND WAVEFORMS

Power Dissipation Test Circuit and Waveforms

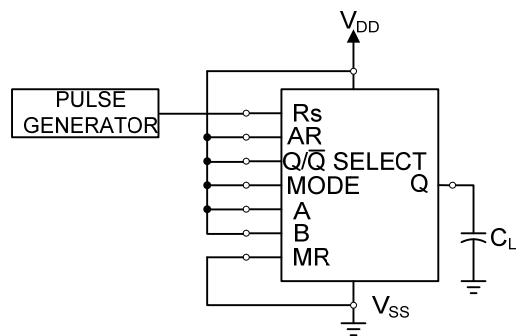

(Rtc and Ctc outputs are left open)

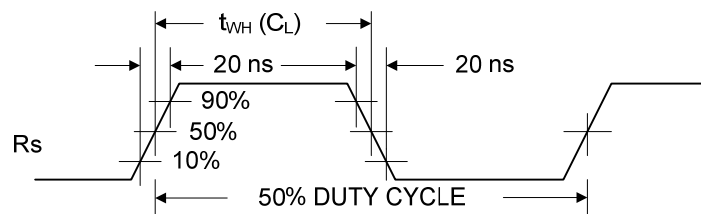

Switching Time Test Circuit and Waveforms

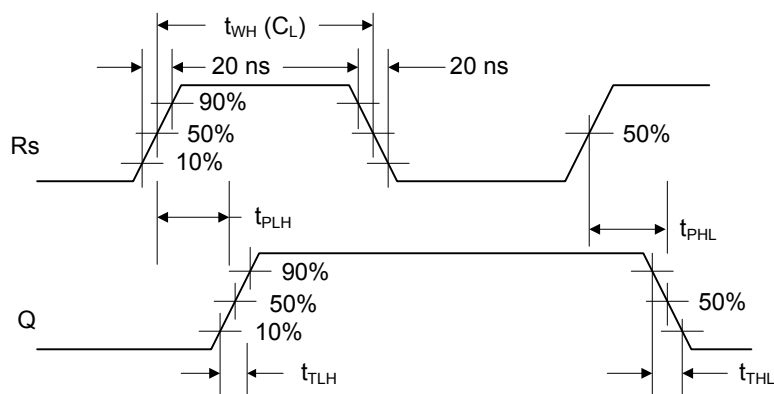
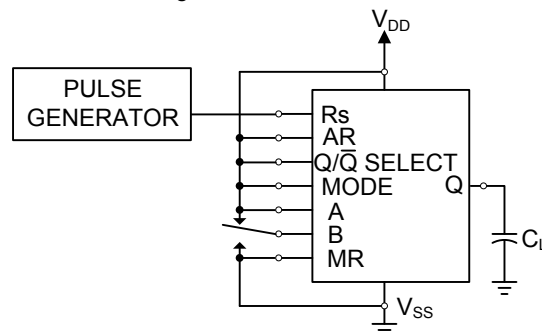

UTC assumes no responsibility for equipment failures that result from using products at values that exceed, even momentarily, rated values (such as maximum ratings, operating condition ranges, or other parameters) listed in products specifications of any and all UTC products described or contained herein. UTC products are not designed for use in life support appliances, devices or systems where malfunction of these products can be reasonably expected to result in personal injury. Reproduction in whole or in part is prohibited without the prior written consent of the copyright owner. The information presented in this document does not form part of any quotation or contract, is believed to be accurate and reliable and may be changed without notice.