



L6726

LINEAR INTEGRATED CIRCUIT

UNIVERSAL SPEECH CIRCUIT

DESCRIPTION

The UTC **L6726** is a mask-programmable, monolithic integrated speech circuits for using in electronic telephones.

It is designed for using with a low impedance microphone. Transmitting and receiving gain are regulated with line length. Different regulation for various current feeds can be set by external resistors. Typical current feeds as 48V 2-200Ω, 48V, 2-400Ω, and 36V, 2-500Ω, can be handled. Application dependent parameters such as line balance, side tone level, amplification and frequency response are set by external components. Parameters are set independently which means easy adaptation for various market needs.

The UTC **L6726** is developed for using with CMOS-type dialer ICs. A separate DTMF input is switched when the circuit is muted, and an adjustable DC supply is provided for feeding an external CMOS device.

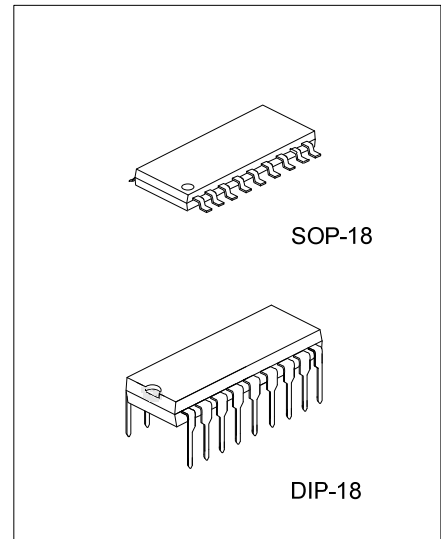

FEATURES

- *Minimum number of inexpensive external components, 5 capacitors and 11 resistors.
- *Mute function for operation with DTMF-generator.
- *Transmit and receive gain regulation for automatic loop loss compensation.
- *Extended current and voltage range 5~130mA, down to 2V.
- *Differential microphone input for good balance to ground.
- *Balanced receiver output stage.
- *Short start-up time.
- *Stabilized DC-supply for low current CMOS dialers and/or electret microphones.
- *DTMF-input controlled by mute.

ORDERING INFORMATION

Ordering Number		Package	Packing
Lead Free	Halogen Free		
L6726L-D18-T	L6726G-D18-T	DIP-18	Tube
L6726L-S18-R	L6726G-S18-R	SOP-18	Tape Reel
L6726L-S18-T	L6726G-S18-T	SOP-18	Tube

<p>L6726L-D18-T</p> <p>(1)Packing Type (2)Package Type (3)Lead Free</p>	<p>(1) T: Tube, R: Tape Reel (2) D18: DIP-18, S18: SOP-18 (3) G: Halogen Free, L: Lead Free</p>
---	---

■ PIN CONFIGURATION

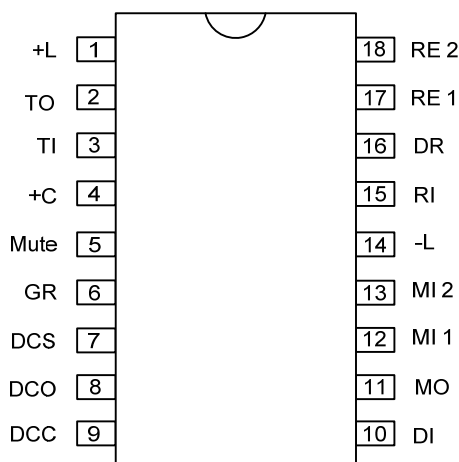

■ PIN DESCRIPTIONS

Pin No.	Pin Name	Description
1	+L	Output of the DC-regulator and transmit amplifier. This pin is connected to the line through a polarity guard and diode bridge.
2	TO	Output of the transmit amplifier. This pin is connected through a resistor of 47 to 100Ω to -L, which sets the DC-resistance of the circuit. The output has a low AC output impedance and the signal is used to drive a side tone balancing network.
3	TI	Input of transmit amplifier. Input impedance 17kΩ±20%
4	+C	The positive power supply terminal for most of the circuitry inside the UTC L6726 (about 1mA current consumption). The +C-PIN shall be connected to a decoupling capacitor of 47μF to 150μF
5	Mute	When low, speech circuit is muted and the DTMF input is enabled. Maximum voltage (at mute) is 0.3V, current sink requirement of external driver is 50μA
6	GR	Control input for the gain regulation circuitry.
7	DCS	The sense input to the DC-supply.
8	DCO	The output from the DC-supply.
9	DCC	The control output from the DC-supply
10	DI	The input for the DTMF-signal. Input impedance is 25kΩ±20%
11	MO	Output of the microphone amplifier or DTMF-amplifier
12	MI 1	Input to the microphone amplifier. Input impedance 1.7kΩ±20%
13	MI 2	
14	-L	The negative power terminal, connected to the line through a polarity guard diode bridge
15	RI	Input of receiver amplifier. Input impedance is approximately 38kΩ±20%
16	DR	The control input for the receiver amplifier driving capability.
17	RE 1	Receiver amplifier outputs. Output impedance is approximately 3Ω.
18	RE 2	

■ ABSOLUTE MAXIMUM RATINGS

PARAMETER	SYMBOL	RATINGS	UNIT
Line Voltage, $t_p=2s$	V_L	0~22	V
Line Current, Continuous	I_L	0~130	mA
Operating Temperature	T_{OPR}	-40~+70	°C
Storage Temperature	T_{STG}	-55~+125	°C

Note: Absolute maximum ratings are those values beyond which the device could be permanently damaged.

Absolute maximum ratings are stress ratings only and functional device operation is not implied.

■ ELECTRICAL CHARACTERISTICS ($T_A=25^\circ\text{C}$ unless otherwise specified)

PARAMETER	FIG.	TEST CONDITIONS	MIN	TYP	MAX	UNIT	
Line Voltage	1	$I_L=15\text{mA}$	3.3	3.7	4.1	V	
		$I_L=100\text{mA}$	11	13	15		
Transmitting Gain, Note 1	1	20·10log(V_2/V_3), 1kHz	$R_L=0\Omega$	41	43	45	dB
			$R_L=400\Omega$	43.5	45.5	47.5	
			$R_L=900\Omega\sim 2.2\text{k}\Omega$	46	48	50	
Transmitting Range Of Regulation	1	1kHz, $R_L=0\sim 900\Omega$	3	5	7	dB	
Transmitting Frequency Response	1	200Hz ~ 3.4kHz	-1		1	dB	
Receiving Gain, Note 1	1	20·10log (V_4/V_1), 1kHz	$R_L=0\Omega$	-18.5	-16.5	-14.5	dB
			$R_L=400\Omega$	-16	-14	-12	
			$R_L=900\Omega\sim 2.2\text{k}\Omega$	-13.5	-11.5	-9.5	
Receiving Range Of Regulation	1	1kHz, $R_L=0\sim 900\Omega$	3	5	7	dB	
Receiving frequency response	1	200Hz ~ 3.4kHz	-1		1	dB	
Microphone Input Impedance Pin12,13	1	1kHz, note 3		1.7(//2.7)		k Ω	
Transmitter Input Impedance Pin 3	1	1kHz		17		k Ω	
Transmitter Dynamic Output	1	200Hz~3.4kHz, $\leq 2\%$ distortion, $I_L=20\sim 100\text{mA}$		1.5		Vp	
Transmitter Max Output	1	200 Hz~3.4kHz, $I_L=0\sim 100\text{mA}$, $V_3=0.1\text{V}$		3		Vp	
Receiver Output Impedance	1	1kHz, note 3		3(+310)		Ω	
Receiver Dynamic Output (Note 2)	1	200Hz~3.4kHz $\leq 2\%$ distortion, $I_L=20\sim 100\text{mA}$		0.5		Vp	
Receiver Max Output	2	Measured with line rectifier 200 Hz~3.4kHz, $I_L=0\sim 100\text{mA}$, $V_1=0\sim 50\text{V}$		0.9		Vp	
Transmitter Output Noise	1	P_{SOF} -weighting, Rel1 V_{RMS} , $R_L=0$		-75		dB P_{SOF}	
Receiver Output Noise	1	A-weighting, Rel 1 V_{RMS} , with cable 0~5km, $\phi=0.5\text{mm}$, 0~3km, $\phi=0.3\text{mm}$		-85		dBA	
Mute Input Voltage at Mute (Active Low)	1				0.3	V	
DC-Supply Voltage	1	$I_L=10\sim 100\text{mA}$, $I_{DC}=0\text{mA}$		2.35		V	
		$I_L=10\sim 100\text{mA}$, $I_{DC}=2\text{mA}$		2.2			
DC-Supply Current, Pin8	1		2			mA	
Dc-Output Pin8 Input Leakage Current (No Supply)	3	$V_{DC}=2.35\text{V}$		0.1		μA	
DTMF Transmitting Gain	1	$V_M=0.3\text{V}$	24.5	26.5	28.5	dB	

Notes: 1. Adjustable to both higher and lower values with external components.

2. The dynamic output can be doubled, see applications information.

3. External resistor in the test set up.

FUNCTIONAL DIAGRAM

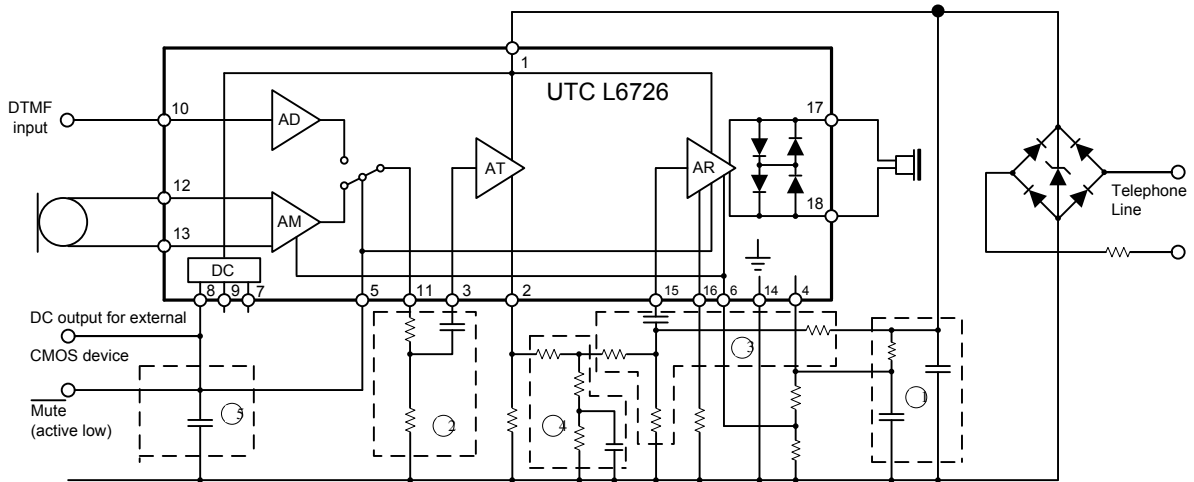

1. Impedance to line and radio interference suppression.
2. Transmit gain and frequency response network.
3. Receive gain and frequency response network.
4. Side tone balance network.
5. DC-supply components.

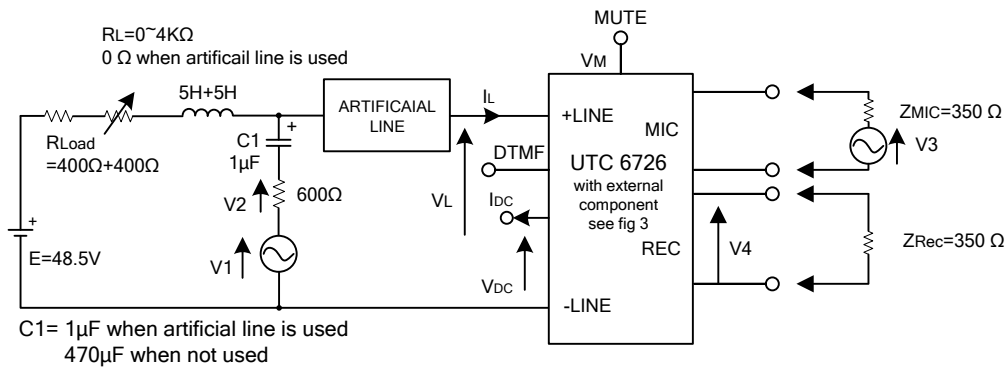

Fig. 1 Test setup without rectifier bridge

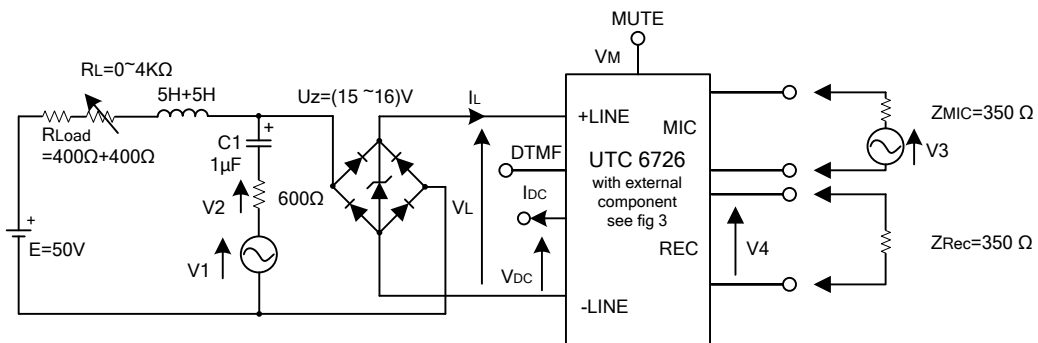

Fig. 2 Test setup with rectifier bridge

FUNCTIONAL DIAGRAM(Cont.)

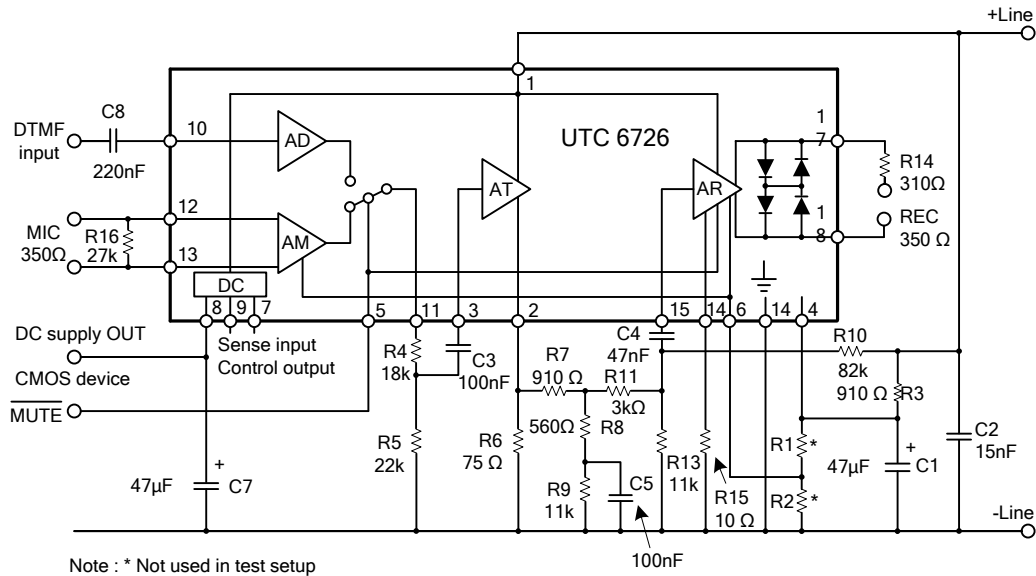

Fig. 3 Circuit with external components for test setup.

■ FUNCTIONAL DESCRIPTION

The gain of the transmitting and receiving amplifiers are continuously and equally changed with the line length. The starting point for the gain regulation is externally set. The gain regulation can be cut-off externally, see table under gain regulation below.

The outputs of the transmitting and receiving amplifiers have internal limitations of the output amplitudes.

The circuit includes a temperature independent voltage reference used for regulation of the DC line voltage and for the transmitting and receiving gain regulation. The DC voltage is very fast settled to its final value with a minimum of overshoot.

The circuit uses a minimum of external components. In a normal practical case only 5 external capacitors of which only one is an electrolytic/tantalum filter capacitor. The other capacitors are needed as radio interference suppression capacitors over the line, one capacitor in the side-tone balancing network and one capacitor for low frequency cut-off in each of the transmitting and receiving amplifiers. The frequency response is except for that, flat for both amplifiers.

The circuit will with external components get a very good return loss behavior both against purely resistive lines as for instance 600 Ω and against complex networks as 900 Ω in parallel with 30nF.

To get a good CMRR the microphone input is balanced.

It is possible to add a push-button controlled cut-off of the transmitting amplifier to the circuit without any disturbance of the other circuit functions

A mute input is included in the circuit. It gives:

1. Cut-off the microphone amplifier.
2. Reduced gain in the receiving amplifier.
3. Connection of the DTMF input.

The receiver amplifier is equipped with a high impedance input stage. This gives a less expensive RC-network on the input.

Only resistive elements are used to set the receiving gain.

A push-pull power stage in the receiving amplifier gives a high output swing.

To get the extended low current and voltage range two resistors have to be connected from microphone input to ground.

The side-tone balanced can be set by a RC-network without influence on other parameters. An inexpensive solution requires only one capacitor while more capacitors can give better performance.

In fig.4 ①②③ and ④ are RC-links with the following functions:

1. For radio interference suppression and to give the correct return loss behavior.
2. To set the gain and frequency response for transmitting.
3. To set the gain and frequency response for receiving.
4. To set the side-tone level

A stabilized DC output, with a pre-set output voltage of 2.35V, is provided to facilitate interfacing to external COMS dialer ICs. The voltage is adjustable with two resistors, as indicated in fig.5. The output requires some filtering to avoid distortion on the telephone line. Note that a high current consumption of the external device will alter the DC characteristics of the speech circuit.

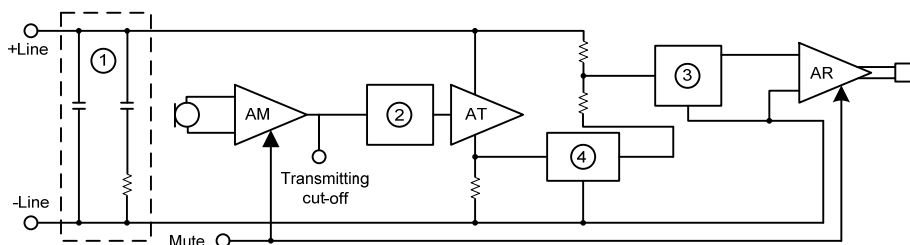

Fig. 4 Block interconnections

FUNCTIONAL DESCRIPTION(Cont.)

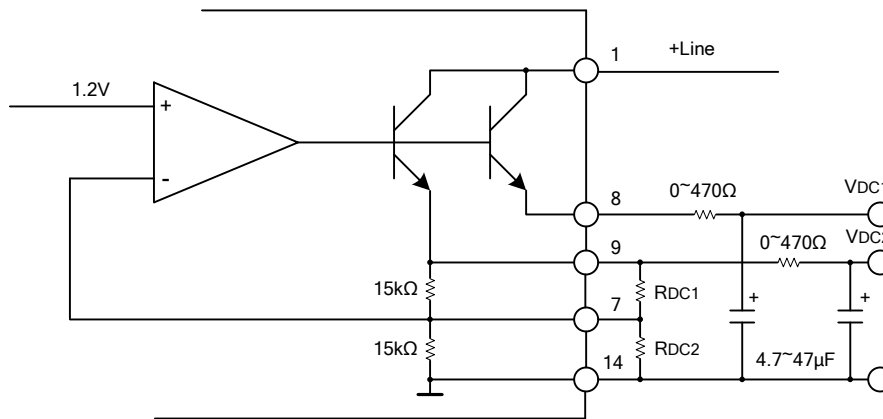

Fig. 5 DC regulator for external CMOS devices

■ APPLICATION INFORMATION

Refer to fig. 6

Gain regulation (R1, R2):

These resistors set the starting point for the gain-and side tone regulation.

Input impedance pin 6 is about 5.5 kΩ±20%.

Below are some typical values for R1 and R2, for some different supplies from telephone stations.

Battery feed	R1	R2	R6
No regulation Set for short line gain. All feedings		22kΩ	47~100Ω
Regulation: 48V, 2·200Ω	∞	∞	47Ω
48V, 2·400Ω	∞	∞	75Ω
36V, 2·500Ω		180kΩ	100Ω

Impedance to line (R3, C1, C2):

C1 in series with R3 and those in parallel with C2 give the impedance to the line from the set.

C2 must normally be there for the interference too.

The network is optimized with regard to the return loss.

The time constant R3, C1 cannot be allowed to be too small. If the time constant is too small, distortion at low frequencies may be generated.

If R3 is changed this will change the DC-characteristic too, which is set by the voltage at pin 4. The input current at pin 4 is about 1mA

Microphone selection (M1, R16):

The microphone can be either dynamic, magnetic or electrets. See fig. 12, 14 and 15.

The input impedance between pin 12 and 13 is about 1.7kΩ with typical variation ±20%

Transmitting gain and frequency response (R4, R5, C3, C4):

The network gives the amplification and frequency response for the transmitter. R5 is used when a greater reduction of the gain is wanted. Input impedance at pin 3 is about 17 kΩ with typical variation ±20%. The sum of the resistors R4 and R5 must not be less than 35 kΩ because of DC-current to ground. Below are some simple variations of this network. (See fig. 7).

DC-characteristics (R6):

Sets the DC-characteristic and takes care of some of the supplied power. The resistor also has a function with the protection of the circuit, the transmitter, the gain regulation and side tone. Common values are 47 Ω to 100 Ω.

Side tone level, receiving gain and frequency response.(R7,R8,R9,R10,R11,C5):

The network sets the side tone balance. The network in the application is one of many possibilities. R10 and R11 balance together the signals that go two different ways from the transmitter output stage one from pin1 and the other from pin2. The balance network consists of R8, R9 and C5.

The example is not optimized to any specified line, it is only given to show the principle.

Fig8, 9 and 10 are examples of balance networks. Fig.10 is especially suited for lines with high current supply.

R12, R13, C6, (R10, R11):

The network gives the gain and frequency response for the receiver.

Input impedance at pin 15 is about 38 kΩ with a typical variation of ±20%. For different possibilities for the design of the network, see the network for the transmitter (R4, R5, C3)

REC, R14:

R14 generates the output impedance to the magnetic earphone (fig.11). If a dynamic earphone is used it should be placed between pin 17 and 18. See fig. 16.

■ APPLICATION INFORMATION(Cont.)

R15:

This resistor is used to set the driving capability of the receiver output amplifier. Common values are 0 Ω to 50 Ω . Setting it for low driving capability results in function at lower line current. Breaking up pin 16 will give lower power consumption and total mute of the receiver when muting the circuit. Disconnecting pin 15 will of cause also give total receiver mute.

D1, D2, D3, D4, D5:

Rectifier bridge and over voltage protector. The zener voltage at D5 should be as low as possible. Common values are between 12V~16V.

R_{DC1}, R_{DC2}:

Refer to fig. 5

The pre-set output voltage of 2.35V can easily, if needed, be changed to another value by applying one or two resistor(R_{DC1},R_{DC2}) in parallel with the internal resistors (each 15k Ω +/-20%).It is possible to get a rather high voltage and current from the DC-supply as long as the high current and voltage is available from the line. The DC voltage has to be filtered by a capacitor and this can, at high DC-voltage and low line current, interfere with the signal on the line and cause distortion. You can minimize the interference, with a resistor in series with the filter capacitor. The DC voltage will, of course, be more dependent of the DC-supply current. The DC-output pin has a very low input leak current, to allow stand-by feeding of the dialer. It is also possible to use pin 9 to feed microphones etc. that do not need stand-by feeding, without interfering with the stand-by feeding on pin 8. Note that a high current consumption by the external device will alter the DC characteristics of the speech circuit

■ APPLICATION INFORMATION(Cont.)

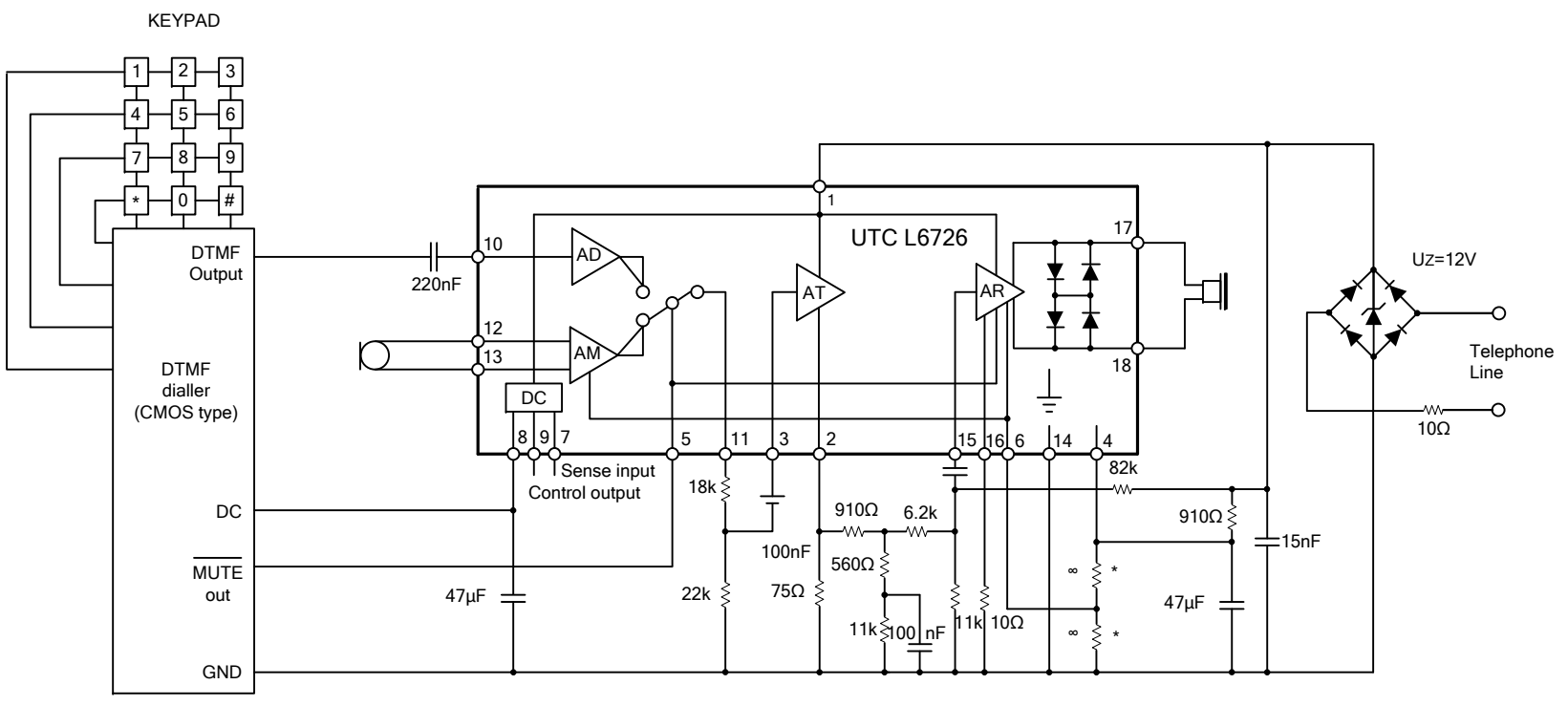

Note : * Not used in test setup

Fig. 6 Typical tong dialling telephone

APPLICATION INFORMATION(Cont.)

DESIGN PROCEDURE:

1. Circuit impedance to the line.
2. DC-characteristic
3. Gain regulation.
4. Transmitter gain and frequency response.
5. Receiver gain and frequency response.
6. Side-tone.
7. Components to suppress radio interference, specially the wires up to the handset.

Others:

The circuit can be placed either in the telephone or in the handset.

Cut off the transmitter can be done at F1 without interference of other functions of the circuit.

When using the extended low current and low voltage range (5mA, 2V), two resistors have to be connected from the microphone inputs to ground as shown in fig. 13.

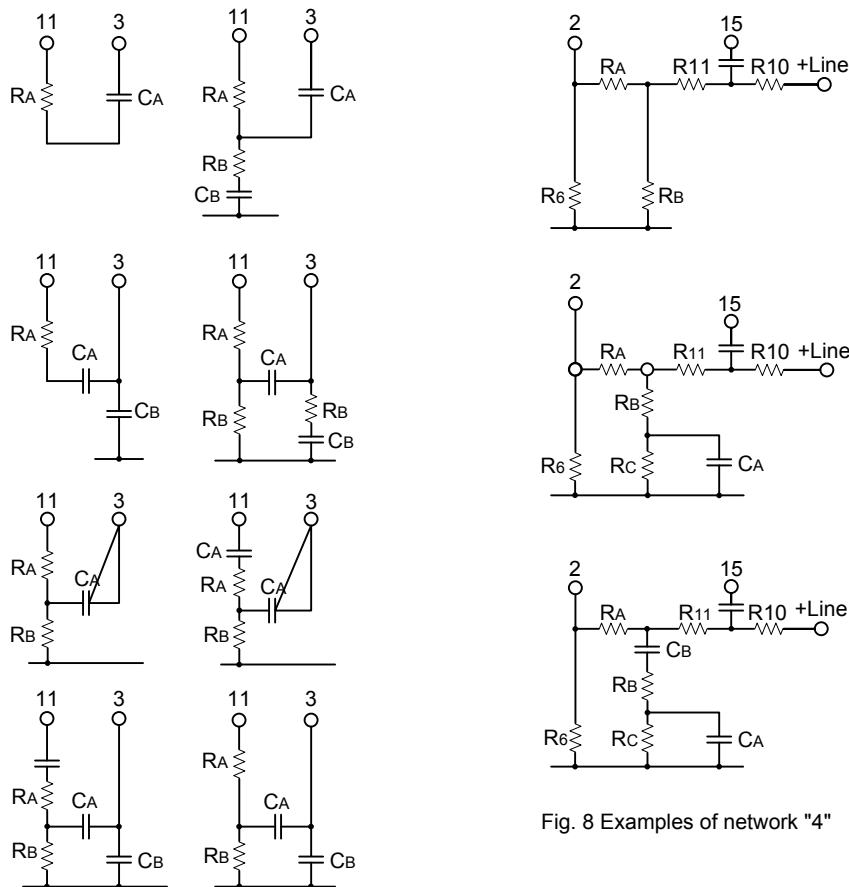

Fig. 7 Examples of network "2"

Fig. 8 Examples of network "4"

■ APPLICATION INFORMATION(Cont.)

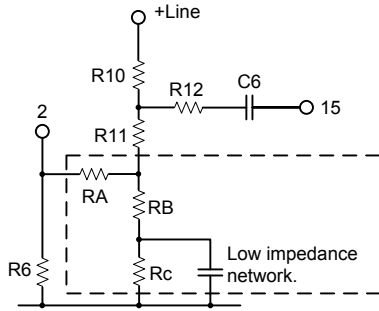

Fig. 9 Typical sidetone network

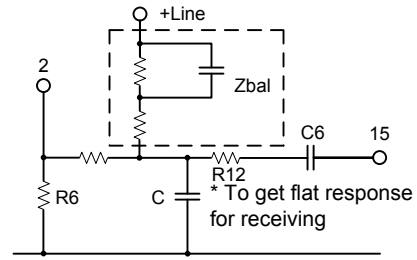

Fig. 10 Sidetone network especially suited for applicatons with a high line current,when R6 has a low value

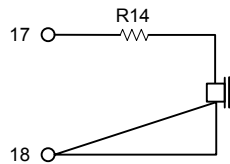

Fig.11 Magnetic reciever connection

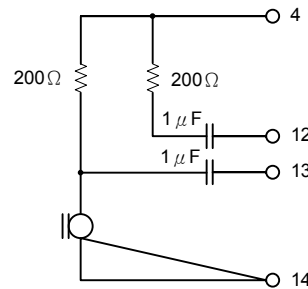

Fig. 12 Electret microphone with FET buffer

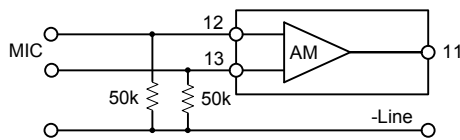

Fig. 13 Additional components for extended low current/voltage oeration

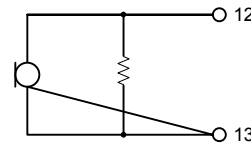

Fig. 14 Connection of a magnetic microphone

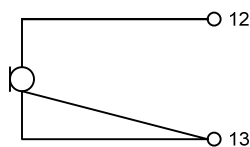

Figure 15. Connection of a dynamic microphone

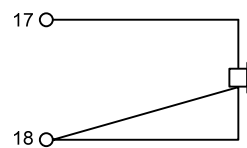

Figure 16. Dynamic reviever connection

UTC assumes no responsibility for equipment failures that result from using products at values that exceed, even momentarily, rated values (such as maximum ratings, operating condition ranges, or other parameters) listed in products specifications of any and all UTC products described or contained herein. UTC products are not designed for use in life support appliances, devices or systems where malfunction of these products can be reasonably expected to result in personal injury. Reproduction in whole or in part is prohibited without the prior written consent of the copyright owner. The information presented in this document does not form part of any quotation or contract, is believed to be accurate and reliable and may be changed without notice.