



TEA1110A

LINEAR INTEGRATED CIRCUIT

LOW VOLTAGE VERSATILE TELEPHONE TRANSMISSION CIRCUIT WITH DIALLER INTERFACE

DESCRIPTION

The UTC **TEA1110A** is a versatile telephone transmission circuit providing full speech and line interface functions in electronic telephone sets. This device works at a line voltage which can be as low as 1.6V DC (with reduced performance) to enable parallel connection of telephone sets. It also realizes electronic switching between speeches and dialling.

The UTC **TEA1110A** is ideal for applications, such as line powered telephone sets, cordless telephones, and fax machines, answering machines.

FEATURES

- * Low DC line voltage; operates down to 1.6V (excluding voltage drop over external polarity guard)
- * Voltage regulator with adjustable DC voltage
- * Provides a supply for external circuits
- * Symmetrical high impedance inputs (64kΩ) for dynamic, magnetic or piezo-electric microphones
- * Asymmetrical high impedance input (32kΩ) for electric microphones
- * DTMF input with confidence tone
- * $\overline{\text{MUTE}}$ input for pulse or DTMF dialling
- * Receiving amplifier for dynamic, magnetic or piezo-electric earpieces
- * AGC line loss compensation for microphone and earpiece amplifiers.

ORDERING INFORMATION

Ordering Number		Package	Packing
Lead Free	Halogen Free		
TEA1110AL-D14-T	TEA1110AG-D14-T	DIP-14	Tube
TEA1110AL-S14-R	TEA1110AG-S14-R	SOP-14	Tape Reel

<p>TEA1110AL-D14-T</p> <p>(1)Packing Type (2)Package Type (3)Lead Free</p>	<p>(1) T: Tube, R: Tape Reel (2) D14: DIP-14, S14: SOP-14 (3) G: Halogen Free, L: Lead Free</p>
--	---

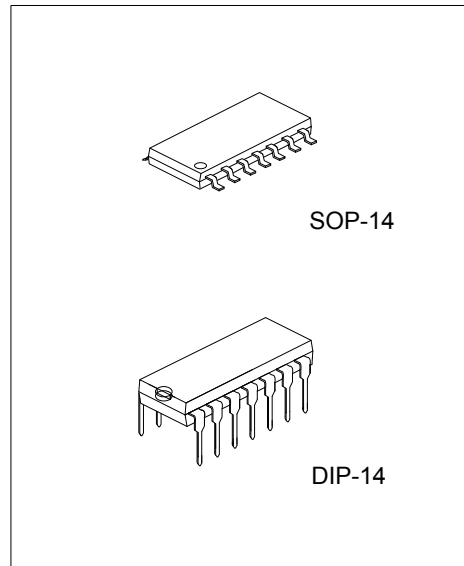

■ PIN CONFIGURATION

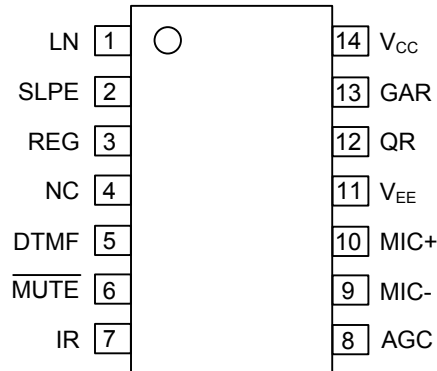

■ PIN DESCRIPTION

PIN NO.	PAD NO.	SYMBOL	DESCRIPTION
1	1	LN	Positive line terminal
2	2	SLPE	Slope (DC resistance) adjustment
3	3	REG	Line voltage regulator decoupling
4	4	NC	Not connected
5	5	DTMF	Dual-tone multi-frequency input
6	6	$\overline{\text{MUTE}}$	Mute input to select speech or dialing mode (active LOW)
7	7	IR	Receiving amplifier input
8	8	AGC	Automatic gain control/line loss compensation
9	9	MIC-	Inverting microphone amplifier input
10	10	MIC+	Non-inverting microphone amplifier input
11	11	V_{EE}	Negative line terminal
12	12	QR	Earpiece amplifier output
13	13	GAR	Earpiece amplifier gain adjustment
14	14	V_{CC}	Supply voltage for internal circuit

■ ABSOLUTE MAXIMUM RATINGS

PARAMETER	SYMBOL	RATINGS	UNIT
Positive Continuous Line Voltage	V_{LN}	$V_{EE}-0.4 \sim 12$	V
Repetitive Line Voltage During Switch-on or Line Interruption		$V_{EE}-0.4 \sim 13.2$	V
Maximum Voltage On All Pins	$V_{N(MAX)}$	$V_{EE}-0.4 \sim V_{CC}+0.4$	V
Maximum Line Current ($R_{SLPE}=20\Omega$)	I_{LINE}	140	mA
Power Dissipation ($T_a=75^\circ\text{C}$)	DIP-14	P_D	588
	SOP-14		384
Junction Temperature	T_J	125	$^\circ\text{C}$
Ambient Temperature	T_{OPR}	$-25 \sim +75$	$^\circ\text{C}$
Storage Temperature	T_{STG}	$-40 \sim +125$	$^\circ\text{C}$

Note: Absolute maximum ratings are those values beyond which the device could be permanently damaged. Absolute maximum ratings are stress ratings only and functional device operation is not implied.

■ THERMAL DATA

PARAMETER	SYMBOL	RATINGS	UNIT
Junction to Ambient	θ_{JA}	85	$^\circ\text{C/W}$
		130	$^\circ\text{C/W}$

Note: Mounted on epoxy board

■ ELECTRIC CHARACTERISTICS ($T_a=25^\circ\text{C}$, unless otherwise specified)

($I_{LINE}=15\text{mA}$, $V_{EE}=0\text{V}$, $R_{SLPE}=20\Omega$, AGC pin connected to V_{EE} , $Z_{LINE}=600\Omega$, $f=1\text{kHz}$)

PARAMETER	SYMBOL	CONDITIONS	MIN	TYP	MAX	UNIT
Supplies (pins VLN, VCC, SLPE and REG)						
Stabilized Voltage Between LN and SLPE	V_{REF}		3.1	3.35	3.6	V
DC Line Voltage	V_{LN}	$I_{LINE}=1\text{mA}$		1.6		V
		$I_{LINE}=4\text{mA}$		2.3		V
		$I_{LINE}=15\text{mA}$	3.35	3.65	3.95	V
		$I_{LINE}=140\text{mA}$			6.9	V
DC line voltage with an external resistor RVA	$V_{LN(exR)}$	$R_{VA(SLPE-REG)} = 27\text{k}\Omega$		4.4		V
DC line voltage variation with temperature referred to 25°C	$V_{LN(T)}$	$T_a = -25 \sim +75^\circ\text{C}$		± 30		mV
internal current consumption	I_{CC}	$V_{CC} = 2.9\text{V}$		1.3	1.48	mA
Supply voltage for peripherals	V_{CC}	$I_P=0\text{mA}$		2.9		V
Equivalent supply voltage resistance	$R_{CC(int)}$	$I_P=0.5\text{mA}$		550	620	Ω
Microphone amplifier (pins MIC+ and MIC-)						
Voltage gain from MIC+/MIC- to LN	G_{VTX}	$V_{MIC}=4\text{mV (RMS)}$	42.7	43.7	44.7	dB
Gain variation with frequency referred to 1kHz	$G_{VTX(F)}$	$f=300\sim 3400\text{Hz}$		± 0.2		dB
Gain variation with temperature referred to 25°C	$G_{VTX(T)}$	$T_a = -25 \sim +75^\circ\text{C}$		± 0.3		dB
Common mode rejection ratio	CMRR			80		dB
Maximum sending signal (RMS value)	$V_{LN(MAX)}$ (rms)	$I_{LINE}=15\text{mA}$; THD=2%	1.4	1.7		V
		$I_{LINE}=4\text{mA}$; THD=10%		0.8		V
Noise output voltage at pin LN, pins MIC+/MIC- shorted through 200Ω	V_{NOTX}			-78.5		dBmp

■ ELECTRIC CHARACTERISTICS(Cont.)

PARAMETER	SYMBOL	CONDITIONS	MIN	TYP	MAX	UNIT
Receiving amplifier (pins IR, QR and GAR)						
Voltage gain from IR to QR	G_{VRX}	$V_{IR} = 4\text{mV (RMS)}$	32	33	34	dB
Gain variation with frequency referred to 1kHz	$G_{VRX(F)}$	$f = 300\sim 3400\text{ Hz}$		± 0.2		dB
Gain variation with temperature referred to 25°C	$G_{VRX(T)}$	$T_a = -25 \sim +75\text{ }^\circ\text{C}$		± 0.3		dB
Gain voltage reduction range	G_{VRXR}	external resistor connected between GAR and QR			14	dB
Maximum receiving signal (RMS value)	$V_{O(rms)}$	$I_P = 0\text{mA sine wave drive}$ $R_L = 50\Omega, \text{THD} = 2\%$		0.25		V
		$I_P = 0\text{mA sine wave drive}$ $R_L = 450\Omega, \text{THD} = 2\%$		0.35		
Noise output voltage at pin R (RMS value)	$V_{NORX(rms)}$	$G_{VRX} = 33\text{dB}$, IR open-circuit, $R_L = 150\Omega$		-87		dBVp
Automatic gain control (pin AGC)						
Gain control range for microphone and receiving amplifiers with respect to $I_{LINE} = 15\text{mA}$	G_{VTRX}	$I_{LINE} = 85\text{mA}$		5.9		dB
Highest line current for maximum gain	I_{START}			23		mA
Lowest line current for minimum gain	I_{STOP}			56		mA
DTMF amplifier (pin DTMF)						
Voltage gain from DTMF to LN	G_{VDTMF}	$V_{DTMF} = 20\text{mV (RMS)}$ $\overline{\text{MUTE}} = \text{LOW}$	24.1	25.3	26.5	dB
Gain variation with frequency referred to 1kHz	$G_{VDTMF(F)}$	$f = 300\sim 3400\text{Hz}$		± 0.2		dB
Gain variation with temperature referred to 25°C	$G_{VDTMF(T)}$	$T_a = -25 \sim +75\text{ }^\circ\text{C}$		± 0.4		dB
Voltage gain from DTMF to QR (confidence tone)	G_{VCT}	$V_{DTMF} = 20\text{mV (RMS)}$ $R_L = 150\Omega$		-15		dB
Mute function (pin MUTE)						
LOW level input voltage	V_{IL}		V_{EE} -0.4		V_{EE} +0.3	V
HIGH level input voltage	V_{IH}		V_{EE} +1.5		V_{CC} +0.4	V
Input current	$I_{\overline{\text{MUTE}}}$			1.5		μA
Gain reduction for microphone and receiving amplifiers	G_{VTRXM}	$\overline{\text{MUTE}} = \text{LOW}$		80		dB

APPLICATION INFORMATION CIRCUIT

Typical application of the UTC TEA1110A in sets with Pulse Dialling or Flash facilities

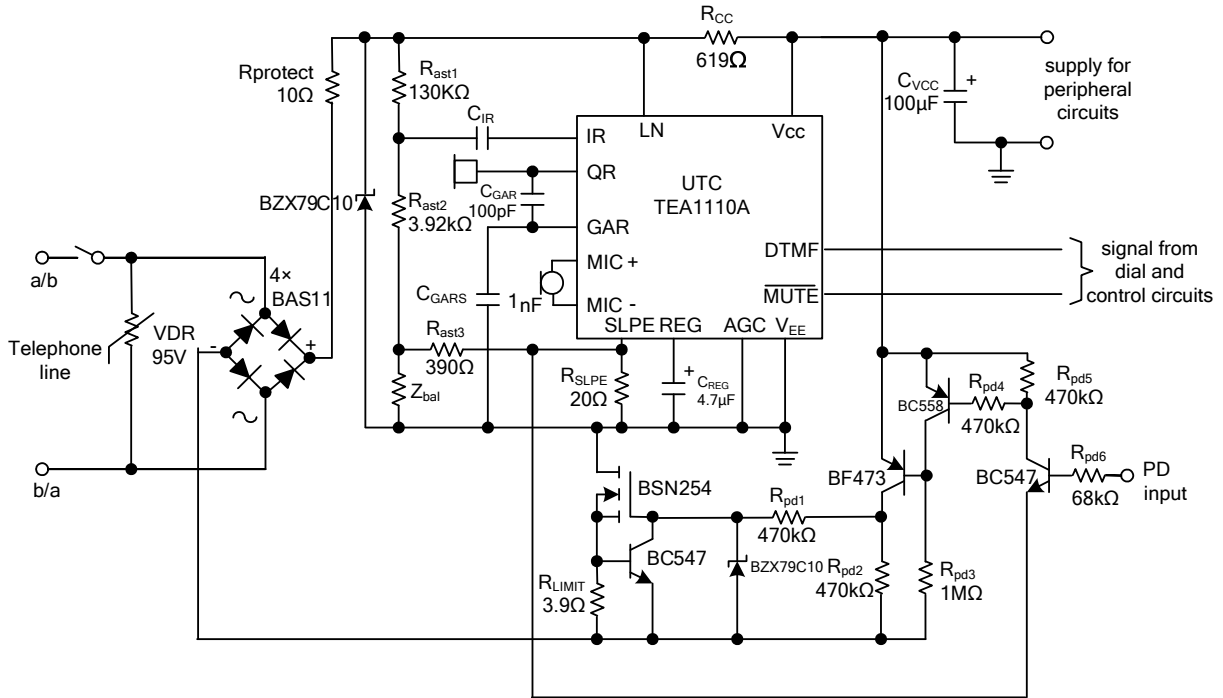

FUNCTIONAL DESCRIPTION

Supply (pins LN, SLPE, VCC and REG)

The UTC **TEA1110A** and its peripheral circuit derive the power supply from telephone line (see Fig.1). The IC generates a stabilized reference voltage (V_{REF}) between pins LN and SLPE. The voltage at pin SLPE is proportional to the line current. V_{REF} is temperature compensated and can be adjusted by means of an external resistor (R_{VA}). V_{REF} is set to 3.35 V, which can be increased by connecting R_{VA} between pins REG and SLPE (see Fig.2) and be decreased by connecting R_{VA} between pins REG and LN. The voltage at pin REG is used by the internal regulator to generate V_{REF} and is decoupled by, which is connected to V_{EE} . This C_{REG} capacitor converted into an equivalent inductance (see Section "Set impedance") realizes the set impedance conversion from its DC value (R_{SLPE}) to its AC value (R_{CC} in the audio-frequency range).

In the following formula, the most appropriate value for R_{SLPE} is 20 Ω . The changing of R_{SLPE} will affect the DC characteristics; furthermore, it can influence the microphone and DTMF gains, the gain control characteristics, the side tone level and the maximum output swing on the line.

The voltage at pin LN is:

$$V_{LN} = V_{REF} + R_{SLPE} \times I_{SLPE}$$

$$I_{SLPE} = I_{LINE} - I_{CC} - I_P - I^*$$

Where: I_{LINE} = line current

I_{CC} = current consumption of the IC

I_P = supply current for peripheral circuits

I^* = current consumed between LN and V_{EE} .

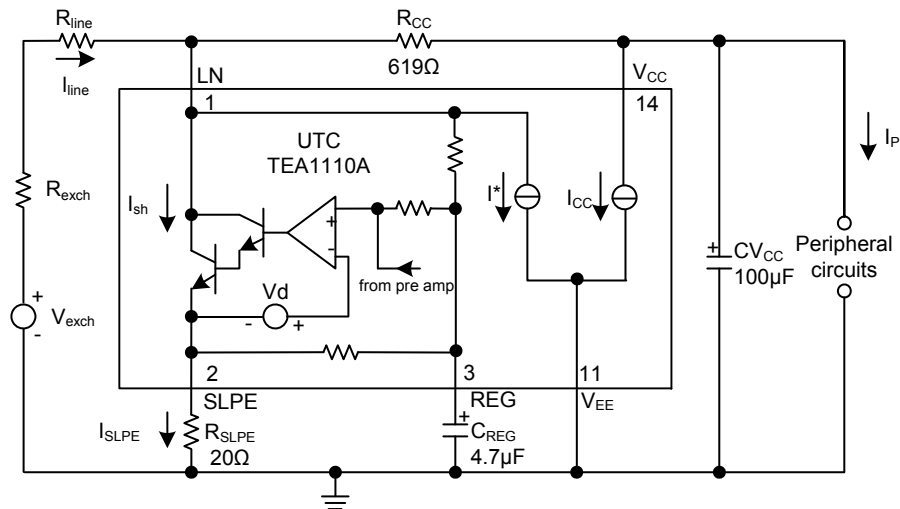
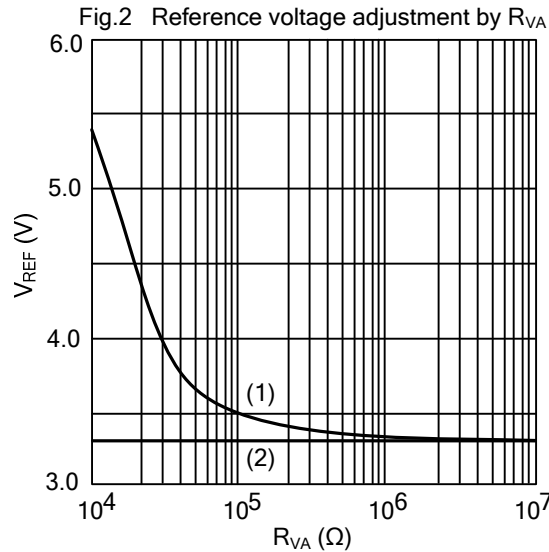

Fig 1. Supply configuration.

FUNCTIONAL DESCRIPTION(Cont.)



(1) Influence of R_{VA} on V_{REF}
 (2) V_{REF} without influence of R_{VA}

The internal circuitry of the UTC **TEA110A** is supplied from pin V_{CC} which can be used to supply peripheral circuits such as dialling or control circuits. This voltage supply is derived from the line voltage by means of a resistor (R_{CC}) and it must be decoupled by a capacitor C_{VCC}. The V_{CC} voltage depends on the current consumed by the IC and the peripheral circuits as shown by the formula : (R_{CCint} is the internal equivalent resistance of the voltage supply, and I_{rec} is the current consumed by the output stage of the earpiece amplifier)

$$V_{CC} = V_{CC0} - R_{CCint} \times (I_p - I_{REC})$$

$$V_{CC0} = V_{LN} - R_{CC} \times I_{CC} \text{ (see also Figs 3 and 4).}$$

The DC line current flowing into the set is determined by the exchange supply voltage (V_{exch}), the feeding bridge resistance (R_{exch}), the DC resistance of the telephone line (R_{line}) and the reference voltage (V_{REF}). The internal reference voltage (generating V_{REF}) would be automatically adjusted to a lower value when the line currents drop below 7.5mA. Therefore, more sets can work in parallel with DC line voltages (excluding the polarity guard) down to 1.6V (absolute minimum voltage). At currents below 7.5mA, the circuit has limited sending and receiving levels. This is called the low voltage area.

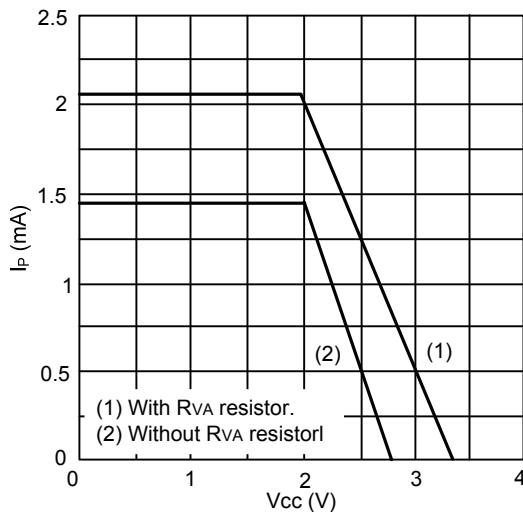

Fig.3 Typical current I_p available from V_{CC} for peripheral circuits at I_{LINE}=15mA.

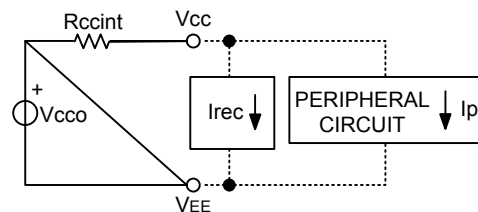
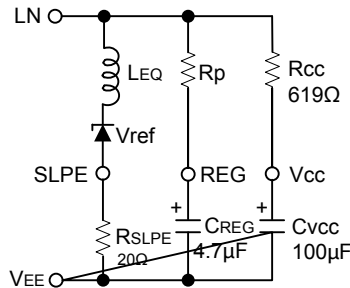

Fig.4 V_{CC} supply voltage for peripherals

FUNCTIONAL DESCRIPTION(Cont.)

Set impedance

The dynamic impedance is mainly determined by the RCC resistor within the audio frequency range. The equivalent impedance of the circuit is shown in Fig.5.



$$LEQ = CREG \times RSLPE \times Rp$$

Rp=internal resistance
Rp=15.5kΩ

Fig.5 Equivalent impedance between LN and VEE

Microphone amplifier (pins MIC+ and MIC-)

The UTC **TEA1110A** has symmetrical microphone inputs. The input impedance between pin MIC+ and pin MIC- is 64kΩ (2 × 32kΩ). On this microphone amplifier, automatic gain control is used for line loss compensation.

Receiving amplifier (pins IR, GAR and QR)

The receiving amplifier has one input (IR) and one output (QR). The input impedance between pin IR and pin VEE is 20kΩ. Connecting an external resistor RGAR between pins GAR and QR can decrease the voltage gain within 14dB from pin IR to pin QR. The two external capacitors CGAR (connected between pins GAR and QR) and CGARS (connected between GAR and VEE) ensure stability, the CGAR capacitor provides a first-order low-pass filter. The cut-off frequency corresponds to the time constant CGAR × (RGARint // RGAR). And the RGARint is the internal resistor connected between pins GAR and QR which sets a 125 kW typ gain. The condition CGARS = 10 × CGAR is required to ensure stability.

The output voltage of the receiving amplifier is for continuous wave drive specially. The maximum output swing depends on the DC line voltage, the RCC resistor, the ICC current consumption of the circuit, the IP current consumption of the peripheral circuits and the load impedance.

On this receiving amplifier automatic gain control is used for line loss compensation.

Automatic gain control (pin AGC)

The UTC **TEA1110A** performs automatic line loss compensation. The automatic gain control varies both the gain of the microphone amplifier and receiving amplifier in accordance with the DC line current within 5.9 dB (which corresponds approximately to a line length of 5 km for a 0.5 mm diameter twisted-pair copper cable with a DC resistance of 176Ω/km and an average attenuation of 1.2dB/km).

The IC can be used with different configurations of feeding bridge (supply voltage and bridge resistance) by the means of connecting an external resistor RAGC between pins AGC and VEE. The line currents ISTART and ISTOP can be increased by this resistor (the ratio between ISTART and ISTOP is not affected by the resistor). When pin AGC is in the open-circuit condition, the AGC function is inactive.

Mute function (pin MUTE MUTE)

The mute function performs the switching between the speech mode and the dialling mode. When the MUTE is in a low level, the DTMF input is active and the microphone and receiving amplifiers inputs are inactive. When the MUTE is in a high level, the microphone and receiving amplifiers inputs are active while the DTMF input is inactive. The input includes a pull-up resistor.

DTMF amplifier (pin DTMF)

When the DTMF amplifier is inactive, dialling tones that can be heard in the earpiece at a low level may be sent on line. The UTC **TEA1110A** has an asymmetrical DTMF input. The input impedance between DTMF and VEE is 20kΩ. The automatic gain control has no effect on the DTMF amplifier.

■ FUNCTIONAL DESCRIPTION(Cont.)

SIDETONE SUPPRESSION

The UTC **TEA1110A** anti-side tone network consisting of R_{CC}/Z_{line} , R_{ast1} , R_{ast2} , R_{ast3} , R_{SLPE} and Z_{bal} (see Fig.6) suppresses the transmitted signal in the earpiece. Maximum compensation is obtained under the following conditions:

$$R_{SLPE} \times R_{ast1} = R_{CC} \times (R_{ast2} + R_{ast3})$$

$$K = \frac{(R_{ast2} \times (R_{ast3} + R_{SLPE}))}{(R_{ast1} \times R_{SLPE})}$$

$$Z_{bal} = k \times Z_{line}$$

The scale factor k is mainly for the compatibility with a standard capacitor from the E6 or E12 range for Z_{bal} .

Z_{line} varies considerably with the line type and the line length in practice. Therefore, the Z_{bal} value should be set to be an average line length which gives appropriate side tone suppression with short and long lines. The suppression also depends on the accuracy of the match between Z_{bal} and the impedance of the average line.

The receiving signal is to be attenuated 32dB by the anti-side tone network from the line before it enters the receiving amplifier, and the attenuation is almost constant over the whole audio frequency range.

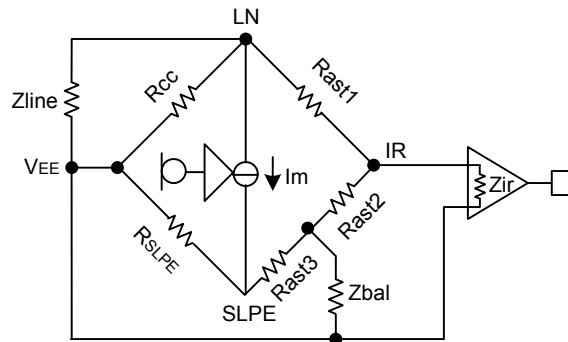

Fig.6 Equivalent circuit of UTC TEA1110A anti-sidetone bridge

UTC assumes no responsibility for equipment failures that result from using products at values that exceed, even momentarily, rated values (such as maximum ratings, operating condition ranges, or other parameters) listed in products specifications of any and all UTC products described or contained herein. UTC products are not designed for use in life support appliances, devices or systems where malfunction of these products can be reasonably expected to result in personal injury. Reproduction in whole or in part is prohibited without the prior written consent of the copyright owner. The information presented in this document does not form part of any quotation or contract, is believed to be accurate and reliable and may be changed without notice.