



75232

LINEAR INTEGRATED CIRCUIT

MULTIPLE RS-232 DRIVERS AND RECEIVERS

DESCRIPTION

The UTC 75232 is a monolithic IC containing three independent drivers and five receivers which comply with the requirements of the TIA/EIA232-F standards.

FEATURES

- * Single chip with easy interconnection of the UART and serial-port connector of personal computer.
- * Meets standard TIA/EIA-232-F and ITU V.28
- * Up to 120 kbps data rate
- * 20-pin SOP/ DIP/SSOP/TSSOP packages

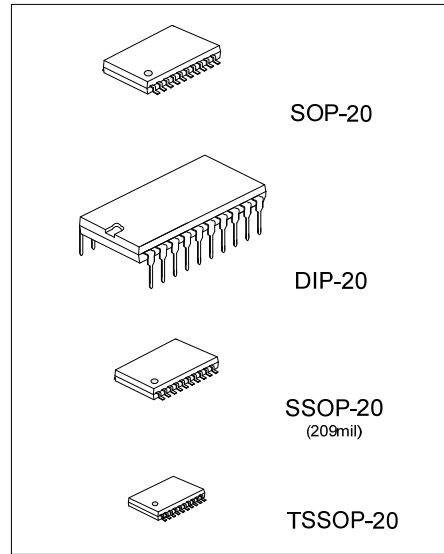

Lead-free: 75232L
Halogen-free: 75232G

ORDERING INFORMATION

Ordering Number			Package	Packing
Normal	Lead Free	Halogen Free		
75232-D20-T	75232L-D20-T	75232G-D20-T	DIP-20	Tube
75232-P20-R	75232L-P20-R	75232G-P20-R	TSSOP-20	Tape Reel
75232-P20-T	75232L-P20-T	75232G-P20-T	TSSOP-20	Tube
75232-R20-R	75232L-R20-R	75232G-R20-R	SSOP-20	Tape Reel
75232-R20-T	75232L-R20-T	75232G-R20-T	SSOP-20	Tube
75232-S20-R	75232L-S20-R	75232G-S20-R	SOP-20	Tape Reel
75232-S20-T	75232L-S20-T	75232G-S20-T	SOP-20	Tube

<p>75232L-D20-T</p> <p>(1)Packing Type (2)Package Type (3)Lead Plating</p>	<p>(1) R: Tape Reel, T: Tube (2) D20: DIP-20, S20: SOP-20, R20: SSOP-20, P20: TSSOP-20 (3) G: Halogen Free, L: Lead Free, Blank: Pb/Sn</p>
--	--

■ PIN CONFIGURATION

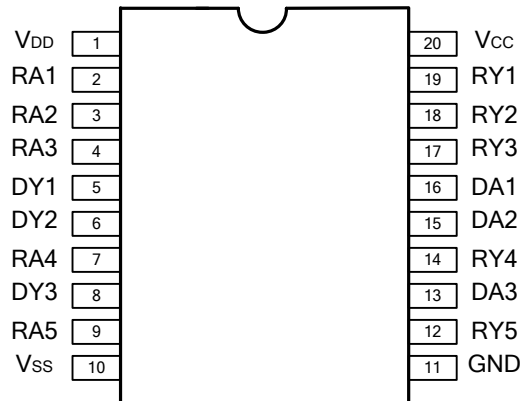

■ PIN DESCRIPTION

PIN NO.	PIN NAME	FUNCTION
1	V _{DD}	Supply voltage
2	RA1	First receiver input
3	RA2	Second receiver input
4	RA3	Third receiver input
5	DY1	First driver output
6	DY2	Second driver output
7	RA4	Fourth receiver input
8	DY3	Third driver output
9	RA5	Fifth receiver input
10	V _{SS}	Supply voltage
11	GND	Ground
12	RY5	Fifth receiver output
13	DA3	Third driver input
14	RY4	Fourth receiver output
15	DA2	Second driver input
16	DA1	First driver input
17	RY3	Third receiver output
18	RY2	Second receiver output
19	RY1	First receiver output
20	V _{CC}	Supply voltage

■ ABSOLUTE MAXIMUM RATINGS

PARAMETER		SYMBOL	RATINGS	UNIT
Supply Voltage (Note 2)		V_{DD}	15	V
		V_{SS}	-15	V
		V_{CC}	10	V
Input Voltage Range	Driver	V_{IN}	-15 ~ 7	V
	Receiver		-30 ~ 30	V
Driver Output Voltage Range		V_{OUT}	-15 ~ 15	V
Receiver Low Level Output Current		I_{OUT}	20	mA
Operation Temperature		T_{OPR}	0 ~ +70	°C
Storage Temperature		T_{STG}	-40 ~ +150	°C

Note: 1. Absolute maximum ratings are those values beyond which the device could be permanently damaged.

Absolute maximum ratings are stress ratings only and functional device operation is not implied.

2. All voltages are with respect to the network ground terminal.

■ THERMAL DATA

PARAMETER		SYMBOL	RATINGS	UNIT
Junction-to-Ambient	DIP-20	θ_{JA}	70	°C/W
	SOP-20		100	
	SSOP-20		115	
	TSSOP-20		115	

■ RECOMMENDED OPERATING RATINGS

PARAMETER		SYMBOL	MIN	TYP	MAX	UNIT
Supply Voltage		V_{DD}	7.5	9	15	V
		V_{SS}	-7.5	-9	-15	V
		V_{CC}	4.5	5	5.5	V
Level Input Voltage (driver only)	High	V_{IH}	1.9			V
	Low	V_{IL}			0.8	V
High Level Output Current	Driver	I_{OH}			-6.0	mA
	Receiver				-0.5	
Low Level Output Current	Driver	I_{OL}			6	mA
	Receiver				16	

■ ELECTRICAL CHARACTERISTICS

(Over recommended supply voltage and operating temperature ranges, unless otherwise specified)

PARAMETER	SYMBOL	TEST CONDITIONS	MIN	TYP	MAX	UNIT	
SUPPLY CURRENTS							
Supply Current from V_{DD}	I_{DD}	No load. All inputs at 1.9V	$V_{DD}=9V, V_{SS}=-9V$			15	mA
			$V_{DD}=12, V_{SS}=-12V$			19	
			$V_{DD}=15, V_{SS}=-15V$			25	
		No load. All inputs at 0.8V	$V_{DD}=9V, V_{SS}=-9V$			4.5	mA
			$V_{DD}=12, V_{SS}=-12V$			5.5	
			$V_{DD}=15, V_{SS}=-15V$			9	
Supply Current from V_{SS}	I_{SS}	No load. All inputs at 1.9V	$V_{DD}=9V, V_{SS}=-9V$			-15	mA
			$V_{DD}=12, V_{SS}=-12V$			-19	
			$V_{DD}=15, V_{SS}=-15V$			-25	
		No load. All inputs at 0.8V	$V_{DD}=9V, V_{SS}=-9V$			-3.2	mA
			$V_{DD}=12, V_{SS}=-12V$			-3.2	
			$V_{DD}=15, V_{SS}=-15V$			-3.2	
Supply Current from V_{CC}	I_{CC}	No load. All inputs at 5V, $V_{CC}=5V$			30	mA	

■ ELECTRICAL CHARACTERISTICS(Cont.)

PARAMETER	SYMBOL	TEST CONDITIONS	MIN	TYP	MAX	UNIT		
DRIVER SECTION ($V_{DD}=9V$, $V_{SS}=-9V$, $V_{CC}=5V$)								
Output Voltage Level (Figure. 1)	High	V_{OH}	$V_{IL}=0.8V$, $R_L=3\text{ k}\Omega$	6	7.5		V	
	Low	V_{OL}	$V_{IH}=1.9V$, $R_L=3\text{ k}\Omega$ (Note 1)		-7.5	-6	V	
Input Current Level (Figure. 2)	High	I_{IH}	$V_{IN}=5V$			10	μA	
	Low	I_{IL}	$V_{IN}=0V$			-1.6	mA	
Short Circuit Output Current (Figure. 1)	High	$I_{OH(SC)}$	$V_{IL}=0.8V$, $V_{OUT}=0V$ (Note 2)	-8.5	-12	-19.5	mA	
	Low	$I_{OL(SC)}$	$V_{IH}=2.0V$, $V_{OUT}=0V$	8.5	12	19.5	mA	
Output Resistance (Note 3)		R_{OUT}	$V_{DD}=V_{SS}=V_{CC}=0V$, $V_{OUT}=-2V\sim 2V$	300			Ω	
RECEIVER SECTION ($V_{DD}=9V$, $V_{SS}=-9V$, $V_{CC}=5V$)								
Going Threshold Voltage	Positive	V_{T+}	$T_a=25^\circ C$ (Figure. 5)	1.75	1.9	2.3	V	
	Negative	V_{T-}	$T_a=0^\circ C \sim 70^\circ C$ (Figure. 5)	1.55		2.3		
Input Hysteresis($V_{T+} - V_{T-}$)		V_{HYS}		0.5			V	
Output Voltage Level	High	V_{OH}	$I_{OH}=-0.5mA$	$V_{IH}=0.75V$	2.6	4	5	V
	Low	V_{OL}	$V_{IN}=3V$, $I_{OL}=10mA$	Inputs Open	2.6			
Input Current Level (Figure. 5)	High	I_{IH}	$V_{IN}=25V$	3.6		8.3	mA	
			$V_{IN}=3V$	0.43				
	Low	I_{IL}	$V_{IN}=-25V$	-3.6		-8.3	mA	
			$V_{IN}=-3V$	-0.43				
Short-Circuit Output Current		$I_{O(SC)}$	(Fig. 4)		-3.4	-12	mA	

Note. 1. For voltage logic levels, the more positive (less negative) limit is designated as maximum, (e.g. if -10V is a maximum, the typical value is a more negative voltage).

2: Output short circuit conditions must maintain the total power dissipation below absolute maximum ratings and the sign is used to indicate direction.

3: Test conditions are those specified by TIA/EIA232-F and as listed above.

■ SWITCHING CHARACTERISTICS ($T_a=25^\circ C$)

PARAMETER	SYMBOL	TEST CONDITIONS	MIN	TYP	MAX	UNIT
DRIVER SECTION ($V_{DD}=12V$, $V_{SS}=-12V$, $V_{CC}=5V$)						
Propagation Delay Time	t_{PLH}	$R_L=3 \sim 7\text{ k}\Omega$, $C_L=15pF$		315	500	ns
	t_{PHL}	(Figure. 3)		75	175	ns
Transition Time	t_{TLH}	$R_L=3 \sim 7\text{ k}\Omega$, $C_L=15pF$		60	100	ns
	t_{THL}			40	75	ns
	t_{TLH}	$R_L=3 \sim 7\text{ k}\Omega$, $C_L=2500pF$		1.7	2.5	μs
	t_{THL}		(Figure. 3, Note)		1.5	2.5
RECEIVER SECTION ($V_{DD}=12V$, $V_{SS}=-12V$, $V_{CC}=5V$)						
Propagation Delay Time (Figure. 6)	t_{PLH}	$R_L=5\text{ k}\Omega$, $C_L=50pF$		107	250	ns
	t_{PHL}			42	150	ns
	t_{PLH}	$R_L=1.5\text{ k}\Omega$, $C_L=15pF$		100	160	ns
	t_{PHL}			60	100	ns
Transition Time (Figure. 6)	t_{TLH}	$R_L=5\text{ k}\Omega$, $C_L=50pF$		175	350	ns
	t_{THL}			16	60	ns
	t_{TLH}	$R_L=1.5\text{ k}\Omega$, $C_L=15pF$		90	175	ns
	t_{THL}			15	50	ns

Note: Measured points of the output waveform (TIA/EIA-232-F conditions) as below, all unused inputs are tied.

- Low to High level: between -3V and 3V.

- High to Low level: between 3V and -3V.

PARAMETER MEASUREMENT INFORMATION

DRIVER TEST CIRCUITS:

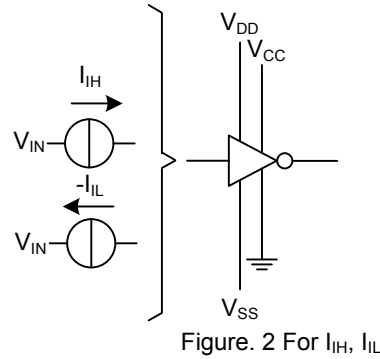
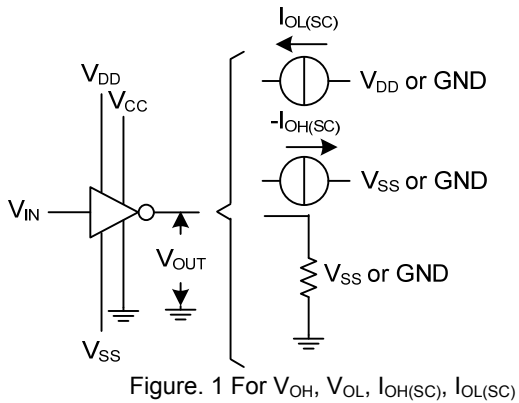

DRIVER VOLTAGE WAVEFORMS:

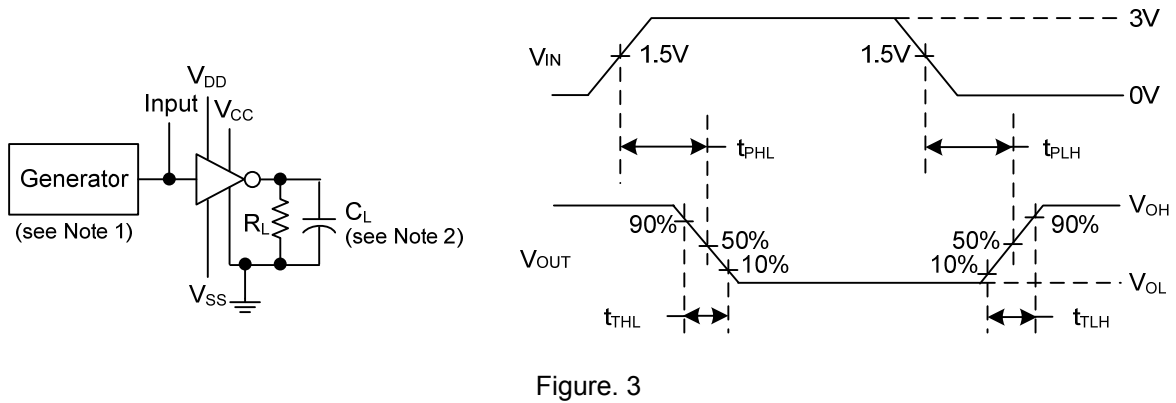

Note: 1. The pulse generator characteristics: $t_w=25\mu s$, $PRR=20kHz$, $Z_o=50\Omega$, $t_r=t_f<50ns$.
 2. C_L includes probe and jig capacitance.

PARAMETER MEASUREMENT INFORMATION (Cont.)

RECEIVER TEST CIRCUITS:

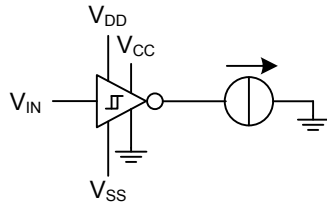

Figure 4. $I_{0(sc)}$

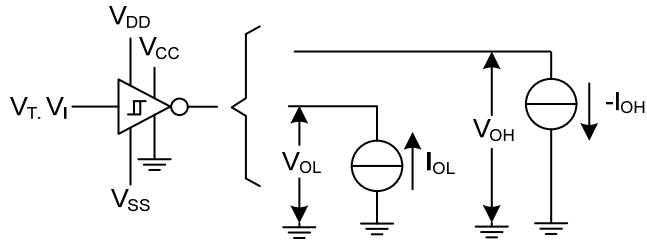

Figure 5 V_T, V_{OH}, V_{OL}

RECEIVER PROPAGATION AND TRANSITION TIMES:

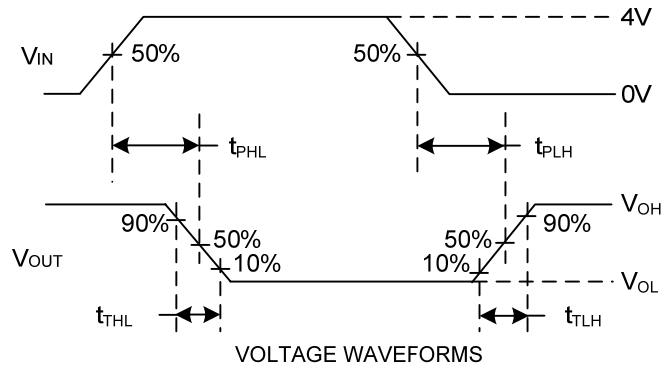
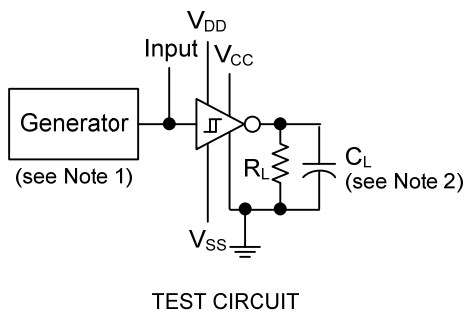

Figure 6.

Note: 1. The pulse generator characteristics: $t_w=25\mu s$, $PRR=20kHz$, $Z_o=50\Omega$, $t_r=t_f<50ns$.
 2. C_L includes probe and jig capacitance.

APPLICATION INFORMATION

Power-Supply protection to meet Power-Off fault conditions of TIA/EIA-232-F

Diodes placed in series with the V_{DD} and V_{SS} leads protect the device in the fault condition in which the device outputs are shorted to $\pm 15V$ and the power supplies are at low and provide low-impedance paths to ground.

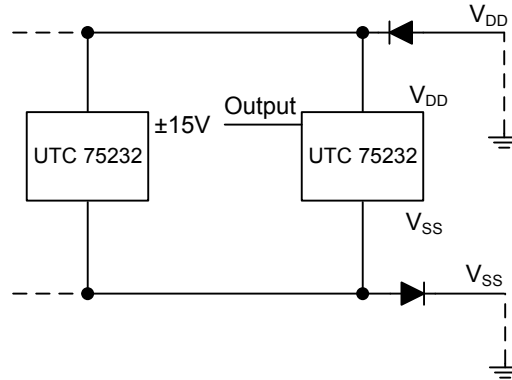

Typical Connection

“*”: Refer Figure 10 to select the correct values for the loading capacitors (C1, C2, and C3), which are required to meet the RS-232 maximum slew-rate requirement of $30V/\mu s$. The value of the loading capacitors required depends upon the line length and desired slew rate, but typically is 330 pF.

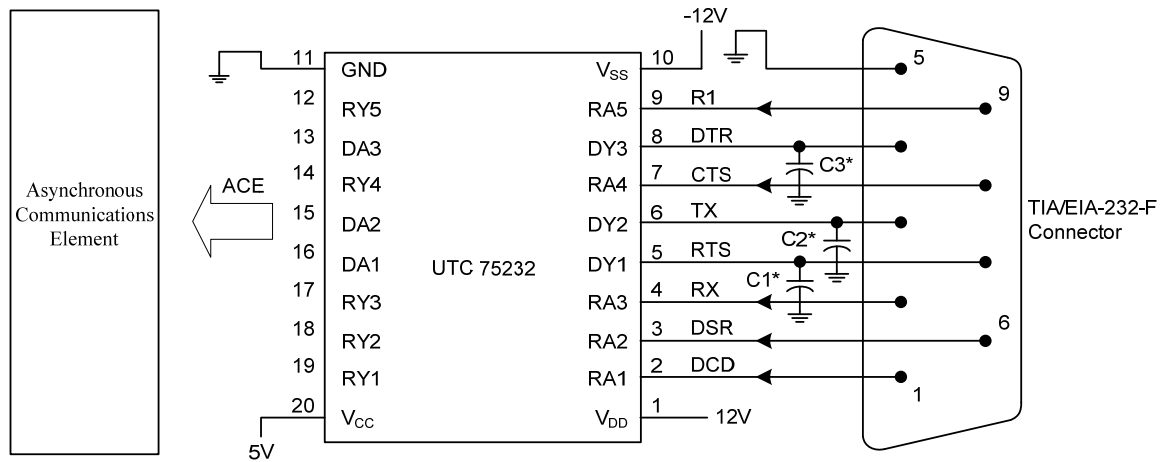

LOGIC SYMBOL AND LOGIC DIAGRAM

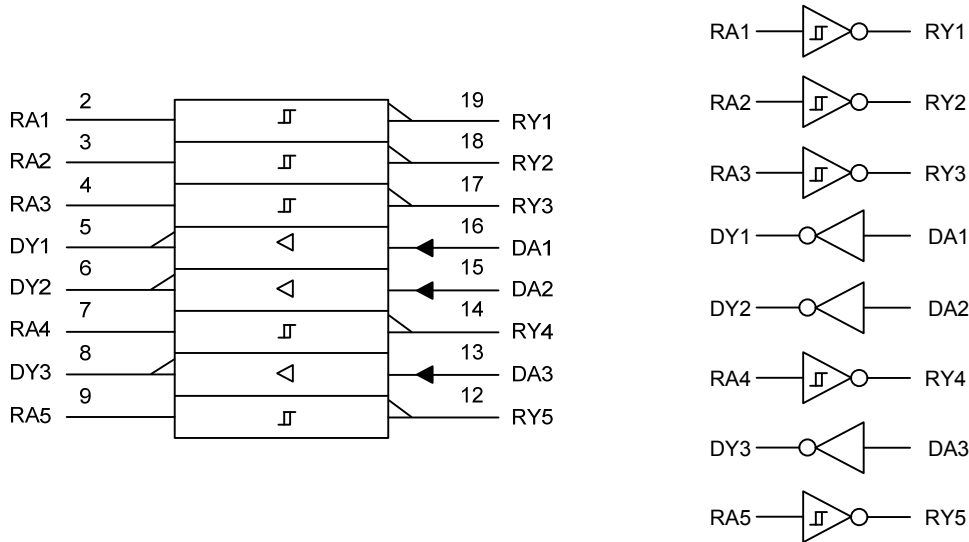

CIRCUIT OF DRIVERS (Resistor value shown are nominal.)

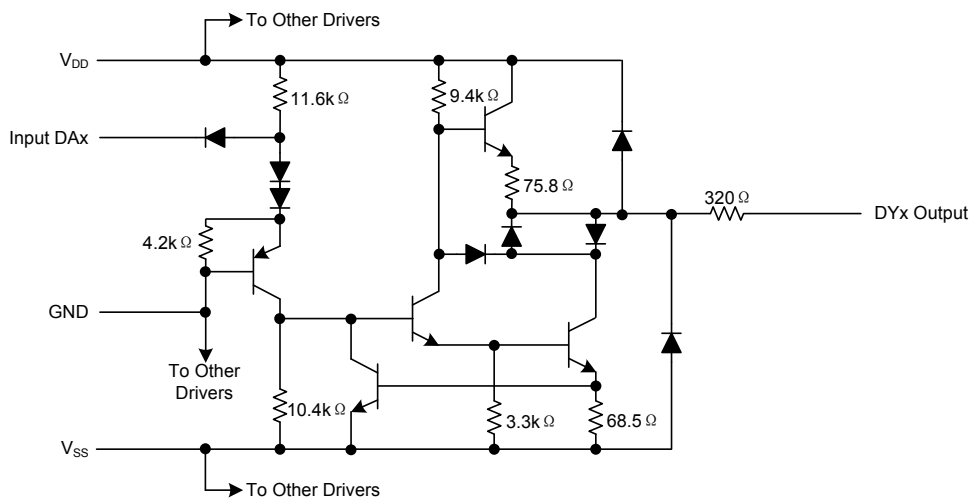

CIRCUIT OF EACH RECEIVER (Resistor value shown are nominal.)

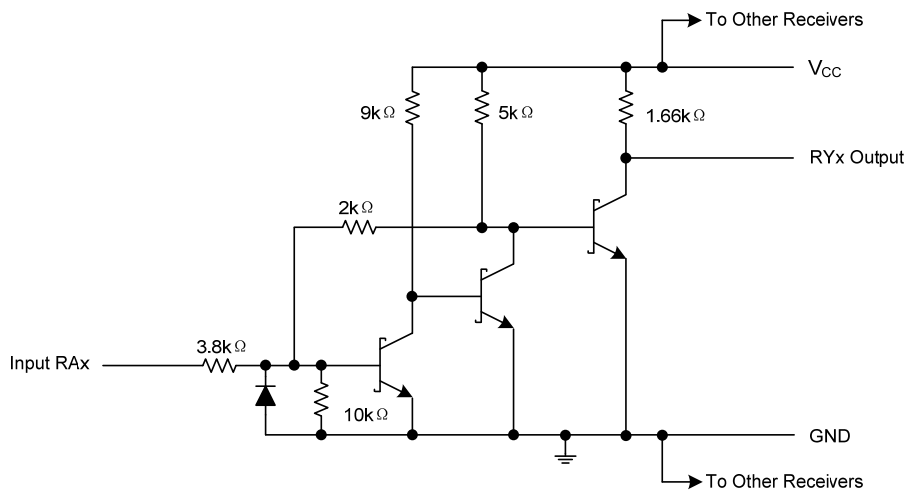

■ TYPICAL CHARACTERISTICS(DRIVER)

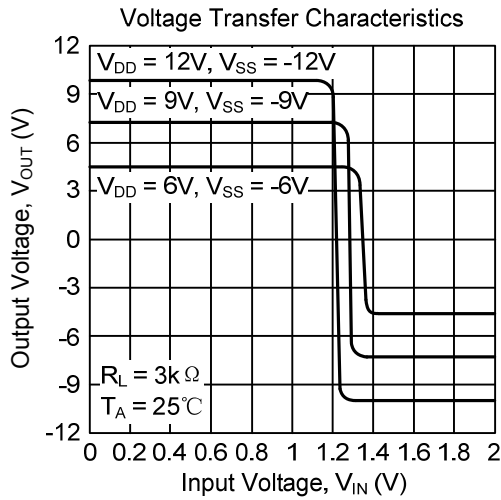

Figure 7

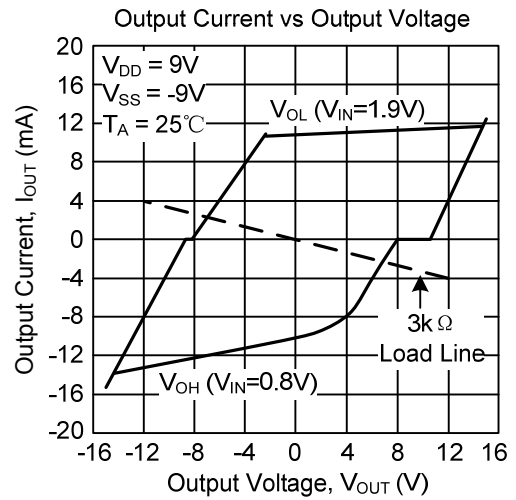

Figure 8

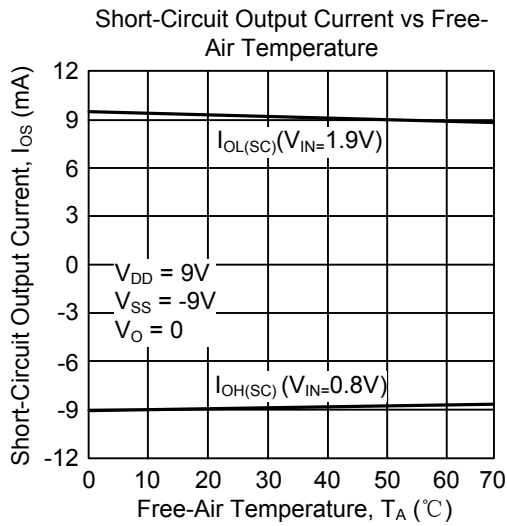

Figure 9

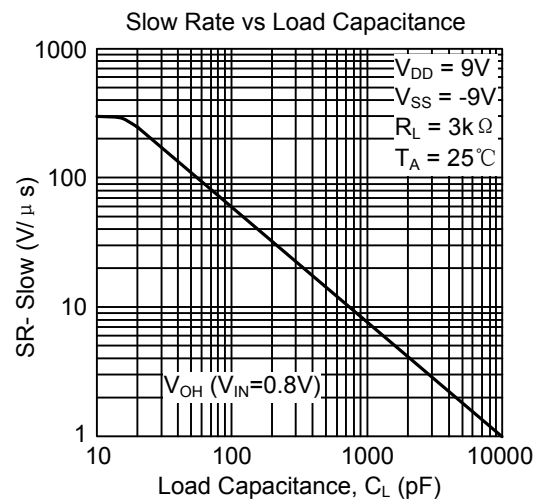

Figure 10

■ TYPICAL CHARACTERISTICS(RECEIVER)

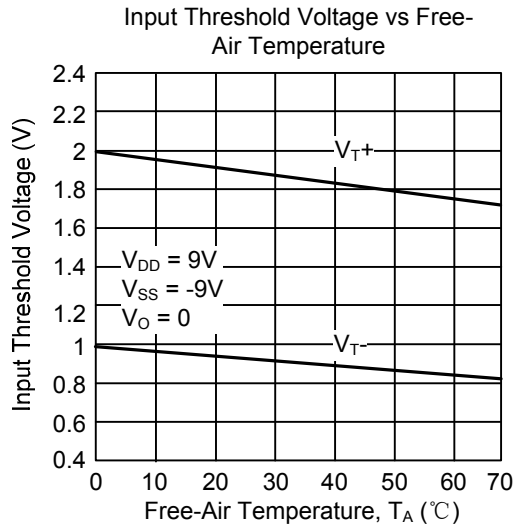

Figure 11

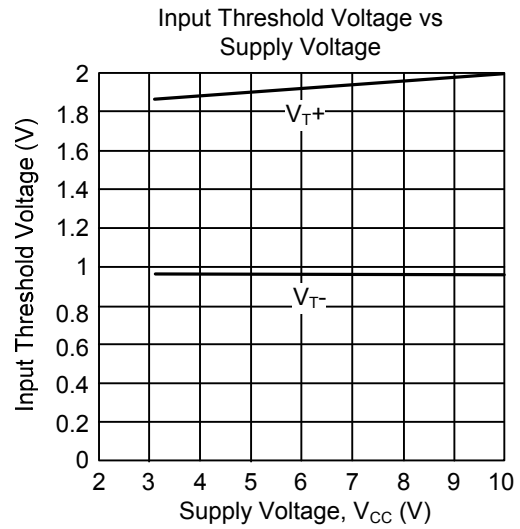

Figure 12

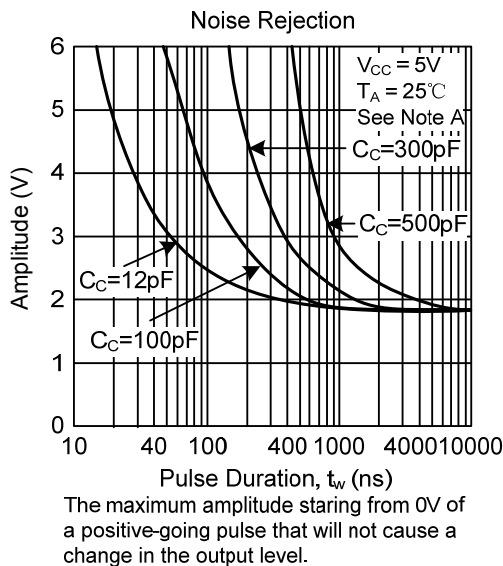

Figure 13

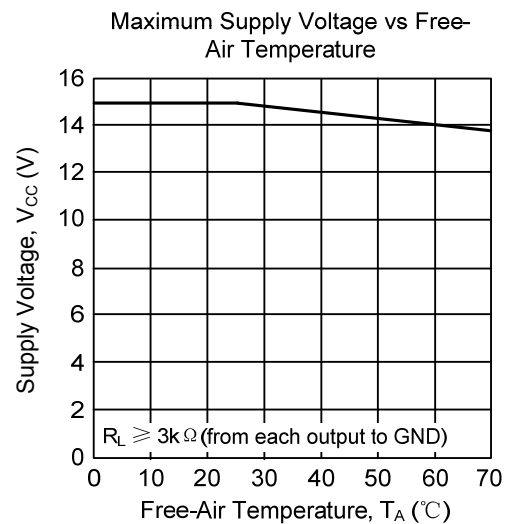

Figure 14

UTC assumes no responsibility for equipment failures that result from using products at values that exceed, even momentarily, rated values (such as maximum ratings, operating condition ranges, or other parameters) listed in products specifications of any and all UTC products described or contained herein. UTC products are not designed for use in life support appliances, devices or systems where malfunction of these products can be reasonably expected to result in personal injury. Reproduction in whole or in part is prohibited without the prior written consent of the copyright owner. The information presented in this document does not form part of any quotation or contract, is believed to be accurate and reliable and may be changed without notice.