



UT912E

CMOS IC

ENCODER FOR REMOTE CONTROLLER

DESCRIPTION

The UTC **UT912E** of CMOS LSIs for remote control system applications is capable of encoding information which consists of N address bits and 12-N data bits. Each address/data input can be set to one of the two logic states. The programmed addresses/data are transmitted together with the header bits by a RF or an infrared transmission medium upon receipt of a trigger signal.

FEATURES

- * Operating voltage: 2.4V ~ 12V
- * Low power and high noise immunity CMOS technology
- * Low standby current (**0.1 μ A** (typ.) at $V_{DD}=5V$)
- * Minimum transmission word (Four words)
- * Built-in oscillator needs only 5% resistor
- * Data code has positive polarity
- * Minimal external components

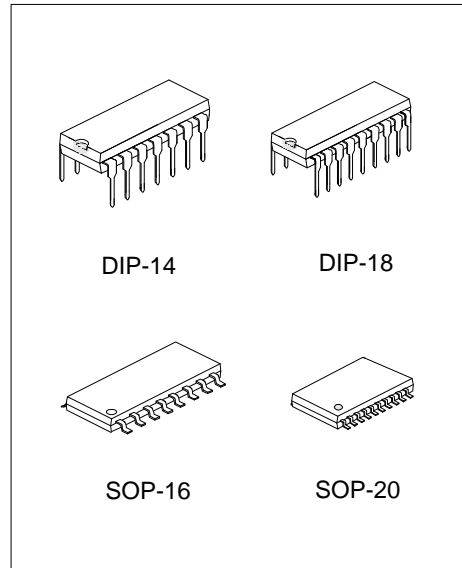

*Pb-free plating product number: UT912EL

ORDERING INFORMATION

Ordering Number		Package	Packing
Normal	Lead Free Plating		
UT912E-D14-T	UT912EL-D14-T	DIP-14	Tube
UT912E-D18-T	UT912EL-D18-T	DIP-18	Tube
UT912E-S16-T	UT912EL-S16-T	SOP-16	Tube
UT912E-S16-R	UT912EL-S16-R	SOP-16	Tape Reel
UT912E-S20-T	UT912EL-S20-T	SOP-20	Tube
UT912E-S20-R	UT912EL-S20-R	SOP-20	Tape Reel

■ PIN CONFIGURATION

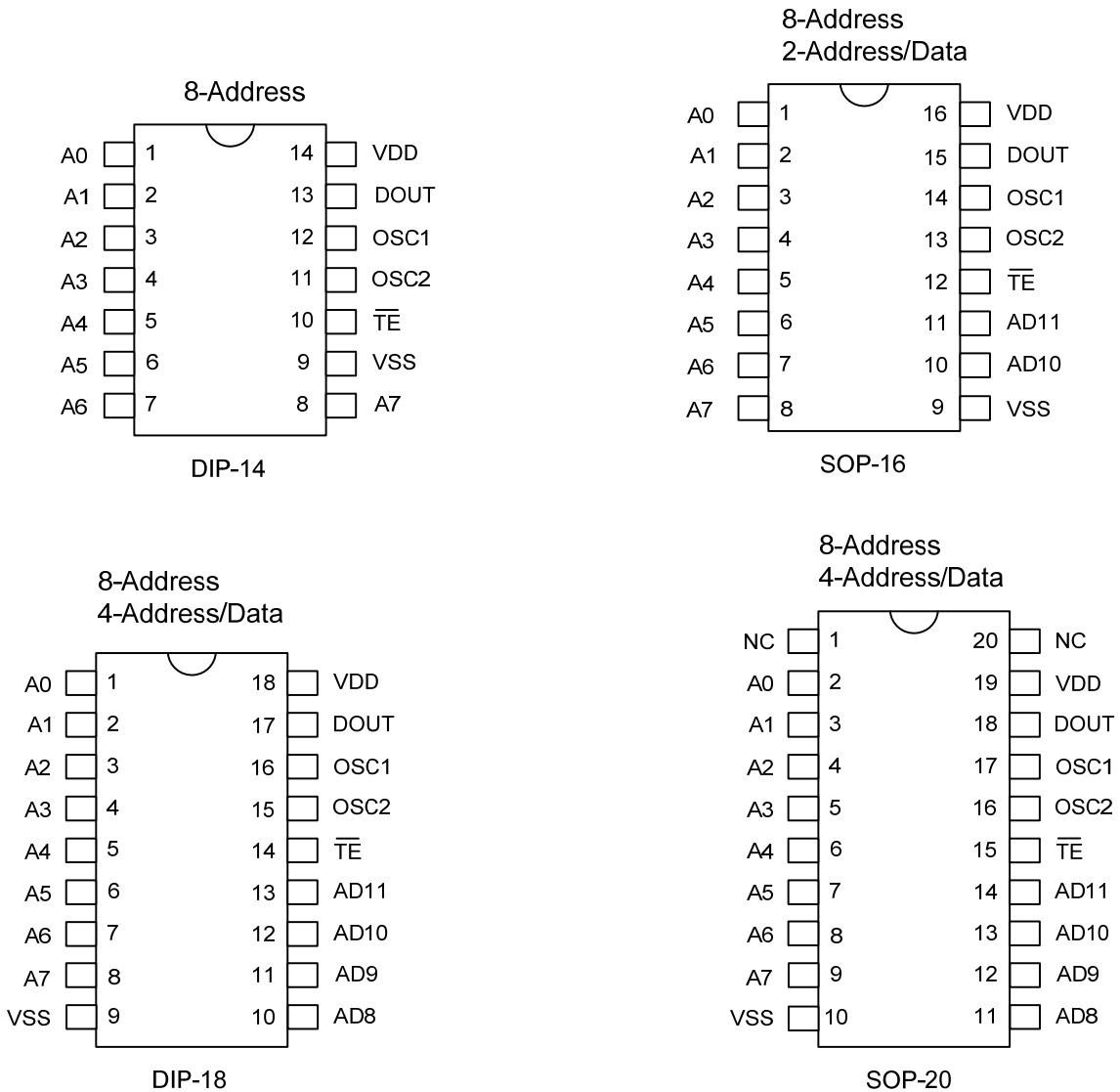

■ PIN DESCRIPTION

PIN NAME	I/O	INTERNAL CONNECTION	DESCRIPTION
A0 ~ A7	I	NMOS TRANSMISSION GATE PROTECTION DIODE	Input pins for address A0 ~ A7 setting These pins can be externally set to VSS or left open
AD8 ~ AD11	I	NMOS TRANSMISSION GATE PROTECTION DIODE	Input pins for address/data AD8 ~ AD11 setting These pins can be externally set to VSS or left open
DOUT	O	CMOS OUT	Encoder data serial transmission output
\overline{TE}	I	CMOS IN Pull-high	Transmission enable, active low
OSC1	I	OSCILLATOR 1	Oscillator input pin
OSC2	O	OSCILLATOR 1	Oscillator output pin
V _{SS}	I		Negative power supply (GND)
V _{DD}	I		Positive power supply

■ BLOCK DIAGRAM

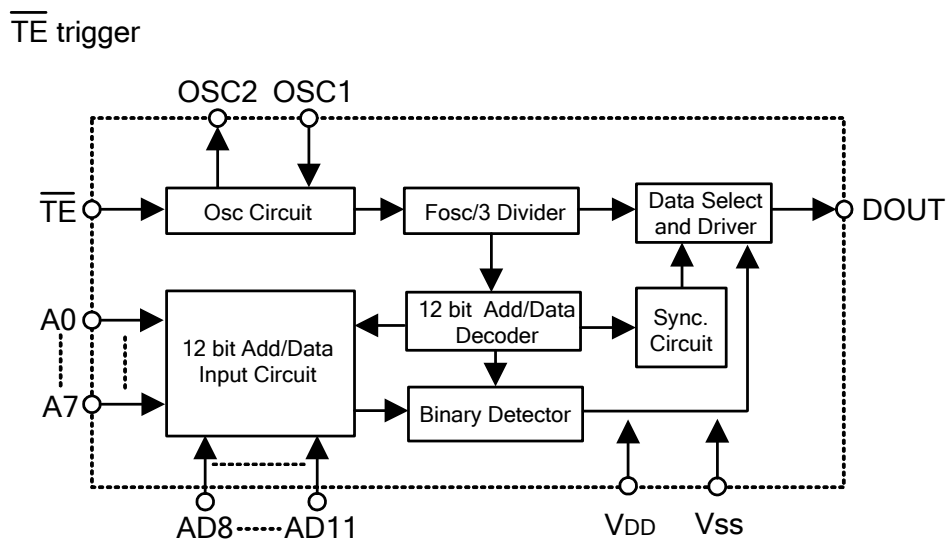

■ ABSOLUTE MAXIMUM RATINGS (Ta=25°C)

PARAMETER	SYMBOL	RATINGS	UNIT
Supply Voltage	V _{DD}	-0.3 ~ +13	V
Input Voltage	V _{IN}	V _{SS} -0.3 ~ V _{DD} +0.3	V
Operating Temperature	T _{OPR}	-20 ~ +85	°C
Storage Temperature	T _{STG}	-40 ~ +150	°C

■ ELECTRICAL CHARACTERISTICS (Ta=25°C, unless otherwise specified.)

PARAMETER	SYMBOL	TEST CONDITIONS	MIN	TYP	MAX	UNIT
Operating Voltage	V _{DD}		2.4	5	12	V
Standby Current	I _{STN-BY}	Oscillator stops	V _{DD} =3V	0.1	1	μA
			V _{DD} =12V	2	4	
Operating Current	I _{OPR}	No load, F _{OSC} =3kHz	V _{DD} =3V	40	80	μA
			V _{DD} =12V	150	300	
Output Driver Current	I _{DOUT}	V _{DD} =5V	V _{OH} =0.9V _{DD} (Source)	-1	-1.6	mA
			V _{OL} =0.1V _{DD} (Sink)	1	1.6	
Input Voltage	High	V _{IH}	0.8V _{DD}		V _{DD}	V
	Low	V _{IL}	0		0.2V _{DD}	V
Oscillator Frequency	f _{OSC}	R _{OSC} =1.1MΩ, V _{DD} =5V		3		kHz
\overline{TE} Pull-high Resistance	R _{TE}	V _{TE} =0V, V _{DD} =5V		1.5	3	MΩ

■ OPERATION FLOWCHART

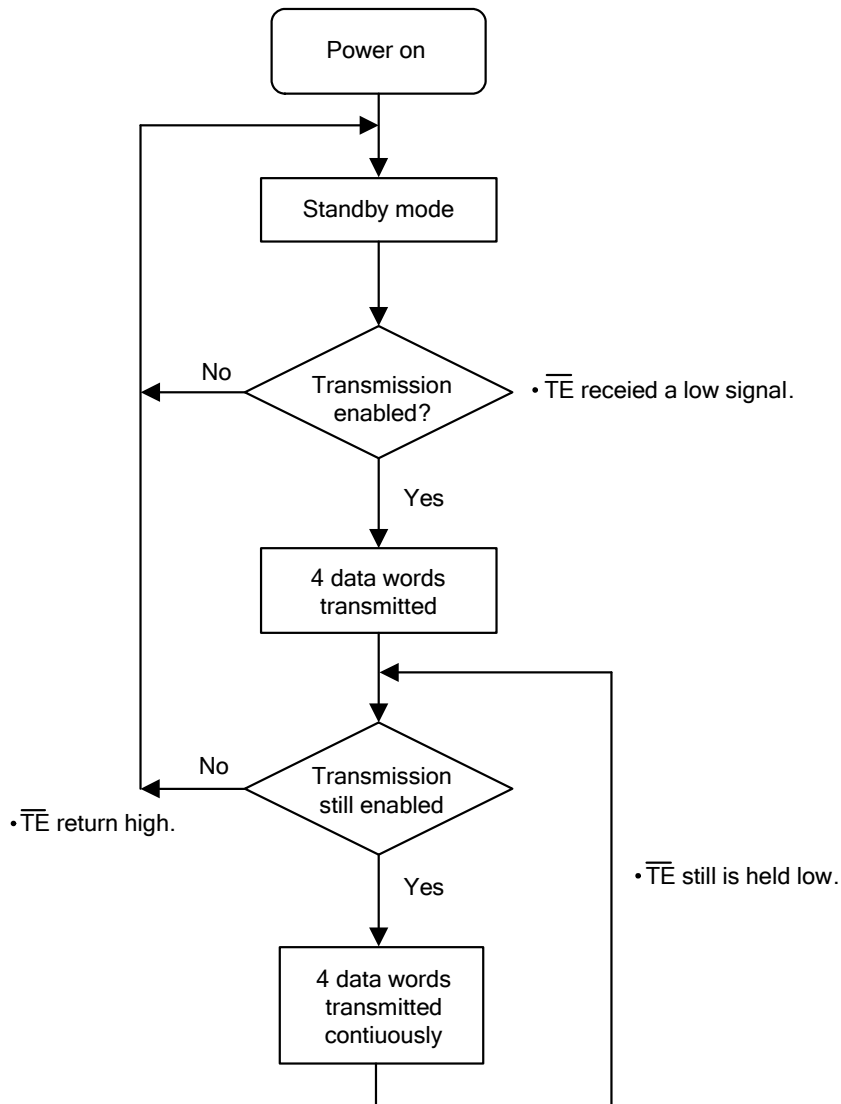

FUNCTIONAL DESCRIPTION

Operation

The UTC **UT912E** start a cycle of 4-words transmission upon receipt of a transmission enable (\overline{TE}). A completed cycle is showed as below. This cycle will repeat itself as long as the transmission enable is held low. While the transmission enable returns high the encoder output completes its final cycle and then stops.

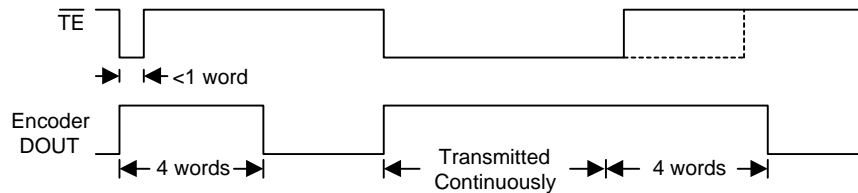

Address/data bit waveform

Each programmable address/data pin can be externally set to one of the following two logic states as shown below.

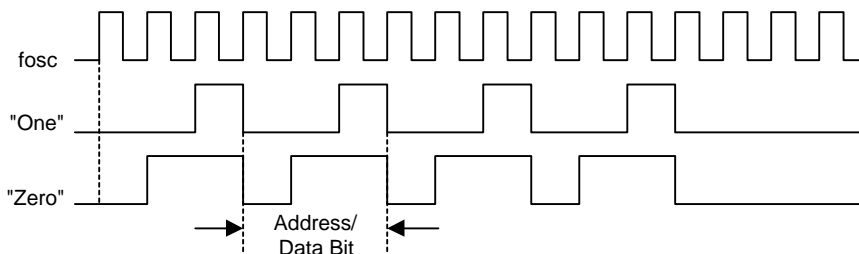

Address/data programming (preset)

The status of each address/data pin can be individually pre-set to logic "high" or "low". If a transmission-enable signal is applied, the encoder scans and transmits the status of the 12 bits of address/data serially in the order A0 to AD11. During information transmission these bits are transmitted with a preceding synchronization bit. If the trigger signal is not applied, the chip enters the standby mode and consumes a reduced current of less than $1 \mu A$ for a supply voltage of 5V.

The following figure shows an application using the UTC **UT912E**:

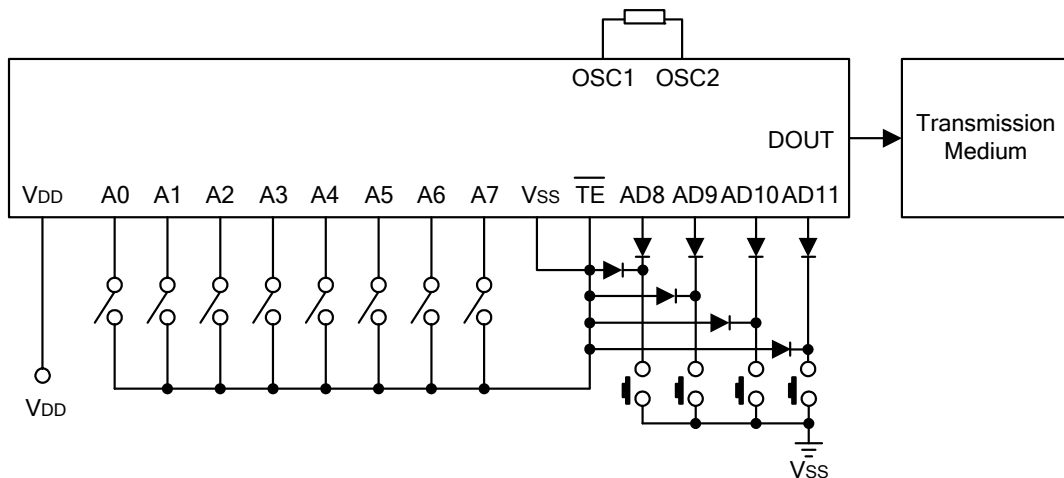

Transmitted information:

Pilot & Sync.	A0	A1	A2	A3	A4	A5	A6	A7	AD8	AD9	AD10	AD11
	1	0	1	0	0	0	1	1	1	1	1	0

Address/Data sequence

The following provides the address/data sequence table for various models of the UTC UT912E encoders. The correct device should be selected according to the individual address and data requirements.

Bits	0	1	2	3	4	5	6	7	8	9	10	11
Address/ Date	A0	A1	A2	A3	A4	A5	A6	A7	AD8	AD9	AD10	AD11

TYPICAL APPLICATION CIRCUIT

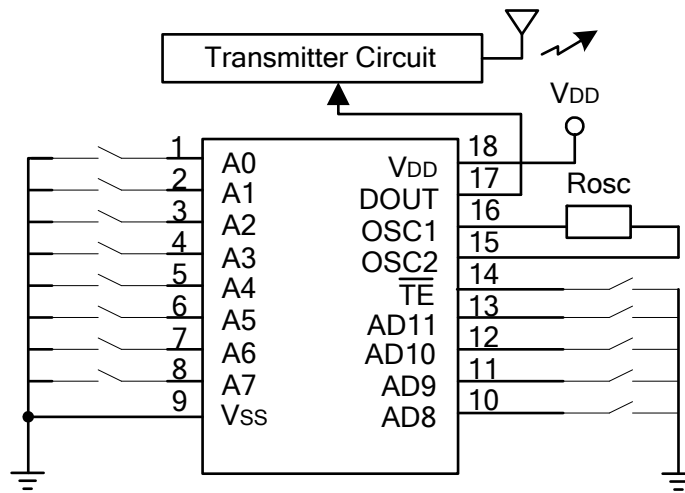

APPROXIMATE INTERNAL CONNECTIONS

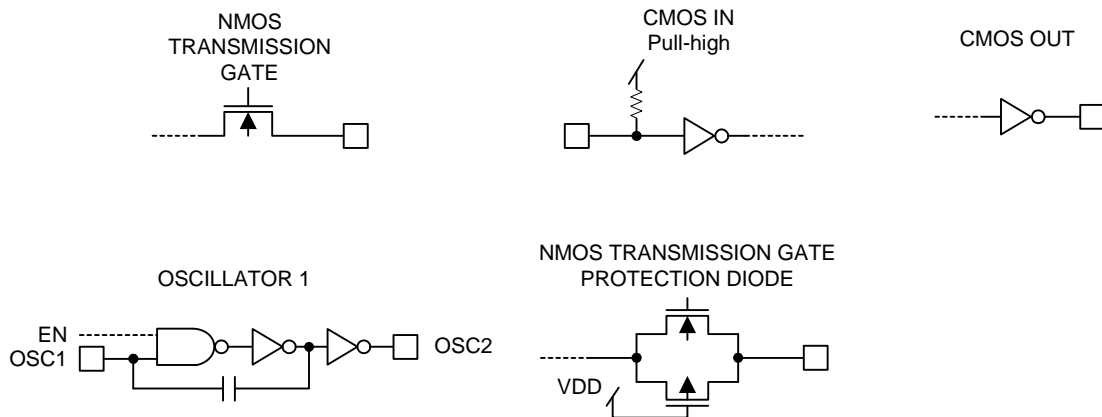

■ OSCILLATOR FREQUENCY VS SUPPLY VOLTAGE

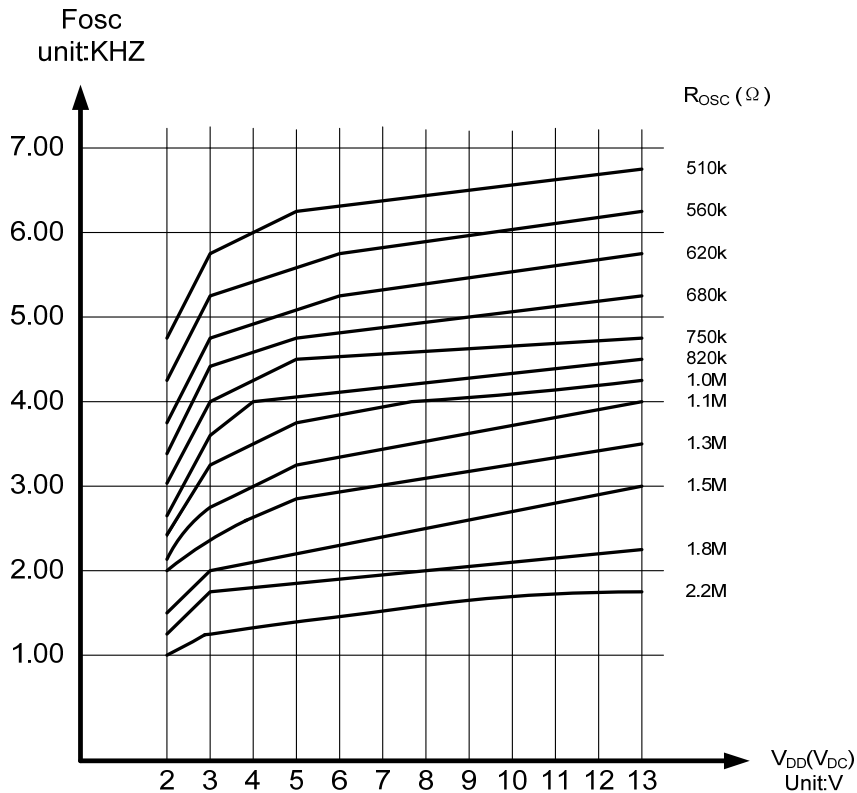

The recommended oscillator frequency is $f_{OSCD} \text{ (decoder)} \cong 50f_{OSCE} \text{ (UT912E encoder)}$

UTC assumes no responsibility for equipment failures that result from using products at values that exceed, even momentarily, rated values (such as maximum ratings, operating condition ranges, or other parameters) listed in products specifications of any and all UTC products described or contained herein. UTC products are not designed for use in life support appliances, devices or systems where malfunction of these products can be reasonably expected to result in personal injury. Reproduction in whole or in part is prohibited without the prior written consent of the copyright owner. The information presented in this document does not form part of any quotation or contract, is believed to be accurate and reliable and may be changed without notice.