

**Decoder For Remote Controller
With Five Functions**

DESCRIPTION

The chip can be used with the encoder RCT02 to provide a complete control functions to the remote-controlled toy. The RCR02 has five output pins corresponding with the five function actions i.e, forward, backward, rightward, leftward and turbo. The received signals are amplified by the three-stage amplifier, and then the appropriate amplified signals are sampled, fault-tolerantly checked and decoded to control the actions of the remote-controlled toy.

There is an internal oscillator in the RCR02. By adding an external resistor conveniently, the oscillator will be constructed. The oscillator frequency can be adjusted by the external resistor. The relative error between the frequencies of the two on chip oscillators in the RCT02 and RCR02 must be less than $\pm 25\%$.

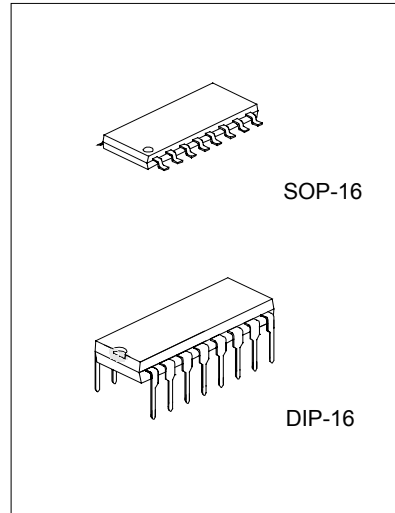

FEATURES

- *Five output pins for control functions
- *Operating power-supply voltage range: 2.5 to 5.0V
- *On-chip reversing amplifiers
- *On-chip oscillator with an external resistor
- *Low operating current
- *Few external components needed

LOGIC BLOCK DIAGRAM

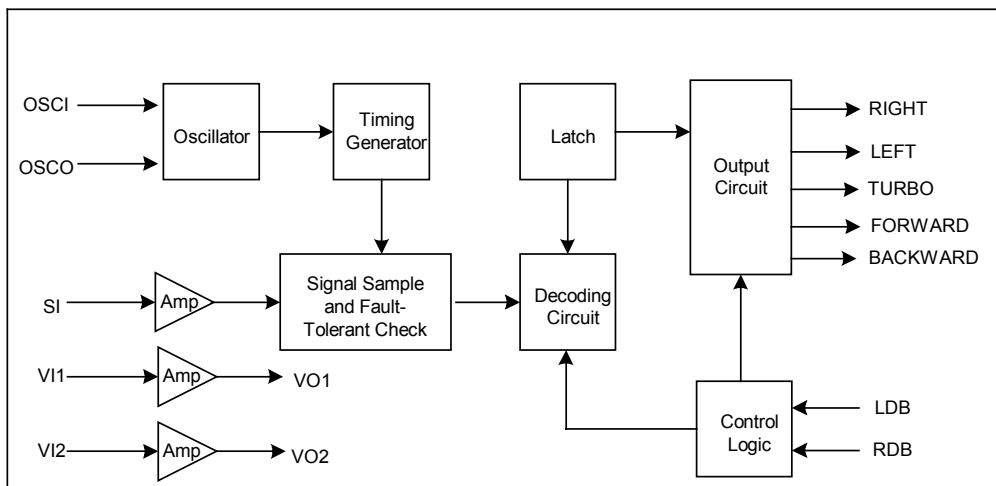

PRODUCT PIN CONFIGURATION AND DESCRIPTION

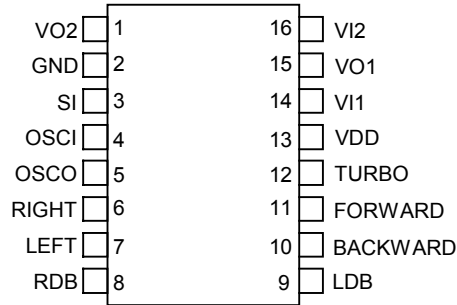

| Pin No. | Pin Name | Description |
|---------|----------|---|
| 1 | VO2 | Output pin for the amplifier 2 |
| 2 | GND | Negative power supply |
| 3 | SI | Input pin of the encoding signal |
| 4 | OSCI | Oscillator input pin |
| 5 | OSCO | Oscillator output pin |
| 6 | RIGHT | Rightward output pin |
| 7 | LEFT | Leftward output pin |
| 8 | RDB | Rightward function disable, if this pin is connected to GND |
| 9 | LDB | Leftward function disable, if this pin is connected to GND |
| 10 | BACKWARD | Backward output pin |
| 11 | FORWARD | Forward output pin |
| 12 | TURBO | Turbo output pin |
| 13 | VDD | Positive power supply |
| 14 | VI1 | Input pin for the amplifier 1 |
| 15 | VO1 | Output pin for the amplifier 1 |
| 16 | VI2 | Input pin for the amplifier 2 |

ABSOLUTE MAXIMUM RATINGS

| PARAMETER | SYMBOL | VALUE | UNIT |
|---|-----------|-------------|------|
| DC Input Voltage | V_{IN} | -0.5 ~ +5.5 | V |
| Supply Voltage to Ground Potential(Inputs &VDD Only) | | -0.5 ~ +5.5 | V |
| Supply Voltage to Ground Potential(Outputs &D/O Only) | | -0.5 ~ +5.5 | V |
| DC Output Current | I_o | 20 | mA |
| Power Dissipation | P_D | 500 | mW |
| Ambient Temperature With Power Applied | T_A | -10 ~ +40 | °C |
| Storage Temperature | T_{STG} | -25 ~ +85 | °C |

DC ELECTRICAL CHARACTERISTICS(Over the operating rating, TA= -10°C~ +40°C, VDD=4.0V±10%)

| PARAMETER | SYMBOL | TEST CONDITIONS | MIN | TYP | MAX | UNITS |
|---------------------|--------|----------------------|------|-----|-----|-------|
| Operating Voltage | VDD | | 2.5 | 4.0 | 5.0 | V |
| Supply Current | IDD | * | | | 3.0 | mA |
| Input Current | IIN | For RDB and LDB pins | | | 60 | μA |
| Input Low Voltage | VIL | For RDB and LDB pins | | | 0.5 | V |
| Input High Voltage | VIH | For RDB and LDB pins | 3.5 | | | V |
| Output High Voltage | VOH | IOU=400μA | 3.5 | | | V |
| Output High Current | IOH | VOU=1.4V | -1.5 | | | mA |
| Output Low Voltage | VOL | IOU=1.0mA | | | 0.5 | V |
| Output Low Current | IOL | VOU=0.5V | 1.0 | | | mA |

Note*:Output unloads; 2.2MΩ feedback resistors for the two reversing amplifiers; 200KΩ external resistor for the on-chip oscillator.

AC ELECTRICAL CHARACTERISTICS(Over the operating rating, TA= -10°C~ +40°C, VDD=4.0V±10%)

| PARAMETER | SYMBOL | TEST CONDITIONS | MIN | TYP | MAX | UNITS |
|--------------------------------|--------|-------------------------------|------|-----|------|-------|
| Oscillator Frequency* | Fosc | TA=25°C,R=200KΩ | 102 | 128 | 154 | KHz |
| SI Pin Vpp Receive Sensitivity | VSI | Guaranteed Effective Decoding | 300 | | | mV |
| Cycle Time of Function Code | TFUN | Fosc=128KHz | 0.75 | 1 | 1.25 | ms |
| Cycle Time of Start Code | TSTA | Fosc=128KHz | 1.5 | 2 | 2.5 | ms |

Note*:The relative error between the frequencies of the two on-chip oscillators in the RCT02 and RCR02 must be less than ±25%

BIT FORMAT FOR THE RECEIVED SIGNAL (W1 is used for function codes,W2 for start codes)

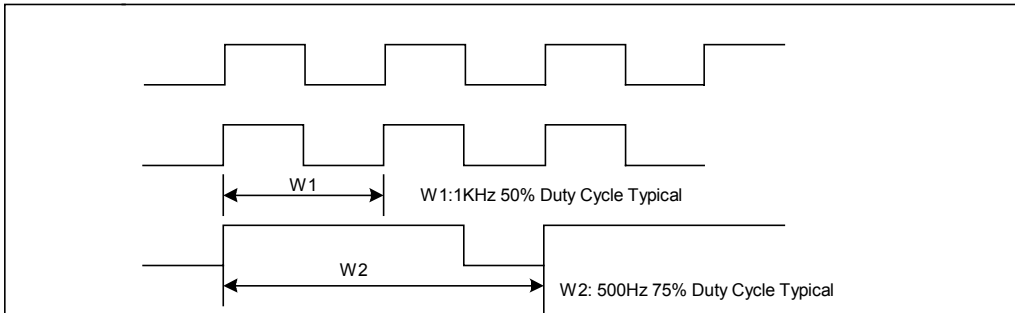

WORD FORMAT FOR RECEIVED SIGNAL

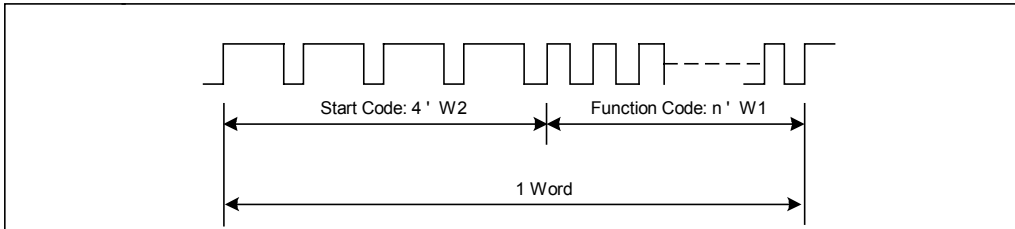

ENCODING INPUT FORMAT AND DECODING RESULT

W2 W2 W2 W2 (n)' W1 W2 W2 W2 W2 (n)' W1 W2 W2 W2 W2 (n)' W1 W2 W2 W2 W2 (n)' W1-----

| Number of Function Codes(n)W1 | Decoding Result |
|-------------------------------|------------------|
| 4 | End Code |
| 10 | Forward |
| 16 | Forward |
| 22 | Turbo |
| 28 | Forward & Left |
| 34 | Forward & Right |
| 40 | Backward |
| 46 | Backward & Right |
| 52 | Backward & Left |
| 58 | Left |
| 64 | Right |

DECODING TIMING

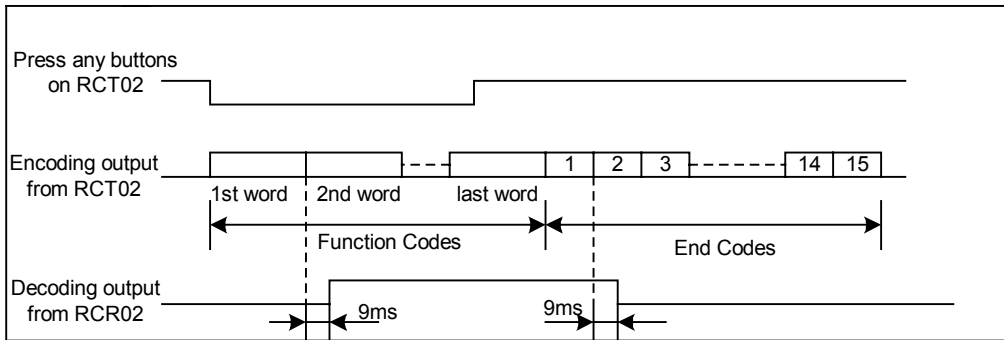

BLOCK DIAGRAM OF APPLICATION CIRCUIT

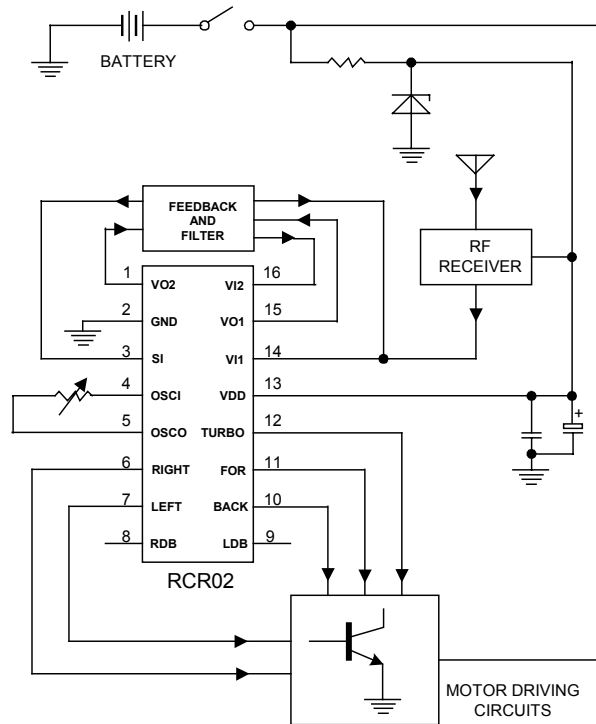

TYPICAL APPLICATION FOR RECEIVE CIRCUIT WITH FIVE FUNCTION

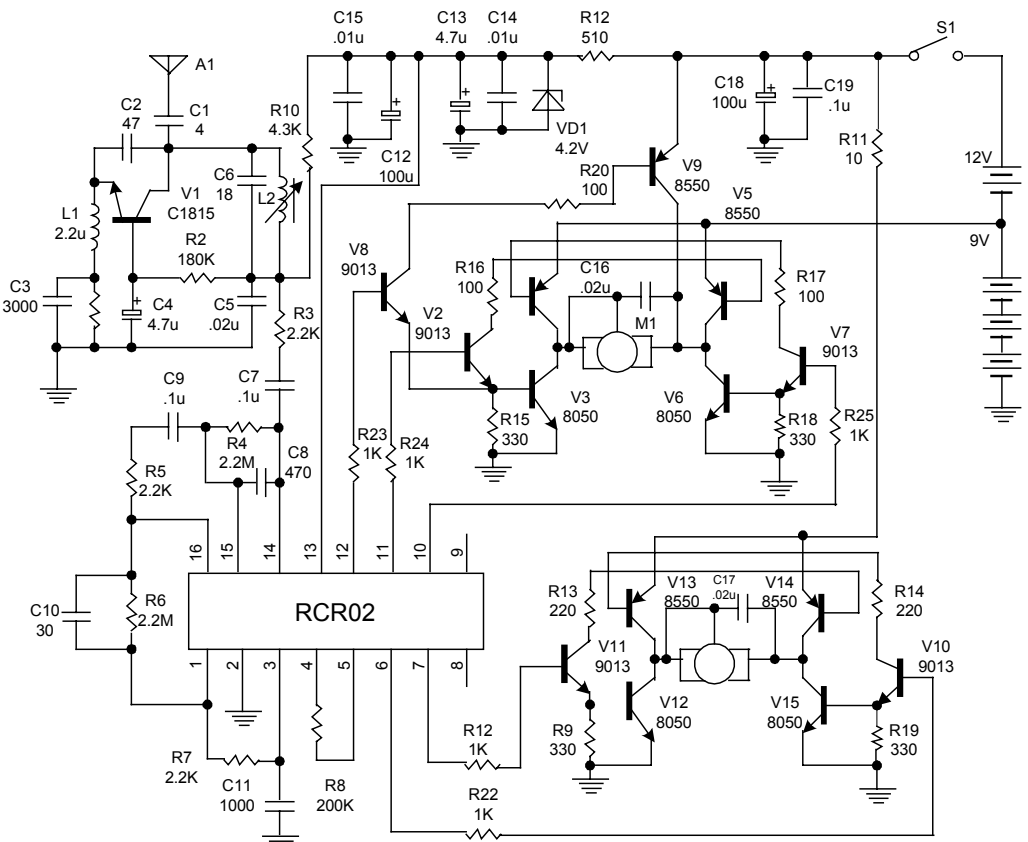

UTC assumes no responsibility for equipment failures that result from using products at values that exceed, even momentarily, rated values (such as maximum ratings, operating condition ranges, or other parameters) listed in products specifications of any and all UTC products described or contained herein. UTC products are not designed for use in life support appliances, devices or systems where malfunction of these products can be reasonably expected to result in personal injury. Reproduction in whole or in part is prohibited without the prior written consent of the copyright owner. The information presented in this document does not form part of any quotation or contract, is believed to be accurate and reliable and may be changed without notice.