



75185

LINEAR INTEGRATED CIRCUIT

MULTIPLE RS-232 DRIVERS AND RECEIVERS

DESCRIPTION

The UTC **75185** complies with the requirements of the TIA/EIA232-F and ITU (formerly CCITT) v.28 standards. These standards are for data interchange between a host computer and peripheral at signaling rates up to 20kbit/s. The switching speeds of the UTC **75185** are fast enough to support rates up to 120kbit/s with lower capacitive loads (shorter cables). Interoperability at the higher signaling rates cannot be assured unless the designer has design control of the cable and the interface circuits at both ends. For interoperability at signaling rates to 120kbit/s, use of ITA/EIA-423-B (ITU v.10) and TIA/EIA-422-B (ITU v.11) standards are recommended.

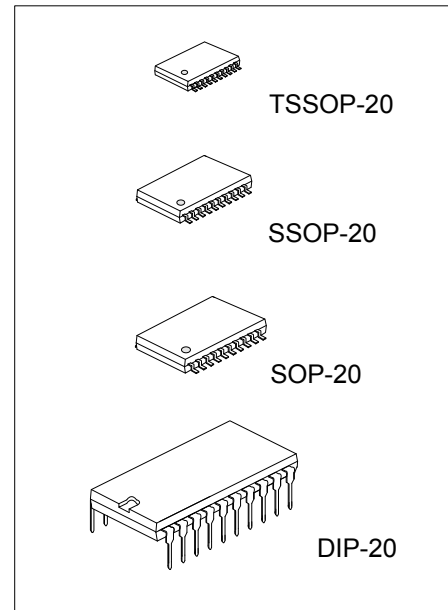

FEATURES

- *Single Chip with Easy Interface between UART and Serial-Port connector of PC.
- *Three Drivers and five Receivers Meet or Exceed the Requirements of TIA/EIA-232-F and ITU v.28 Standards.
- *Designed to Support Data Rates up to 120 kbps

ORDERING INFORMATION

	Ordering Number			Package	Packing
	Normal	Lead Free Plating	Halogen Free		
75185-D20-T	75185L-D20-T	75185G-D20-T	DIP-20	Tube	
75185-P20-R	75185L-P20-R	75185G-P20-R	TSSOP-20	Tape Reel	
75185-R20-R	75185L-R20-R	75185G-R20-R	SSOP-20	Tape Reel	
75185-S20-R	75185L-S20-R	75185G-S20-R	SOP-20	Tape Reel	

<p>75185L-D20-T</p>	<p>(1) Packing Type (2) Package Type (3) Lead Plating</p>	<p>(1) R: Tape Reel, T: Tube (2) D20: DIP-20, S20: SOP-20, P20: TSSOP-20, R20: SSOP-20 (3) G: Halogen Free, L: Lead Free, Blank: Pb/Sn</p>
---------------------	-------------------------------------------------------------------	----------------------------------------------------------------------------------------------------------------------------------------------------

■ PIN CONFIGURATIONS

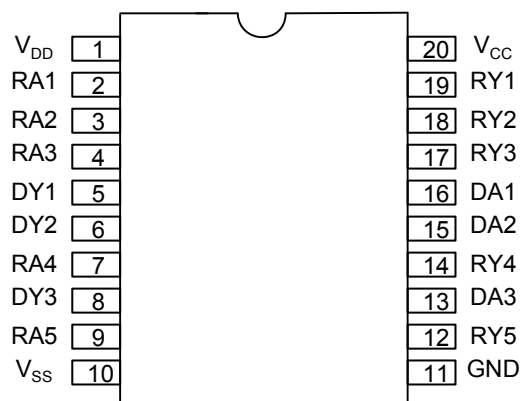

■ PIN DESCRIPTION

PIN NO	SYMBOL	PIN DESCRIPTION
1	V _{DD}	Supply Voltage
2	RA1	First Receiver Input
3	RA2	Second Receiver Input
4	RA3	Third Receiver Input
5	DY1	First Driver Output
6	DY2	Second Driver Output
7	RA4	Fourth Receiver Input
8	DY3	Third Driver Output
9	RA5	Fifth Receiver Input
10	V _{SS}	Supply Voltage
11	GND	Ground
12	RY5	Fifth Receiver Output
13	DA3	Third Driver Input
14	RY4	Fourth Receiver Output
15	DA2	Second Driver Input
16	DA1	First Driver Input
17	RY3	Third Receiver Output
18	RY2	Second Receiver Output
19	RY1	First Receiver Output
20	V _{CC}	Supply Voltage

■ **ABSOLUTE MAXIMUM RATINGS OVER OPERATING FREE-AIR TEMPERATURE RANGE** (unless otherwise specified)

PARAMETER		SYMBOL	RATINGS	UNIT
Supply Voltage (Note 1)		V_{DD}	15	V
		V_{SS}	-15	V
		V_{CC}	10	V
Input Voltage Range	Drive	V_{IN}	-15 ~ 7	V
	Receiver		-30 ~ 30	V
Driver Output Voltage Range		V_{OUT}	-15~ 15	V
Receiver Low Level Output Current		I_{OUT}	20	mA
Storage Temperature Range		T_{STG}	-65 ~ +150	°C

■ **THERMAL DATA**

PARAMETER		SYMBOL	RATINGS	UNIT
Junction to Ambient	DIP-20	θ_{JA}	70	°C/W
	SOP-20		100	
	SSOP-20		115	
	TSSOP-20		115	

Note 1: All voltage are with respect to the network ground terminal.

Note 2: The package thermal impedance is calculated in accordance with JESD 51, except for through-hole packages, which use a trace length of zero.

■ **RECOMMENDED OPERATING CONDITIONS**

PARAMETER		SYMBOL	MIN	TYP	MAX	UNIT
Supply Voltage		V_{DD}	7.5	9	15	V
		V_{SS}	-7.5	-9	-15	V
		V_{CC}	4.5	5	5.5	V
Input Voltage (Driver Only)	High Level	V_{IH}	1.9			V
	Low Level	V_{IL}			0.8	V
High Level Output Current	Drive	I_{OH}			-6.0	mA
	Receiver				-0.5	
Low Level Output Current	Drive	I_{OL}			6	mA
	Receiver				16	
Operating Free-Air Temperature		T_A	0		70	°C

■ **SUPPLY CURRENTS**

PARAMETER	SYMBOL	TEST CONDITIONS			MIN	MAX	UNIT
			V_{DD}	V_{SS}			
Supply Current From V_{DD}	I_{DD}	No load. All inputs at 1.9V	9	-9		15	mA
			12	-12		19	
			15	-15		25	
		No load. All inputs at 0.8V	9	-9		4.5	mA
			12	-12		5.5	
			15	-15		9	
Supply Current From V_{SS}	I_{SS}	No load. All inputs at 1.9V	9	-9		-15	mA
			12	-12		-19	
			15	-15		-25	
		No load. All inputs at 0.8V	9	-9		-3.2	mA
			12	-12		-3.2	
			15	-15		-3.2	
Supply Current From V_{CC}	I_{CC}	No load. All inputs at 5V, $V_{CC}=5V$				30	mA

■ **DRIVER ELECTRICAL CHARACTERISTICS OVER RECOMMENDED OPERATING FREE-AIR TEMPERATURE RANGE** ($V_{DD}=9V$, $V_{SS}=-9V$, $V_{CC}=5V$, unless otherwise specified)

PARAMETER	SYMBOL	TEST CONDITIONS	MIN	TYP	MAX	UNIT
High Level Output Voltage	V_{OH}	$V_{IL}=0.8V$, $R_L=3\text{ k}\Omega$ (Figure 1)	6	7.5		V
Low Level Output Voltage (Note 3)	V_{OL}	$V_{IH}=1.9V$, $R_L=3\text{ k}\Omega$ (Figure 1)		-7.5	-6	V
High Level Input Current	I_{IH}	$V_{IN}=5V$ (Figure 2)			10	μA
Low Level Input Current	I_{IL}	$V_{IN}=0V$ (Figure 2)			-1.6	mA
High Level Short Circuit Output Current (Note 4)	$I_{OS(H)}$	$V_{IL}=0.8V$, $V_{OUT}=0V$ (Figure 1)	-4.5	-12	-19.5	mA
Low Level Short Circuit Output Current	$I_{OS(L)}$	$V_{IH}=2V$, $V_{OUT}=0V$ (Figure 1)	4.5	12	19.5	mA
Output Resistance (Note 5)	R_{OUT}	$V_{DD}=V_{SS}=V_{CC}=0V$, $V_{OUT}=-2\text{ to }2V$	300			Ω

Note 3: The algebraic convention, where the more positive (less negative) limit is designated as maximum, is used in this datasheet for logic levels only (e.g. if -10V is a maximum, the typical value is a more negative voltage).

Note 4: Output short circuit conditions must maintain the total power dissipation below absolute maximum ratings.

Note 5: Test conditions are those specified by TIA/EIA232-F and as listed above.

■ **DRIVER SWITCHING CHARACTERISTICS** ($V_{DD}=12V$, $V_{SS}=-12V$, $V_{CC}=5V$, $T_A=25^\circ\text{C}$)

PARAMETER	SYMBOL	TEST CONDITIONS	MIN	TYP	MAX	UNIT	
Propagation Delay Time Level Output	Low to High	t_{PLH}	$R_L=3\text{ to }7\text{ k}\Omega$, $C_L=15\text{pF}$ (Figure 3)		315	500	ns
	High to Low	t_{PHL}	$R_L=3\text{ to }7\text{ k}\Omega$, $C_L=15\text{pF}$ (Figure 3)		75	175	ns
Transition Time Level Output	Low to High	t_{TLH}	$R_L=3\text{ to }7\text{ k}\Omega$, $C_L=15\text{pF}$ (Figure 3)		60	100	ns
			$R_L=3\text{ to }7\text{ k}\Omega$, $C_L=2500\text{pF}$ (Note 6, Figure 3)		1.7	2.5	μs
Transition Time Level Output	High to Low	t_{THL}	$R_L=3\text{ to }7\text{ k}\Omega$, $C_L=15\text{pF}$ (Figure 3)		40	75	ns
			$R_L=3\text{ to }7\text{ k}\Omega$, $C_L=2500\text{pF}$ (Note 7, Figure 3)		1.5	2.5	μs

Note 6: Measured between -3V and 3V points of the output waveform (TIA/EIA-232-F conditions), all unused inputs are tied.

Note 7: Measured between 3V and -3V points of the output waveform (TIA/EIA-232-F conditions), all unused inputs are tied.

■ **RECEIVER ELECTRICAL CHARACTERISTICS OVER RECOMMENDED OPERATING CONDITIONS** ($T_A=25^\circ\text{C}$, $V_{CC}=5V$, $V_{DD}=9V$, $V_{SS}=-9V$)

PARAMETER	SYMBOL	TEST CONDITIONS	MIN	TYP	MAX	UNIT	
Positive Going Threshold Voltage	V_{T+}	(Figure 5) $T_A=25^\circ\text{C}$ $T_A=0^\circ\text{C to }70^\circ\text{C}$	1.75 1.55	1.9	2.3 2.3	V	
Negative Going Threshold Voltage	V_{T-}		0.75	0.97	1.25	V	
Input Hysteresis ($V_{T+} - V_{T-}$)	V_{HYS}		0.5			V	
Output Voltage	High level	V_{OH}	$I_{OH}=-0.5\text{mA}$	$V_{IH}=0.75V$ Inputs Open	2.6 2.6	4 5	V
	Low level	V_{OL}	$V_{IN}=3V$, $I_{OL}=10\text{mA}$		0.2	0.45	V
Input Current	High level	I_{IH}	$V_{IN}=25V$ (Figure 5)		3.6	8.3	mA
			$V_{IN}=3V$ (Figure 5)		0.43		
	Low level	I_{IL}	$V_{IN}=-25V$ (Figure 5) $V_{IN}=-3V$ (Figure 5)		-3.6 -0.43	-8.3	mA
Short-Circuit Output Current	I_{OS}	(Figure 4)		-3.4	-12	mA	

■ **RECEIVER SWITCHING CHARACTERISTICS** ($V_{DD}=12V$, $V_{SS}=-12V$, $V_{CC}=5V$, $T_A=25^\circ\text{C}$)

PARAMETER	SYMBOL	TEST CONDITIONS	MIN	TYP	MAX	UNIT	
Propagation Delay Time Level Output	Low to High	t_{PLH}	$R_L=5\text{ k}\Omega$, $C_L=50\text{pF}$ (Figure 6)		107	500	ns
	High to Low	t_{PHL}			42	150	ns
Transition Time Level Output	Low to High	t_{TLH}			175	525	ns
	High to Low	t_{THL}			16	60	ns

PARAMETER MEASUREMENT INFORMATION

DRIVER TEST CIRCUITS:

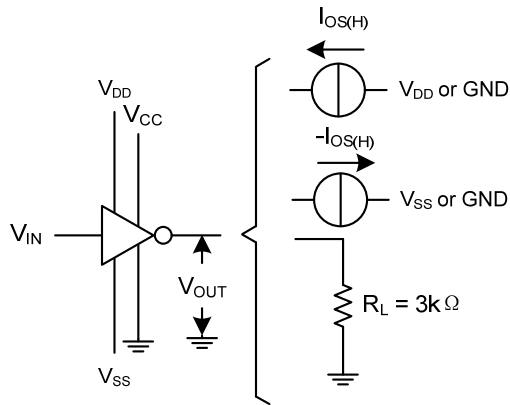

Figure 1. For V_{OH} , V_{OL} , $I_{OS(H)}$, $I_{OS(L)}$

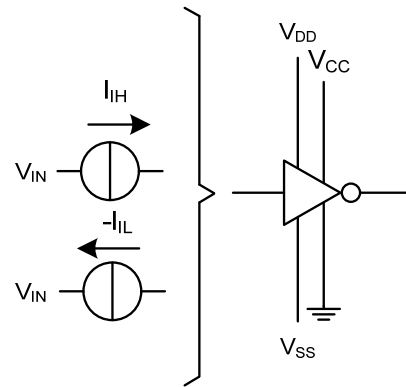

Figure 2. For I_{IH} , I_{IL}

DRIVER VOLTAGE WAVEFORMS:

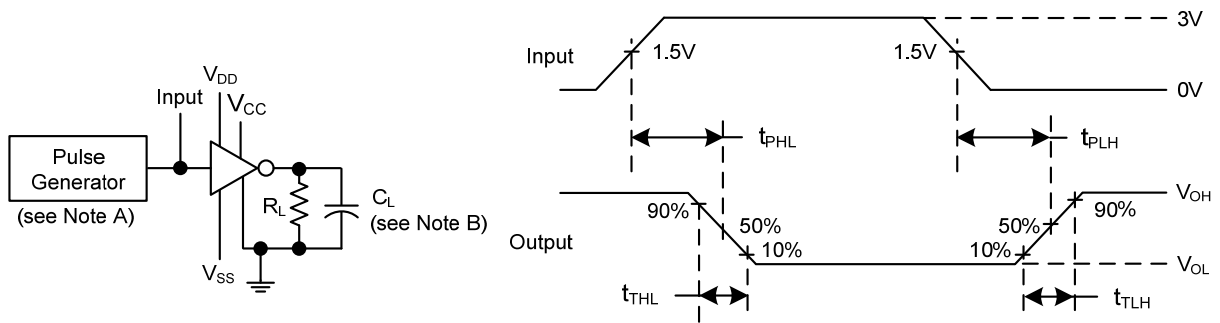

Figure 3.

- Note 1. The pulse generator has the following characteristics: $t_w=25\mu s$, $PRR=20kHz$, $Z_o=50\Omega$, $t_r=t_f<50ns$.
- 2. C_L includes probe and jig capacitance.

PARAMETER MEASUREMENT INFORMATION (Cont.)

RECEIVER TEST CIRCUITS:

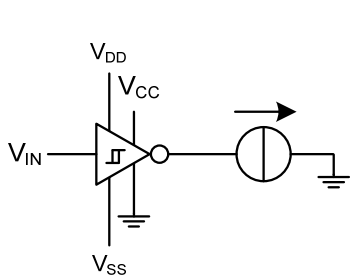

Figure 4. For I_{0S}

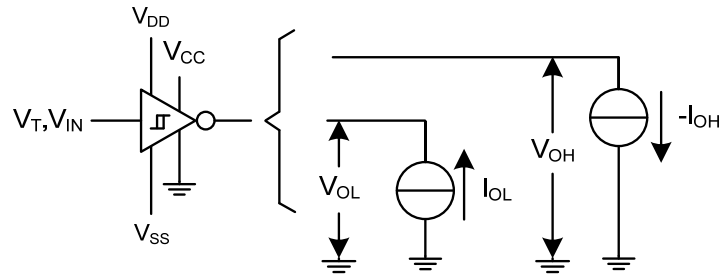

Figure 5. For V_T , V_{OH} , V_{OL}

RECEIVER PROPAGATION AND TRANSITION TIMES:

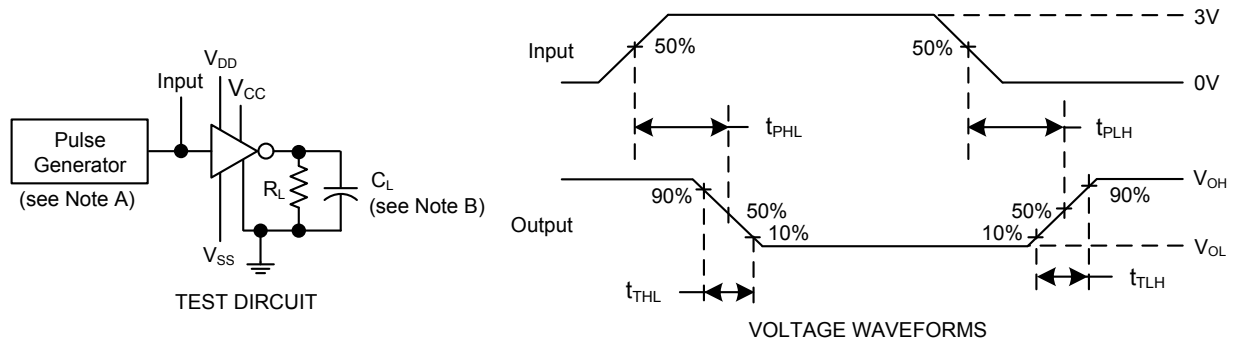

Figure 6.

- Note 1. The pulse generator has the following characteristics: $t_w=25\mu s$, $PRR=20kHz$, $Z_o=50\Omega$, $t_r=t_f<50ns$.
- 2. C_L includes probe and jig capacitance.

APPLICATION INFORMATION

Power-Supply protection to meet Power-Off fault conditions of TIA/TIA-232-F

Diodes placed in series with the V_{DD} and V_{SS} leads protect the device in the fault condition in which the device outputs are shorted to $\pm 15V$ and the power supplies are at low and provide low-impedance paths to ground.

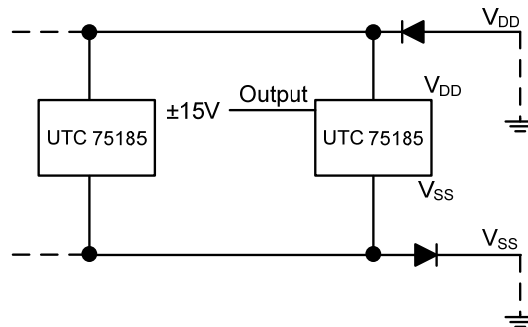

Typical Connection

“*”: Refer Figure 10 to select the correct values for the loading capacitors (C1, C2, and C3), which are required to meet the RS-232 maximum slew-rate requirement of $30V/\mu s$. The value of the loading capacitors required depends upon the line length and desired slew rate, but typically is 330 pF.

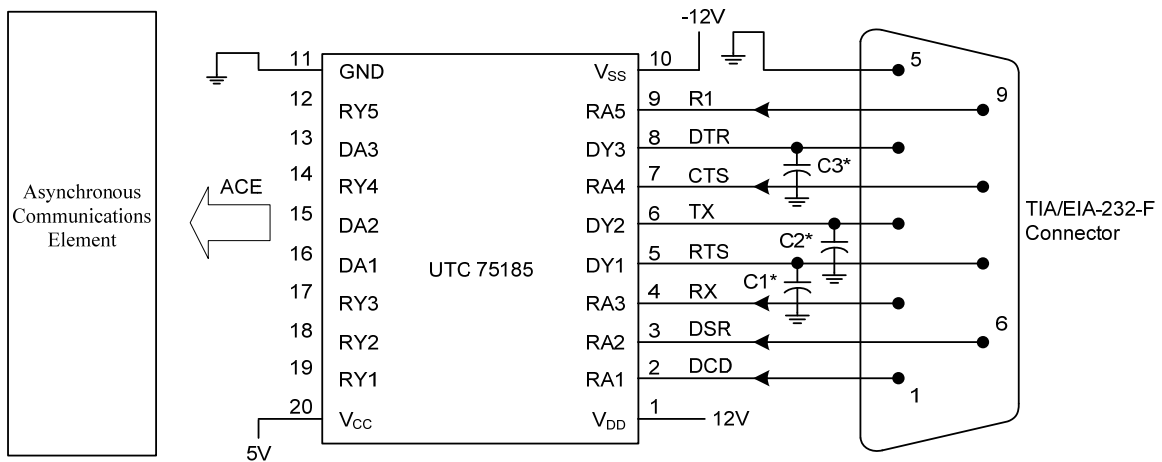

LOGIC SYMBOL AND LOGIC DIAGRAM

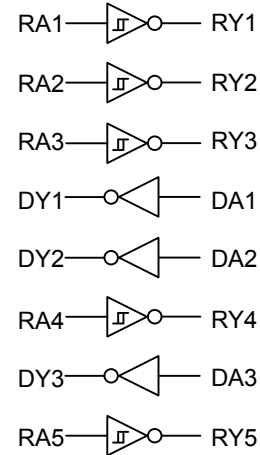
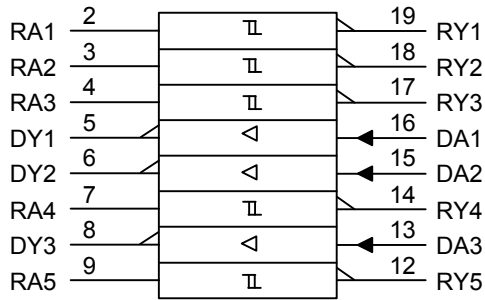

CIRCUIT OF DRIVERS (Resistor value shown are nominal.)

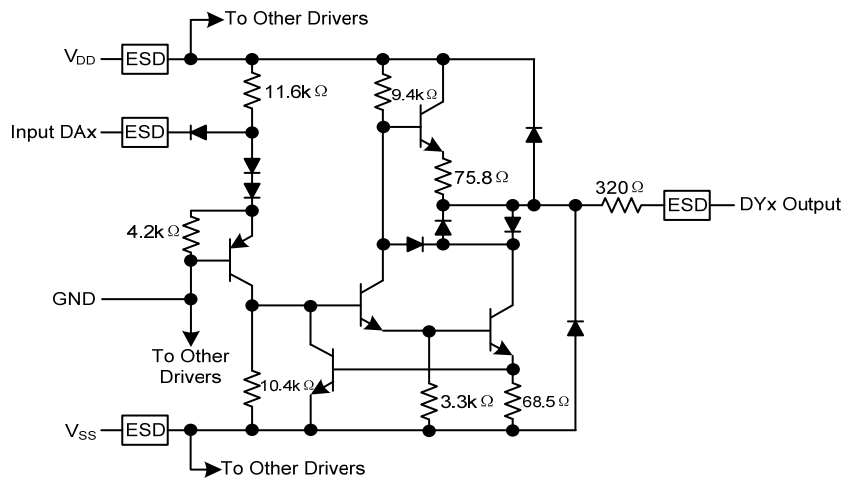

CIRCUIT OF EACH RECEIVER (Resistor value shown are nominal.)

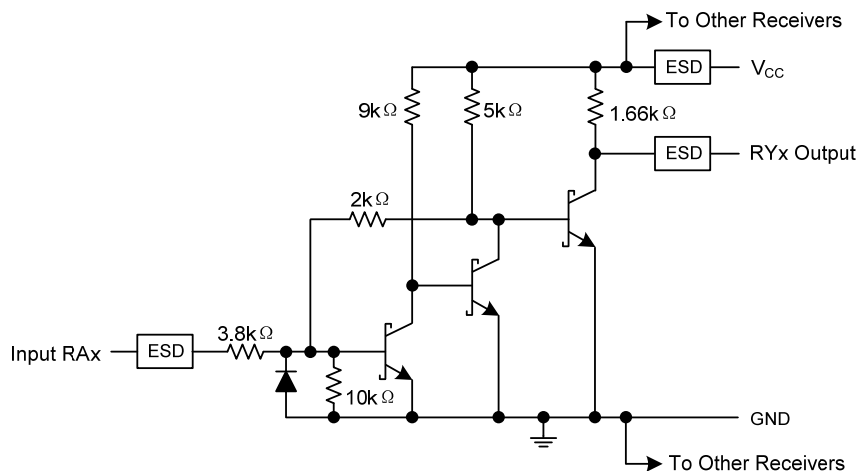

■ TYPICAL CHARACTERISTICS (DRIVER)

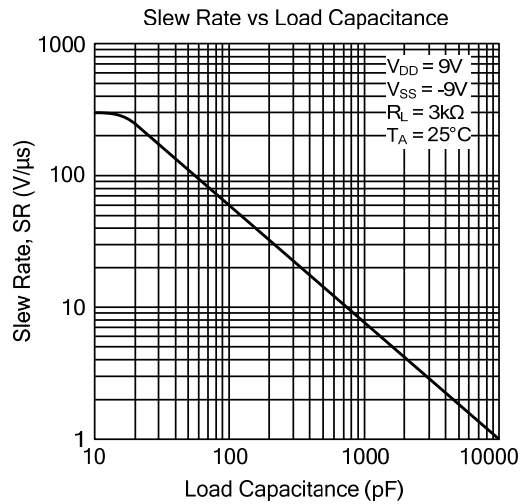
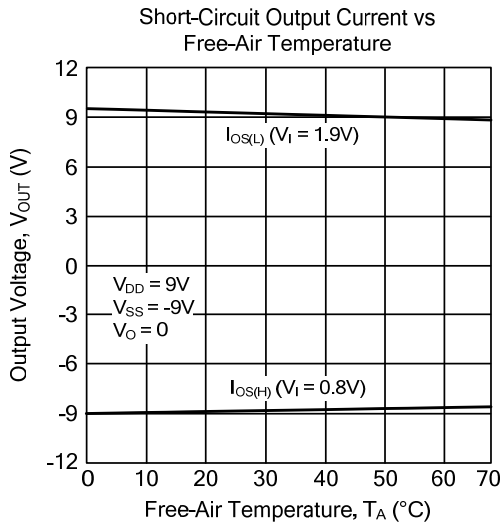
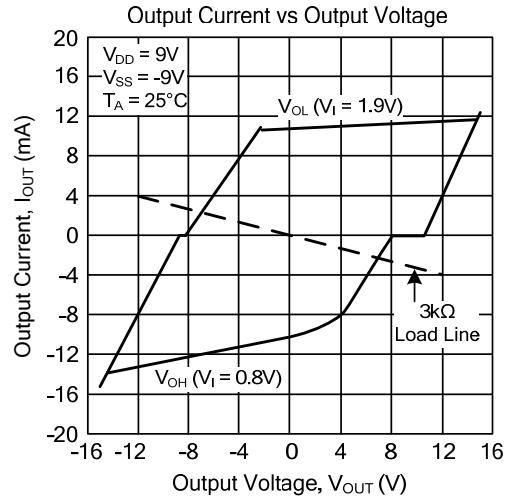
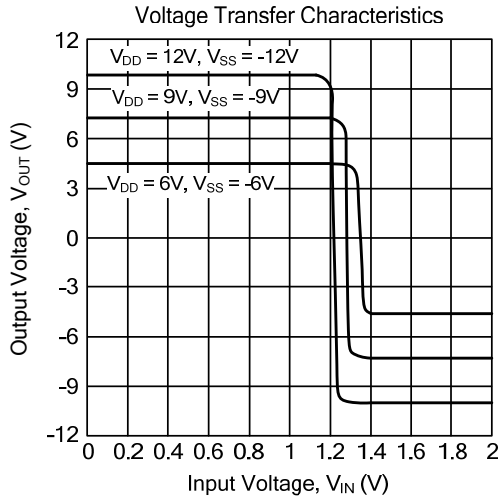

■ TYPICAL CHARACTERISTICS (RECEIVER)

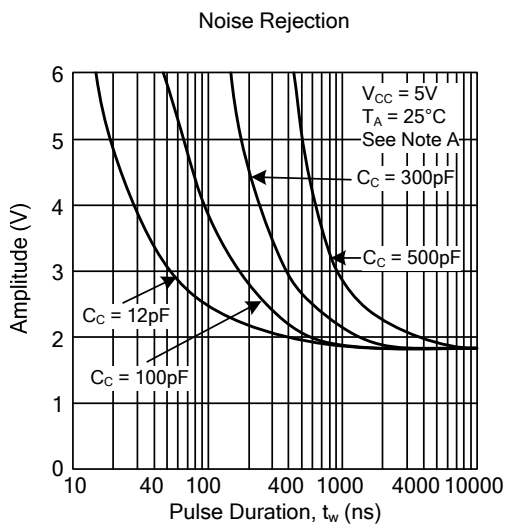
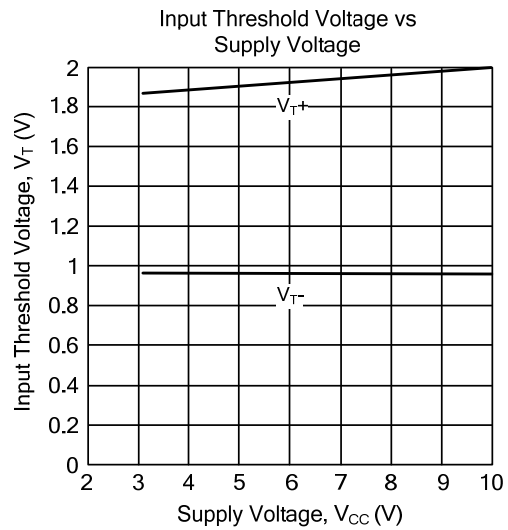
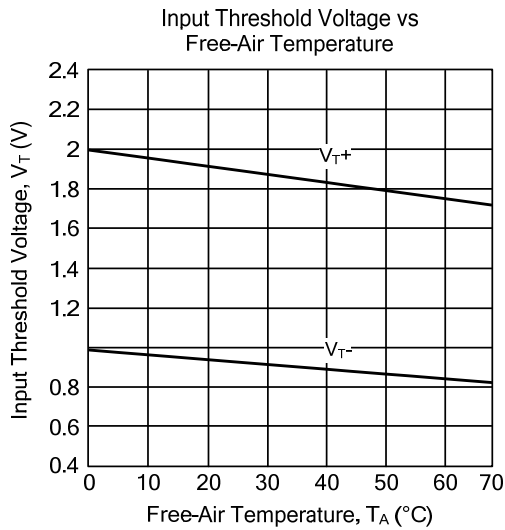

The maximum amplitude starting from 0V of a positive-going pulse that will not cause a change in the output level.

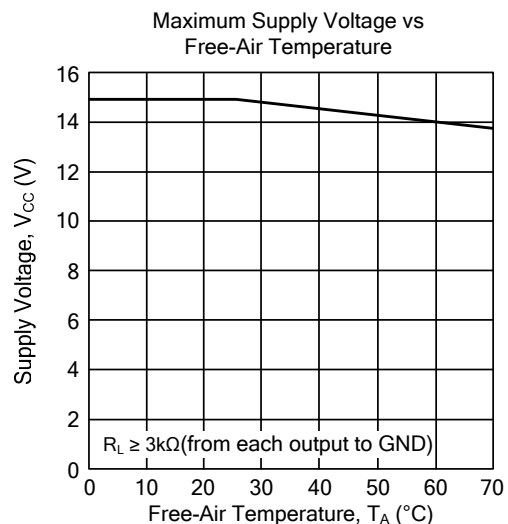

UTC assumes no responsibility for equipment failures that result from using products at values that exceed, even momentarily, rated values (such as maximum ratings, operating condition ranges, or other parameters) listed in products specifications of any and all UTC products described or contained herein. UTC products are not designed for use in life support appliances, devices or systems where malfunction of these products can be reasonably expected to result in personal injury. Reproduction in whole or in part is prohibited without the prior written consent of the copyright owner. The information presented in this document does not form part of any quotation or contract, is believed to be accurate and reliable and may be changed without notice.