



319

Preliminary

LINEAR INTEGRATED CIRCUIT

SINGLE PHASE DC MOTOR DRIVE IC

DESCRIPTION

The UTC 319 is particularly designed for a single phase DC motor driver circuit. It includes hall sensor and output coil drivers. The range of the operating voltage and the operation current is typically 0.3A.

The UTC 319 is a well performance integrated IC with less required external components. The high sensitivity of Hall effect sensor is suitable for motors from mini-type CPU coolers to blowers and DC fans.

FEATURES

- * Operating Voltage Ranges Widely from 3.0V to 20V
- * 1 Chip Hall Sensor/Drivers
- * Output Thermal Shutdown Protect Circuit
- * Output Sink Current up to 300mA

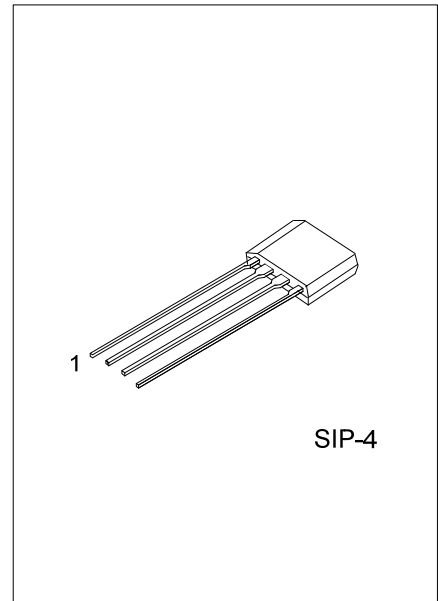

ORDERING INFORMATION

Ordering Number		Package	Packing
Lead Free	Halogen Free		
319L-G04-K	319G-G04-K	SIP-4	Bulk

<p>319G-G04-T</p> <p>(1) Packing Type (2) Package Type (3) Halogen Free</p>	<p>(1) K: Bulk (2) G04: SIP-4 (3) G: Halogen Free, L: Lead Free</p>
---	---

PIN DESCRIPTION

PIN NO.	PIN NAME	DESCRIPTION
1	V _{CC}	IC Power Supply
2	NO	Coil driver output is low state during the N magnetic field.
3	SO	Coil driver output is low state during the S magnetic field.
4	GND	IC Ground

■ BLOCK DIAGRAM

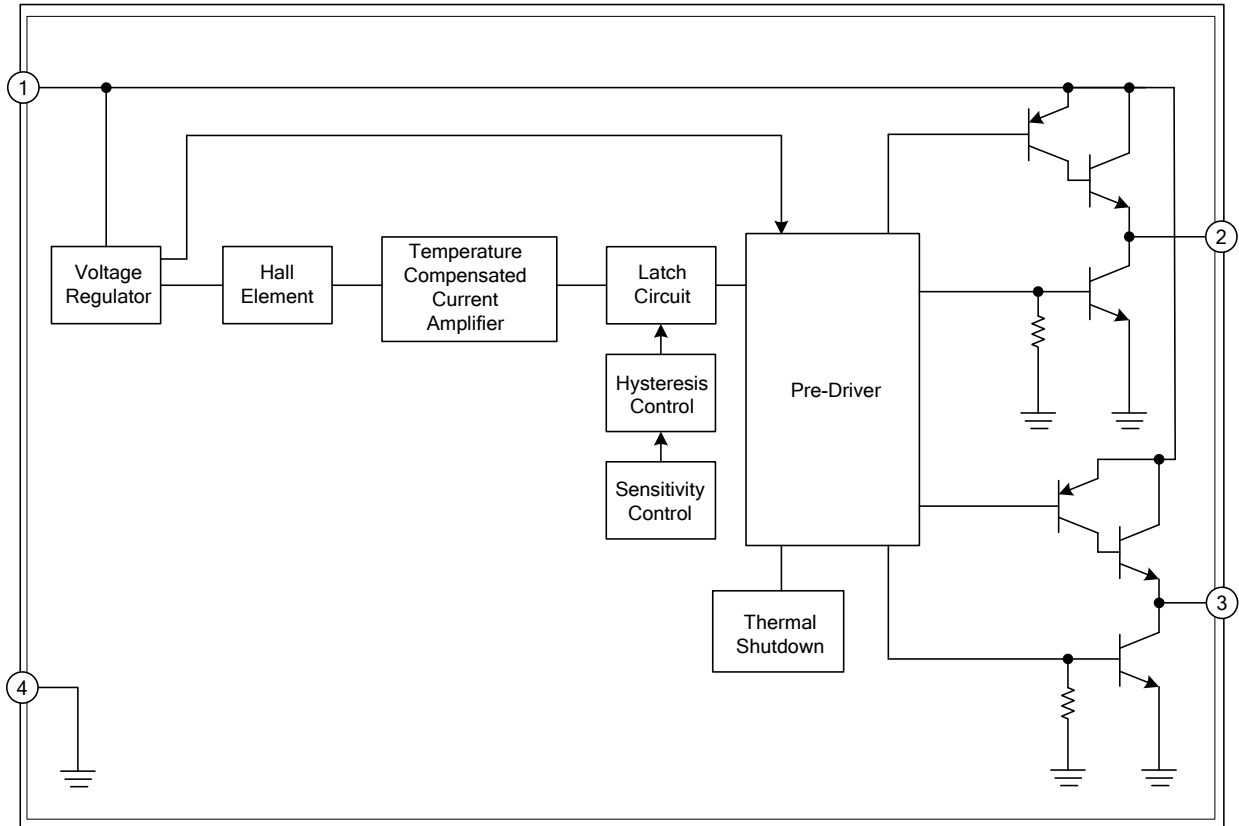

■ ABSOLUTE MAXIMUM RATING

PARAMETER		SYMBOL	RATINGS	UNIT
V _{CC} Pin Voltage			20	V
Output Peak Sink Current	Peak Current	I _{OUT}	800	mA
	Hold Current		600	mA
	Continuous Current		300	mA
Power Dissipation	T _A =25°C	P _D	600	mW
	T _A =70°C		450	mW
Junction Temperature		T _J	+150	°C
Operating Junction Temperature		T _J	0 ~ +85	°C
Storage Temperature		T _{STG}	-65 ~ +150	°C

Note: Absolute maximum ratings are those values beyond which the device could be permanently damaged. Absolute maximum ratings are stress ratings only and functional device operation is not implied.

■ DC ELECTRICAL CHARACTERISTICS

PARAMETER	SYMBOL	TEST CONDITIONS	MIN	TYP	MAX	UNIT
Supply Voltage	V _{CC}		3		20	V
Quiescent Supply Current	I _{VV}	V _{CC} =20V, No use pin open		18	25	mA
Output Saturation Voltage	V _{CE(SINK)}	V _{CC} =14V, I _C =200mA		0.55	0.8	V
	V _{CE(DRIVE)}	V _{CC} =14V, I _C =200mA	12.5		14	V

■ AC ELECTRICAL CHARACTERISTICS

PARAMETER	SYMBOL	TEST CONDITIONS	MIN	TYP	MAX	UNIT
Rise Time	t _R	R _L =820Ω, C _L =20pF		0.5	1.0	μs
Fall Time	t _F	R _L =820Ω, C _L =20pF		0.5	1.5	μs
Switch Time Differential	Δt	R _L =820Ω, C _L =20pF		1.0	0.5	μs

■ MAGNETIC CHARACTERISTICS

A Grade

PARAMETER	SYMBOL	MIN	TYP	MAX	UNIT
Operating Point	B _{OP}	10		45	Gauss
Release Point	B _{RP}	-45		-10	

B Grade

PARAMETER	SYMBOL	MIN	TYP	MAX	UNIT
Operating Point	B _{OP}			65	Gauss
Release Point	B _{RP}	-65			

C Grade

PARAMETER	SYMBOL	MIN	TYP	MAX	UNIT
Operating Point	B _{OP}			90	Gauss
Release Point	B _{RP}	-90			

■ TYPICAL APPLICATION CIRCUIT

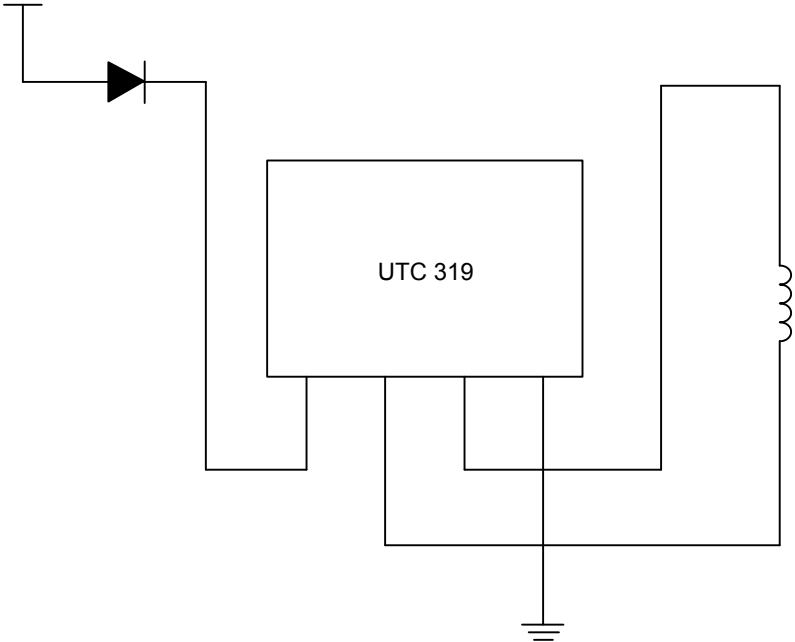

■ APPLICATION CIRCUIT

The Example of Typical Application Circuit

A typical application circuit is shown as follows. The red, yellow, and black wires are the input points of the motor system: Red--the input of power supply; Yellow--the output of FG; Black--the ground signal. R_C is an external pull-up resistance for the use of measuring FG signal.

The value of R_C can be calculated by the transistor saturation voltage (V_{ON}), sink current (I_C), and off-level voltage (V_C).

$$R_C = \frac{V_C - V_{ON}}{I_C}$$

For example:

$V_C = +5V$ for TTL level; $I_C = 10mA$ at 0.2V saturation voltage; The safety value of $R_C = 470 \Omega$

There is a reverse protection diode D1 in the circuit. As if the red and black wires reversely connect with the power source, the current flows through the ground via IC and coils L1 and L2 to power supply. Under such kind of circumstances the IC and coils are easy to be burned out. From that, this reverse protection diode is necessary in the design. Meanwhile, an extra voltage drop on the supply voltage should be taken into consideration, which is caused by the reverse protection diode.

The capacitor C1 is designed to reduce the ripple noise during the transient of the output stages, and its value is determined by the coil impedance and characteristics.

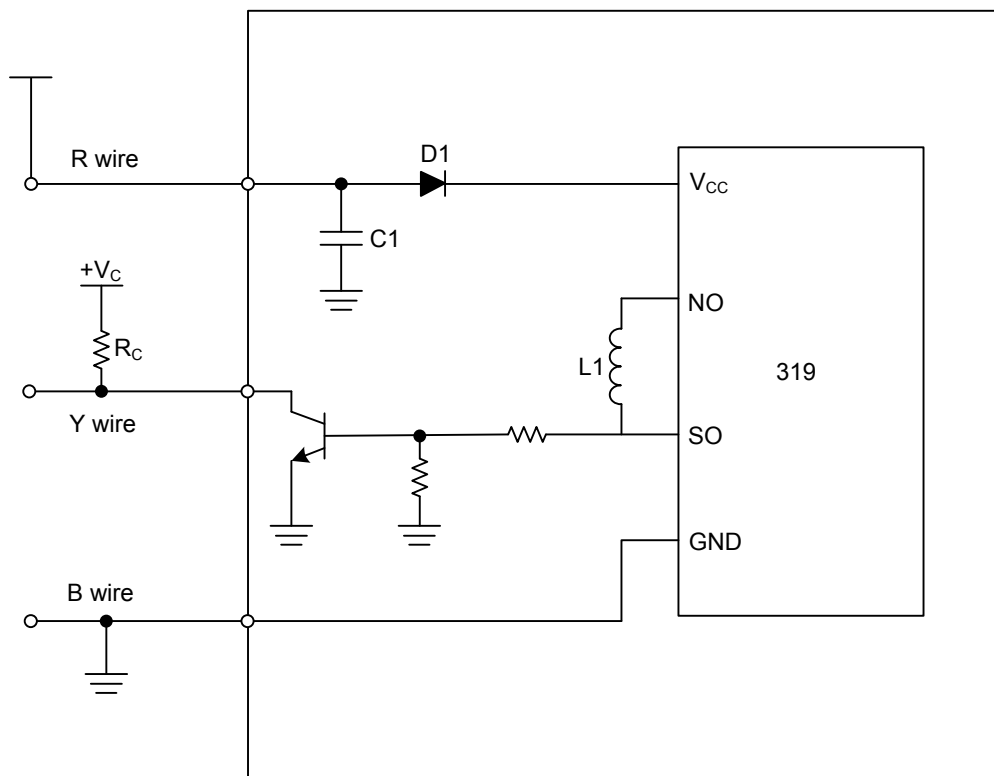

FUNCTIONAL INFORMATION

H-Bridge Transistor Output

In the following figure, the diagram of H-bridge transistors is shown. The single-phase motor rotation is changed by a switching current of coil L1.

When the magnetic pole is N pole, Q2, Q3, Q5 is shut off and Q1, Q4, Q6 is turn-on, the current flows through L1 from SO to NO. And when the magnetic pole is S pole, Q1, Q4, Q6 is turn-off and Q2, Q3 is turned on.

The current flows through L1 from NO to SO.

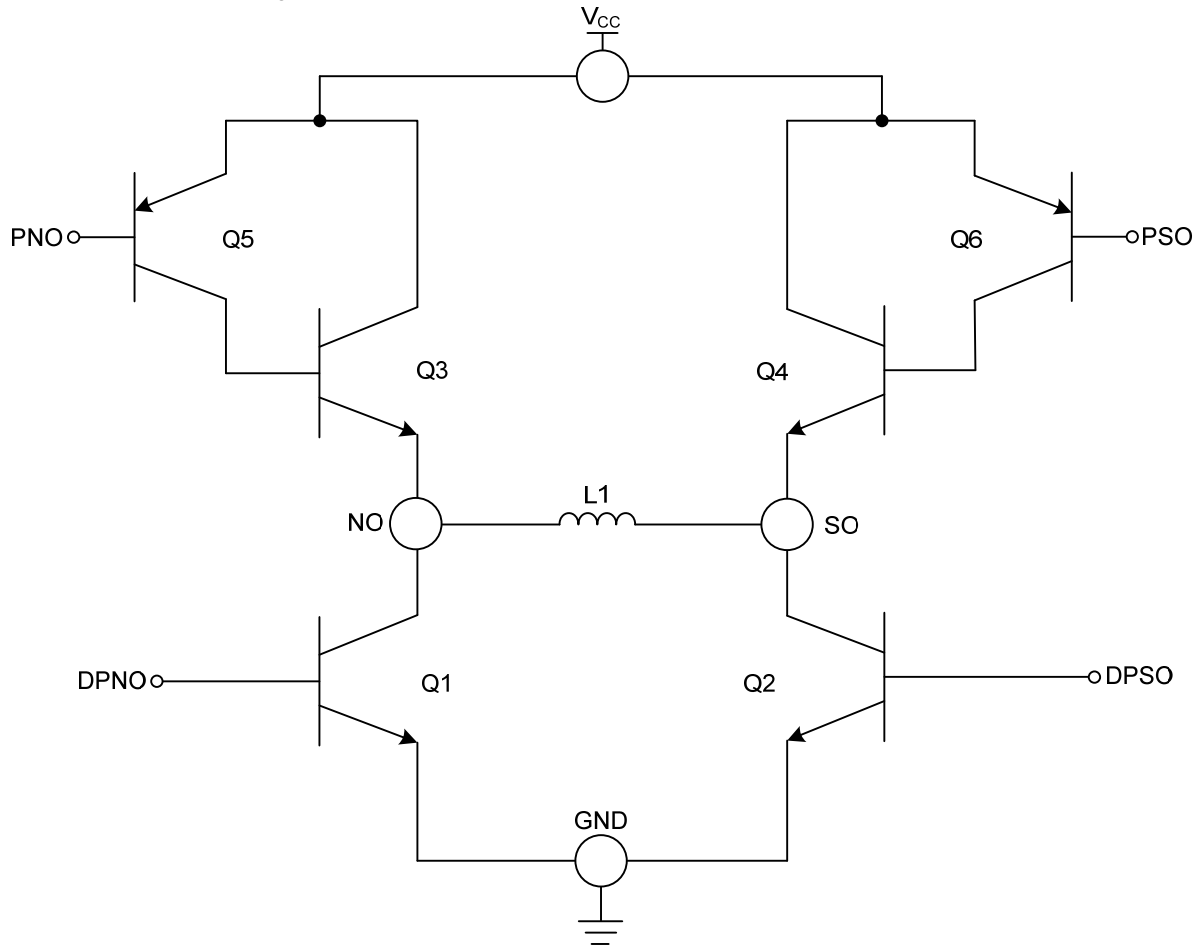

H-Bridge Transistor Output

UTC assumes no responsibility for equipment failures that result from using products at values that exceed, even momentarily, rated values (such as maximum ratings, operating condition ranges, or other parameters) listed in products specifications of any and all UTC products described or contained herein. UTC products are not designed for use in life support appliances, devices or systems where malfunction of these products can be reasonably expected to result in personal injury. Reproduction in whole or in part is prohibited without the prior written consent of the copyright owner. The information presented in this document does not form part of any quotation or contract, is believed to be accurate and reliable and may be changed without notice.