



UH8102

CMOS IC

LOW POWER HALL EFFECT SWITCH

DESCRIPTION

UH8102 is a low-power integrated Hall switch designed to sense the applied magnetic flux density and give a digital output, which indicates the present condition of the magnitude sensed.

It mainly designed for battery-powered system and hand-held equipment, such as cellular flip-phones and PDA's, in which power consumption is one major concern. The typical power consumption of UH8100 at down to 10uW in 2.7V supply.

For **UH8102A**, the output will be at the "Low" level when no magnetic field is applied. When the applied magnetic flux density is stronger than the switching threshold, the output would be at the "High" level.

For **UH8102B**, the output will be at the "High" level when no magnetic field is applied. When the applied magnetic flux density is stronger than the switching threshold, the output would be at the "Low" level.

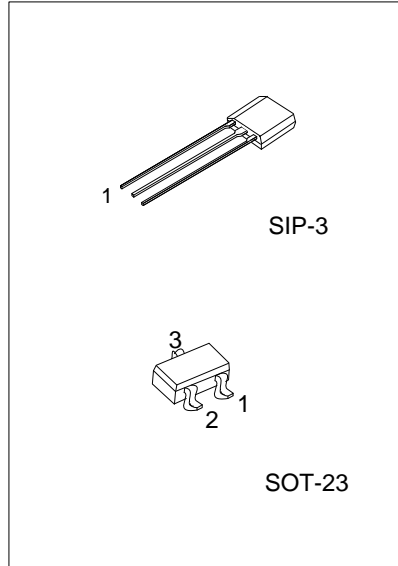

FEATURES

- *Micropower Operation
- *2.4V to 5.5V Battery Operation
- *Offset Canceling Technology
- *Superior Temperature Stability
- *Extremely Low Switch-Point Drift
- *Insensitive to Physical Stress

ORDERING INFORMATION

Ordering Number		Package	Pin Assignment			Packing
Lead Free	Halogen Free		1	2	3	
UH8102AL-AE3-R	UH8102AG-AE3-R	SOT-23	O	I	G	Tape Reel
UH8102BL-AE3-R	UH8102BG-AE3-R	SOT-23	O	I	G	Tape Reel
UH8102BL-G03-B	UH8102BG-G03-B	SIP-3	I	G	O	Tape Box
UH8102BL-G03-K	UH8102BG-G03-K	SIP-3	I	G	O	Bulk

Note: O: Output, I: V_{DD}, G: Gnd

UH8102XL-AE3-R	(1) Packing Type	(1) B: Tape Box, K: Bulk, R: Tape Reel
	(2) Package Type	(2) AE3:SOT-23, G03: SIP-3
	(3) Halogen Free	(3) L: Lead Free, G: Halogen Free
	(4) Magnetic Perform	(4) A: LOW, B: HIGH

MARKING (For SOT-23)

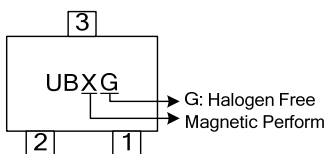

■ PIN CONFIGURATION

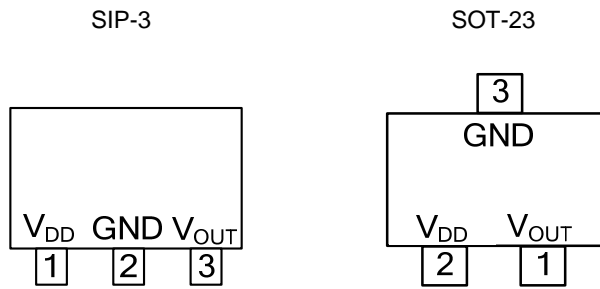

■ PIN DESCRIPTION

PIN NAME	PIN TYPE	PIN DESCRIPTION
V_{OUT}	O	Digital Output
V_{DD}	P	Power Supply
GND	G	Ground

Note: O=Output, P=Power Supply, G=Ground

■ BLOCK DIAGRAM

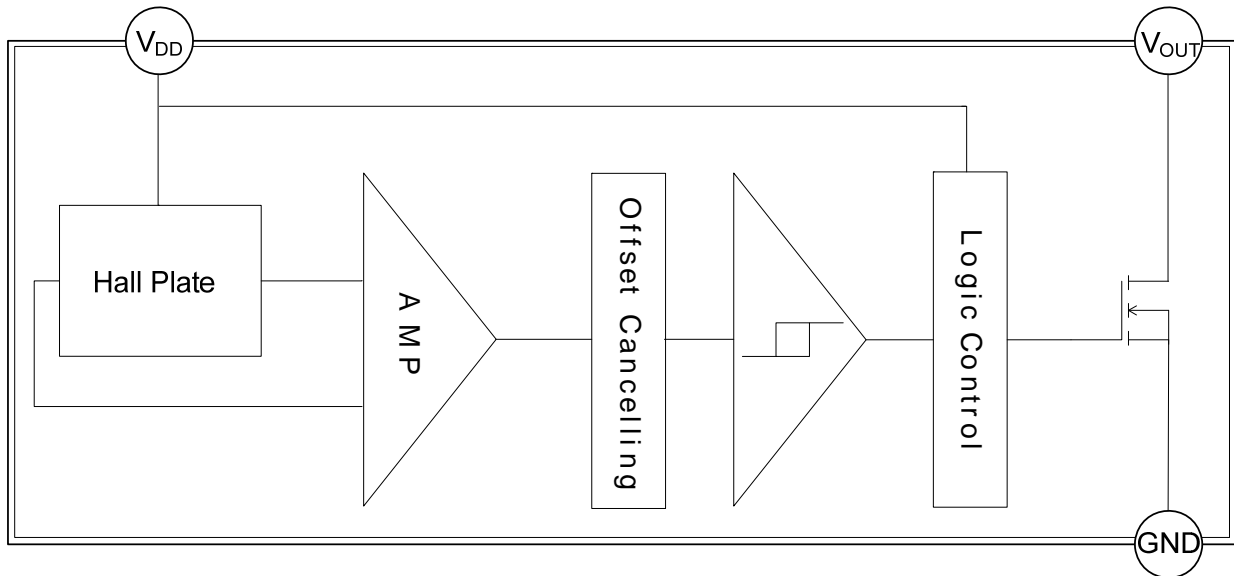

■ ABSOLUTE MAXIMUM RATING

PARAMETER	SYMBOL	RATINGS	UNIT
Magnetic Flux Density	B	Unlimited	mT
Supply Voltage	V _{DD}	5.5	V
Supply current	I _Q	-1 ~ +2.5	mA
Power Dissipation	SIP-3	P _D	400
	SOT-23		200
Junction Temperature	T _J	150	°C
Operation Temperature	T _{OPR}	-40 ~ +85	°C
Storage Temperature	T _{STG}	-40 ~ +150	°C

Note: Absolute maximum ratings are those values beyond which the device could be permanently damaged.

Absolute maximum ratings are stress ratings only and functional device operation is not implied.

■ RECOMMENDED OPERATING CONDITIONS (T_A=25°C)

PARAMETER	SYMBOL	CONDITIONS	MIN	TYP	MAX	UNIT
Supply Voltage	V _{DD}	Operating	2.4	2.7	5.5	V
Output Voltage	V _{OUT}		-0.3	2.7	5.5	V
Ambient Temperature	T _A		-40	25	85	°C

■ ELECTRICAL CHARACTERISTICS (T_A=25°C)

PARAMETER	SYMBOL	CONDITIONS	MIN	TYP	MAX	UNIT	
Output Saturation Voltage	V _{SAT}	V _{DD} =2.7V		0.1		V	
Output Leakage Current	I _{OFF}			0.01		µA	
Supply Current	I _{DD(EN)}	V _{DD} =2.7V	Chip enable			1.1	mA
	I _{DD(DIS)}		Chip disable			2.5	µA
	I _{DD(AVG)}		Average supply current			3	20
Operating Time	T _{OP}	V _{DD} =2.7V		60		µs	
Standby Time	T _{SD}			150		ms	
Duty Cycle	D.C.			0.04		%	

■ MAGNETIC CHARACTERISTICS (T_A=25°C, V_{DD}=2.7V)

For UH8102A (LOW level when no magnetic field is applied)

Rank 1

PARAMETER	SYMBOL	TEST CONDITIONS	MIN	TYP	MAX	UNIT
Operation Points	B _{OP}	South or North pole to branded side, B < B _{OP} , V _{out} On	7	15	25	Gauss
Release Points	B _{RP}	South or North pole to branded side, B > B _{RP} , V _{out} Off	15	25	35	
Hysteresis	B _{OP} -B _{RP}	B _{OPX} -B _{RPX}	5	10	15	

Rank 2

PARAMETER	SYMBOL	TEST CONDITIONS	MIN	TYP	MAX	UNIT
Operation Points	B _{OP}	South or North pole to branded side, B < B _{OP} , V _{out} On	7		50	Gauss
Release Points	B _{RP}	South or North pole to branded side, B > B _{RP} , V _{out} Off	15		70	
Hysteresis	B _{OP} -B _{RP}	B _{OPX} -B _{RPX}	5		50	

■ MAGNETIC CHARACTERISTICS(Cont.)

For UH8102B (HIGH level when no magnetic field is applied)

Rank 1

PARAMETER	SYMBOL	TEST CONDITIONS	MIN	TYP	MAX	UNIT
Operation Points	$ B_{OP} $	South or North pole to branded side, $ B > B_{OP} $, Vout On	15	25	35	Gauss
Release Points	$ B_{RP} $	South or North pole to branded side, $ B < B_{RP} $, Vout Off	7	15	25	
Hysteresis	$ B_{OP}-B_{RP} $	$ B_{OPX}-B_{RPX} $	5	10	15	

Rank 2

PARAMETER	SYMBOL	TEST CONDITIONS	MIN	TYP	MAX	UNIT
Operation Points	$ B_{OP} $	South or North pole to branded side, $ B > B_{OP} $, Vout On	15		70	Gauss
Release Points	$ B_{RP} $	South or North pole to branded side, $ B < B_{RP} $, Vout Off	7		50	
Hysteresis	$ B_{OP}-B_{RP} $	$ B_{OPX}-B_{RPX} $	5		50	

■ TYPICAL APPLICATION CIRCUIT

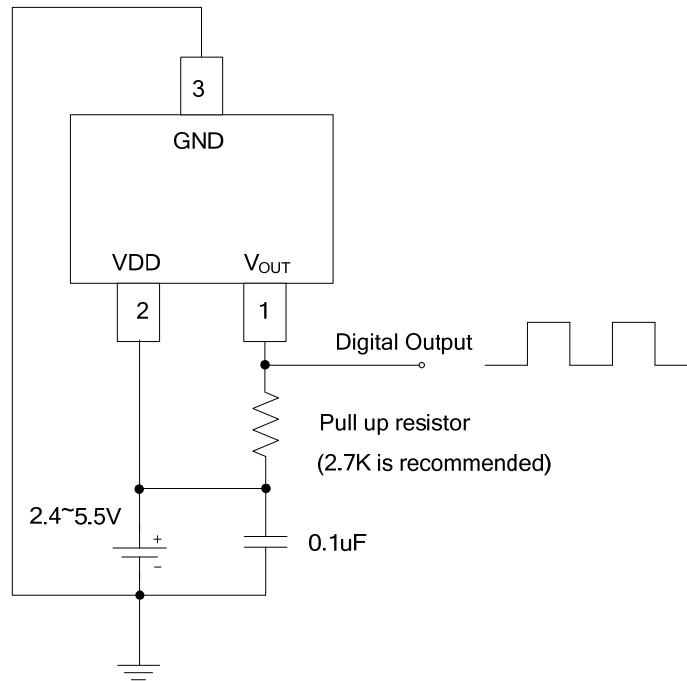

SIP-3

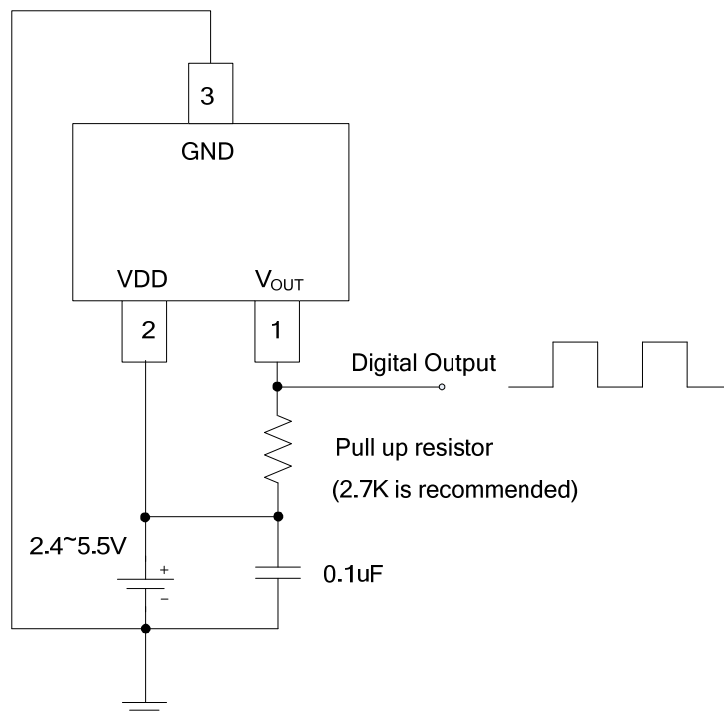

SOT-23

■ MAGNETIC FLUX

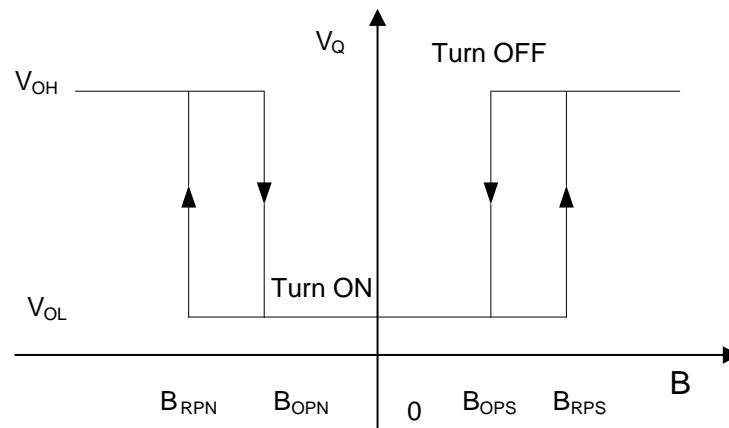

UH8102A (**LOW** level when no magnetic field is applied)

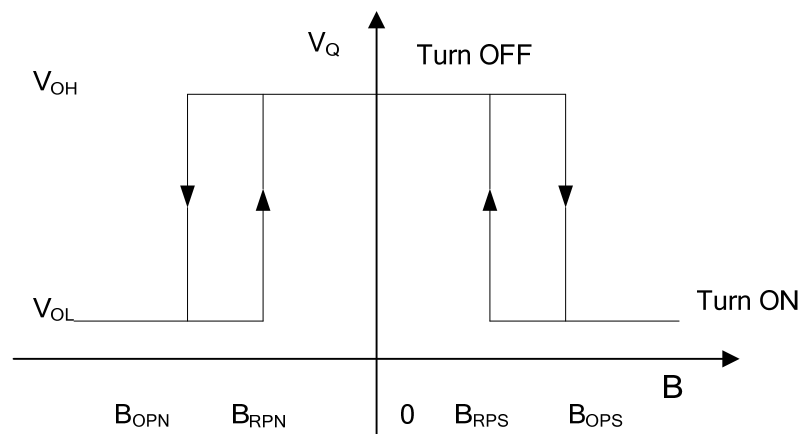

UH8102B (**HIGH** level when no magnetic field is applied)

UTC assumes no responsibility for equipment failures that result from using products at values that exceed, even momentarily, rated values (such as maximum ratings, operating condition ranges, or other parameters) listed in products specifications of any and all UTC products described or contained herein. UTC products are not designed for use in life support appliances, devices or systems where malfunction of these products can be reasonably expected to result in personal injury. Reproduction in whole or in part is prohibited without the prior written consent of the copyright owner. The information presented in this document does not form part of any quotation or contract, is believed to be accurate and reliable and may be changed without notice.