



UH378

LINEAR INTEGRATED CIRCUIT

COMPLEMENTARY OUTPUTS HALL EFFECT LATCH IC

DESCRIPTION

The UTC **UH378** is a Latch-Type Hall Effect sensor with built-in complementary output drivers. It's composed of internal temperature compensation circuit and built-in protection diode to prevent reverse power fault. It is aimed for brush-less DC Fan.

The outputs of the **UH378** operate as the Hysteresis Characteristics. The Outputs alternately switch between ON and OFF when either the magnetic flux density is larger than threshold B_{OP} or the magnetic flux density is lower than B_{RP} .

FEATURES

- * Widen Power Supply range from 3V ~ 20V.
- * On-chip Hall sensor with excellent hysteresis.
- * Build-in reverse protection diode.
- * TTL and MOS IC are directly drivable by the output
- * The life is semi permanent because it employs contact-less parts

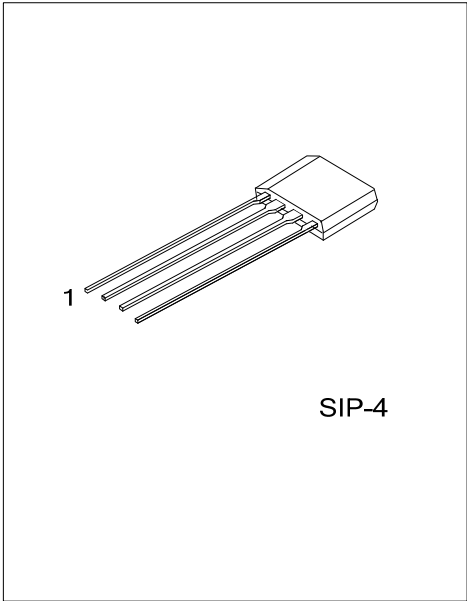

ORDERING INFORMATION

Ordering Number		Package	Packing
Lead Free	Halogen Free		
UH378L-x-G04-K	UH378G-x-G04-K	SIP-4	Bulk

UH378L-x-G04-K 	(1) Packing Type (2) Package Type (3) Magnetic characteristics (4) Lead Free	(1) K: Bulk (2) G04: SIP-4 (3) x: refer to Magnetic characteristics (4) G: Halogen Free, L: Lead Free
--------------------	---	--

PIN DESCRIPTION

PIN NO.	PIN NAME	P/I/O	DESCRIPTION
1	V_{CC}	P	Positive Power Supply
2	DO	O	Output Pin
3	DOB	O	Output Pin
4	V_{SS}	P	Ground

■ BLOCK DIAGRAM

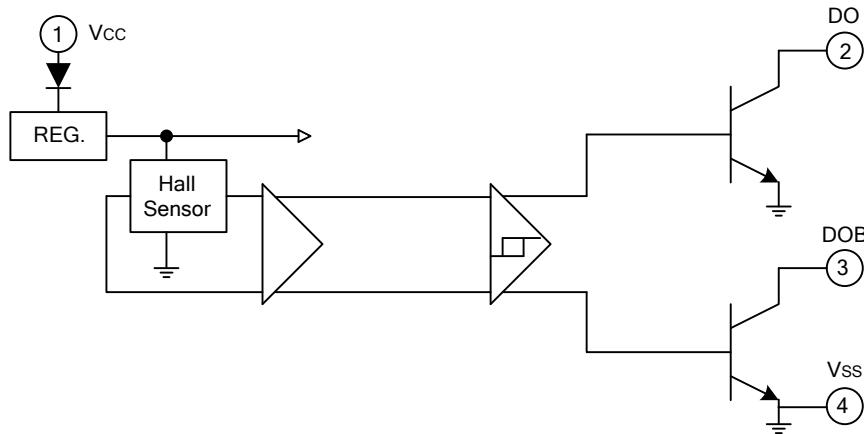

■ SENSOR LOCATIONS

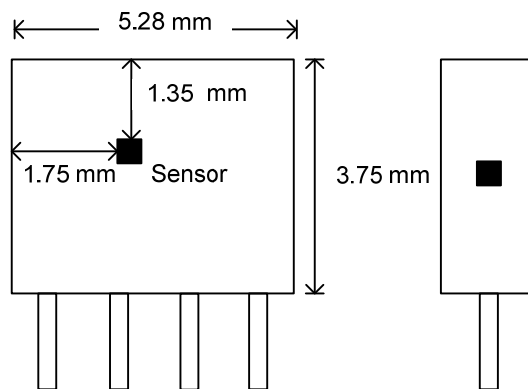

■ **ABSOLUTE MAXIMUM RATING** ($T_A = 25^\circ\text{C}$, unless otherwise specified)

PARAMETER	SYMBOL	RATINGS	UNIT
Supply Voltage	V_{CC}	20	V
Reverse V_{CC} Polarity Voltage	V_{RCC}	-25	V
Circuit Current	I_o	20	mA
Magnetic flux density	B	Unlimited	
Power Dissipation	P_D	500	mW
Junction Temperature	T_J	+150	$^\circ\text{C}$
Operating Temperature	T_{OPR}	-20 ~ +85	$^\circ\text{C}$
Storage Temperature	T_{STG}	-65 ~ +150	$^\circ\text{C}$

Note: Absolute maximum ratings are those values beyond which the device could be permanently damaged.

Absolute maximum ratings are stress ratings only and functional device operation is not implied.

■ **ELECTRICAL CHARACTERISTICS** ($T_A = 25^\circ\text{C}$, unless otherwise specified)

PARAMETER	SYMBOL	TEST CONDITIONS	MIN	TYP	MAX	UNIT
Low-Level Output Voltage	V_{OL}	$V_{CC} = 14\text{V}, I_{OUT}=5\text{mA}$		0.5	0.7	V
		$V_{CC} = 3.6\text{V}, I_{OUT}=5\text{mA}$		0.4	0.7	
Output Leakage Current	I_{CEX}	$V_{CC} = 14\text{V}$		1	10	μA
Supply Current	I_{CC}	$V_{CC} = 14\text{V}$		4.7	10	mA
		$V_{CC} = 3.6\text{V}$		4.6	10	
Output Switching Time	t_R	$V_{CC} = 14\text{V}, R_L=10\text{K}\Omega, C_L=10\text{pF}$			5	us
	t_F	$V_{CC} = 14\text{V}, R_L=10\text{K}\Omega, C_L=10\text{pF}$			2	

■ **MAGNETIC CHARACTERISTICS**

A grade

PARAMETR	SYMBOL	MIN	TYP	MAX	UNIT
Operate Point	B_{OP}	5		50	G
Release Point	B_{RP}	-50		-5	G
Hysteresis	B_{HYS}	20		100	G

B grade

PARAMETR	SYMBOL	MIN	TYP	MAX	UNIT
Operate Point	B_{OP}	5		70	G
Release Point	B_{RP}	-70		-5	G
Hysteresis	B_{HYS}	20		140	G

C grade

PARAMETR	SYMBOL	MIN	TYP	MAX	UNIT
Operate Point	B_{OP}			100	G
Release Point	B_{RP}	-100			G
Hysteresis	B_{HYS}	20		200	G

■ TEST CIRCUIT

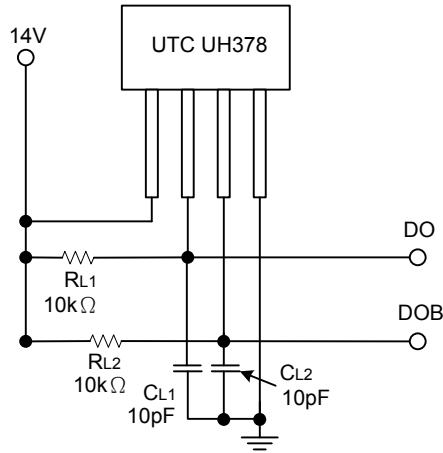

■ CHYSTERESIS CHARACTERISTICS

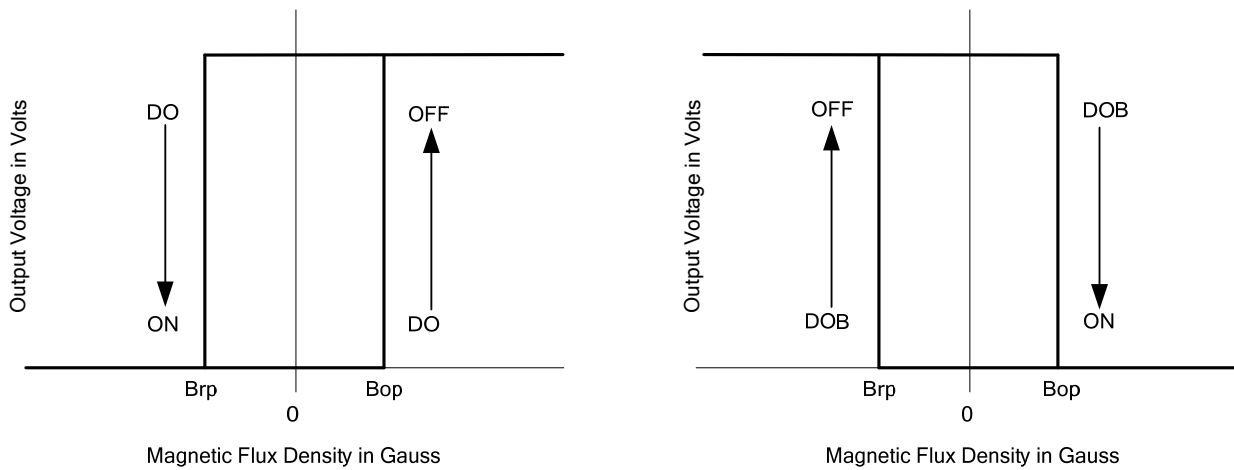

■ PERFORMANCE CHARACTERISTICS

$T_A(^{\circ}C)$	25	50	60	70	80	85	90	95	100	105	110	115	120
P_D (mW)	550	525	515	505	485	475	465	455	445	425	405	385	365

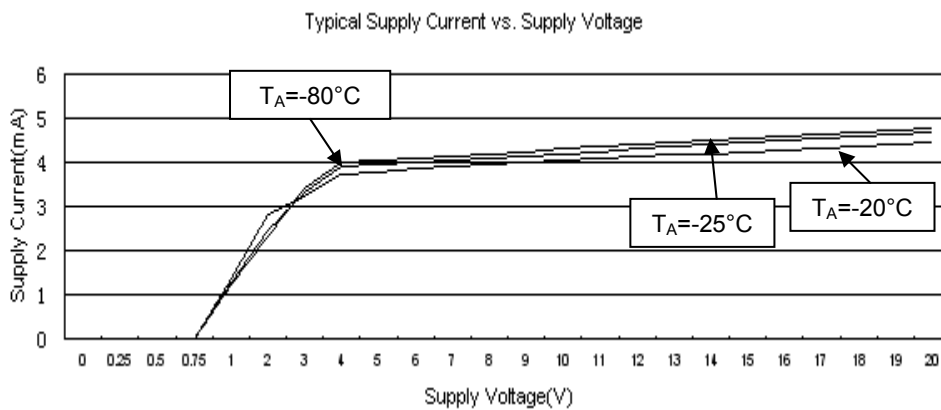
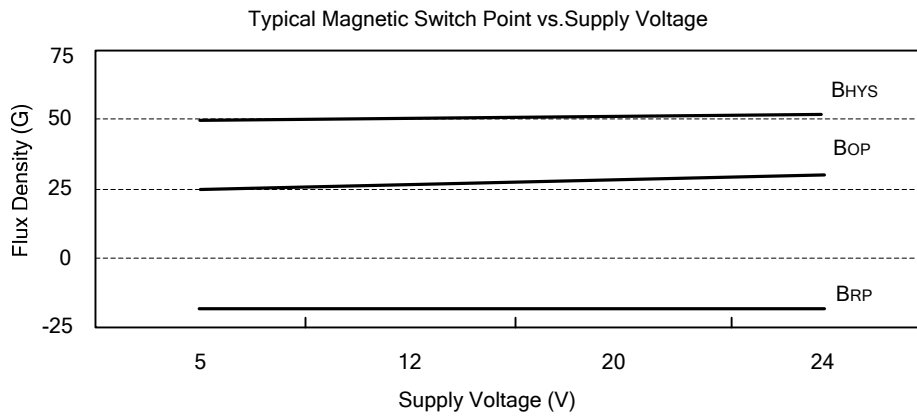
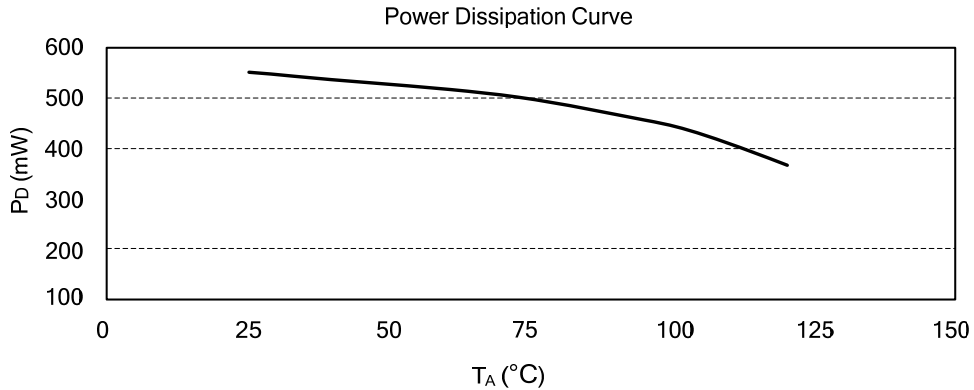

UTC assumes no responsibility for equipment failures that result from using products at values that exceed, even momentarily, rated values (such as maximum ratings, operating condition ranges, or other parameters) listed in products specifications of any and all UTC products described or contained herein. UTC products are not designed for use in life support appliances, devices or systems where malfunction of these products can be reasonably expected to result in personal injury. Reproduction in whole or in part is prohibited without the prior written consent of the copyright owner. The information presented in this document does not form part of any quotation or contract, is believed to be accurate and reliable and may be changed without notice.