



M3355

Preliminary

LINEAR INTEGRATED CIRCUIT

2-INPUT SINGLE VIDEO SWITCH

DESCRIPTION

The UTC M3355 is 2-input signal video switch selecting one of two video or audio signals. Its operating voltage is 4.75 ~ 13V and bandwidth is 10MHz. Crosstalk is 70dB (at 4.43MHz). It is applied to both NTSC and PAL VTR.

FEATURES

- * Operating Voltage: +4.75V ~ +13V
- * 2 Input-1 Output
- * Crosstalk 70dB (at 4.43MHz)

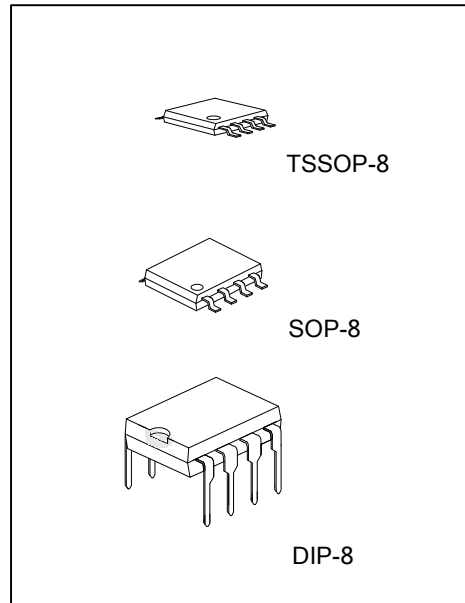

ORDERING INFORMATION

Ordering Number		Package	Packing
Lead Free	Halogen Free		
M3355L-S08-R	M3355G-S08-R	SOP-8	Tape Reel
M3355L-S08-T	M3355G-S08-T	SOP-8	Tube
M3355L-D08-T	M3355G-D08-T	DIP-8	Tube
M3355L-P08-R	M3355G-P08-R	TSSOP-8	Tape Reel

<p>M3355L-S08-R</p> <p>(1) Packing Type</p> <p>(2) Package Type</p> <p>(3) Lead Free</p>	<p>(1) R: Tape Reel, T: Tube</p> <p>(2) S08: SOP-8, D08: DIP-8, P08: TSSOP-8</p> <p>(3) G: Halogen Free, L: Lead Free</p>
--	---

■ EQUIVALENT CIRCUIT

PIN NO.	PIN NAME	INSIDE EQUIVALENT CIRCUIT
1	V _{IN1}	
2	SW1	
3	V _{IN2}	
4	NC	-
5	NC	-
6	V ⁺	-
7	V _{OUT}	
8	GND	-

■ ABSOLUTE MAXIMUM RATING (T_A=25°C)

PARAMETER		SYMBOL	RATINGS	UNIT
Supply Voltage		V ⁺	15	V
Power Dissipation	DIP-8	P _D	500	mW
	SOP-8		300	
	TSSOP-8		250	
Operating Temperature		T _{OPR}	-20~+75	°C
Storage Temperature		T _{STG}	-40~+125	°C

Note: Absolute maximum ratings are those values beyond which the device could be permanently damaged. Absolute maximum ratings are stress ratings only and functional device operation is not implied.

■ ELECTRICAL CHARACTERISTICS (V⁺=5V, T_A=25°C)

PARAMETER	SYMBOL	TEST CONDITIONS	MIN	TYP	MAX	UNIT
Operating Voltage	V ⁺		4.75		13.0	V
Operating Current	I _{CC}	S1=S2=S3=1		8.5	11.0	mA
Frequency Characteristic (1)	G11	V _i =2.5V _{pp} , V _o (20Hz)/V _o (100kHz)		0	±1.0	dB
Frequency Characteristic (2)	G12	V _i =2.0V _{pp} , V _o (10MHz)/V _o (100kHz)		0	±1.0	dB
Voltage Gain	G _v	V _i =2.5V _{pp} , 100kHz, V _o /V _i	-0.5	0		dB
Total Harmonic Distortion	THD	V _i =2.5V _{pp} , 1kHz		0.01		%
Differential Gain	DG	V _i =2V _{pp} standard staircase signal		0		%
Differential Phase	DP	V _i =2V _{pp} standard staircase signal		0		deg
Output Offset Voltage	V _{off}	S1=S2=1, S3=1~2, V _o voltage change		0	±15	mV
Crosstalk	CT	(S1=S3=1, S2=2) and (S1=S3=2, S2=1), V _i =2.0V _{p-p} , 4.43MHz, V _o /V _i		-70		dB
Switch Change Voltage	V _{CH}	Garanteed voltage of all switch on	2.4			V
	V _{CL}	Garanteed voltage of all switch off			0.8	
Input Impedance	R _I			15		kΩ
Output impedance	R _O			10		Ω

■ **CONTROL SIGNAL-OUTPUT SIGNAL**

SW1	OUTPUT SIGNAL
L	Vin 1
H	Vin 2

■ **APPLICATION**

Oscillation Prevention on light loading conditions
 Recommended under circuit

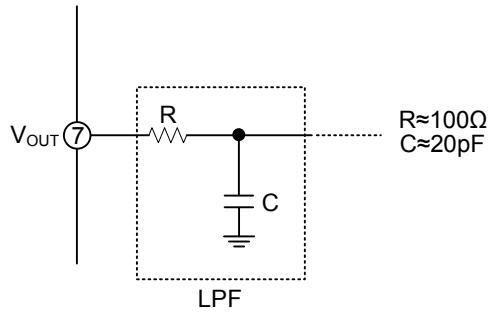

This IC requires 0.1μF capacitor between INPUT and GND for bias type input at mute mode

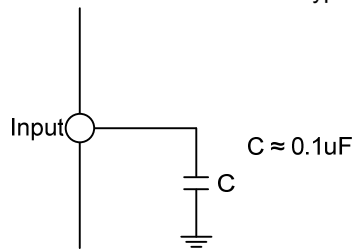

■ TEST CIRCUIT

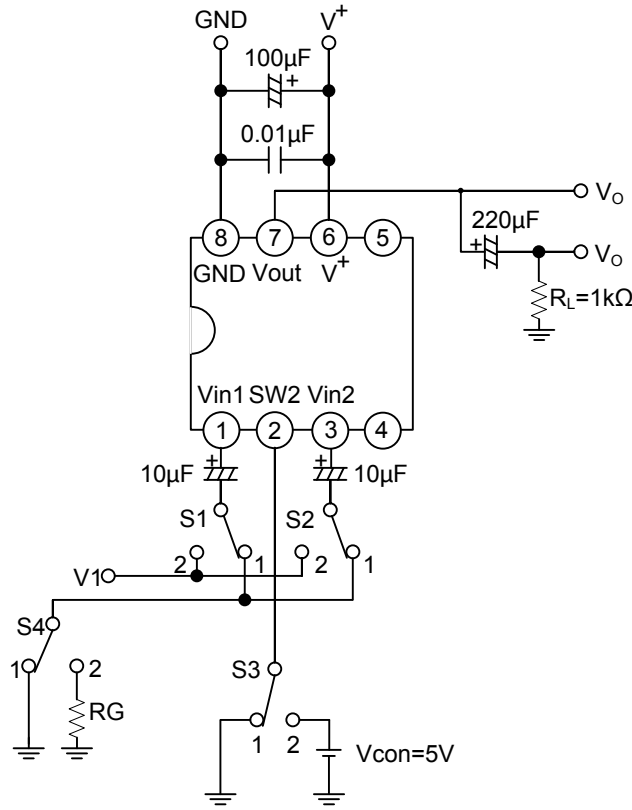

■ DC VOLTAGE EACH TERMINAL (Typ. on Test Circuit $T_A=25^\circ\text{C}$)

Terminal Name	V_{IN1}	SW1	V_{IN2}	V^+	V_{OUT}	GND
DC Voltage	$\frac{3}{5}V^+$		$\frac{3}{5}V^+$		$\frac{3}{5}V^+ - 0.7$	

UTC assumes no responsibility for equipment failures that result from using products at values that exceed, even momentarily, rated values (such as maximum ratings, operating condition ranges, or other parameters) listed in products specifications of any and all UTC products described or contained herein. UTC products are not designed for use in life support appliances, devices or systems where malfunction of these products can be reasonably expected to result in personal injury. Reproduction in whole or in part is prohibited without the prior written consent of the copyright owner. The information presented in this document does not form part of any quotation or contract, is believed to be accurate and reliable and may be changed without notice.