



LM4862

Preliminary

CMOS IC

AUDIO POWER AMPLIFIER WITH SHUTDOWN MODE

DESCRIPTION

The UTC **LM4862** is a built in bridge-connected form audio amplifier. In normal operation, it can deliver 500 mW (typ.) continuous power. The output load of the UTC **LM4862** should be 8Ω, the supply voltage should be 5V, and the THD is as low as 1%.

As the most popular amplifiers, **LM4862** is also designed to be able to provide high quality output power with less external components, such as the output capacitors for coupling, bootstrap capacitors, or snobbery networks.

In applications, the UTC **LM4862** can be specially used as an ideal in low-power portable systems, for example, portable computers, desktop computers, and low voltage audio systems, etc.

FEATURES

- * Stable Unity Gain
- * Gain Configuration can be set by External Components

ORDERING INFORMATION

Ordering Number		Package	Packing
Lead Free	Halogen Free		
LM4862L-D08-T	LM4862G-D08-T	DIP-8	Tube
LM4862L-S08-R	LM4862G-S08-R	SOP-8	Tape Reel

<p>LM4862L-D08-T</p> <p>(1)Packing Type (2)Package Type (3)Lead Free</p>	<p>(1) R: Tape Reel, T: Tube (2) D08: DIP-8, S08: SOP-8 (3) G: Halogen Free, L: Lead Free</p>
----------------------------------------------------------------------------------	-------------------------------------------------------------------------------------------------------

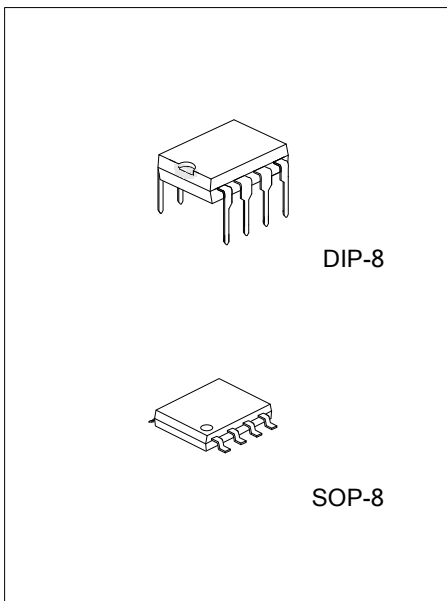

■ PIN CONFIGURATION

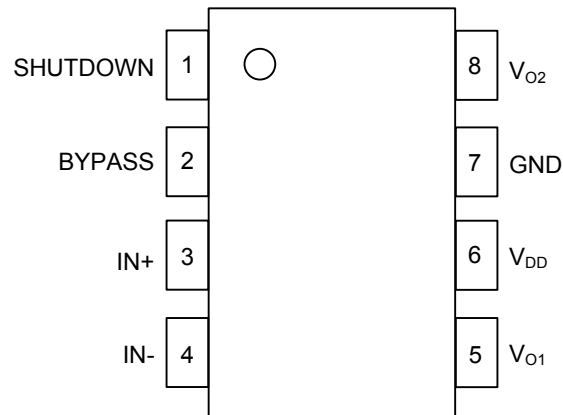

■ PIN DESCRIPTION

PIN NO	PIN NAME	DESCRIPTION
1	SHUTDOWN	Shutdown mode control input, high active
2	BYPASS	Connect to internal voltage divider for middle supply bias
3	IN+	Non-inverting power input pin
4	IN-	Inverting power input pin
5	V _{O1}	Output power pin 1
6	V _{DD}	Power supply
7	GND	Ground
8	V _{O2}	Output power pin 2

■ BLOCK DIAGRAM

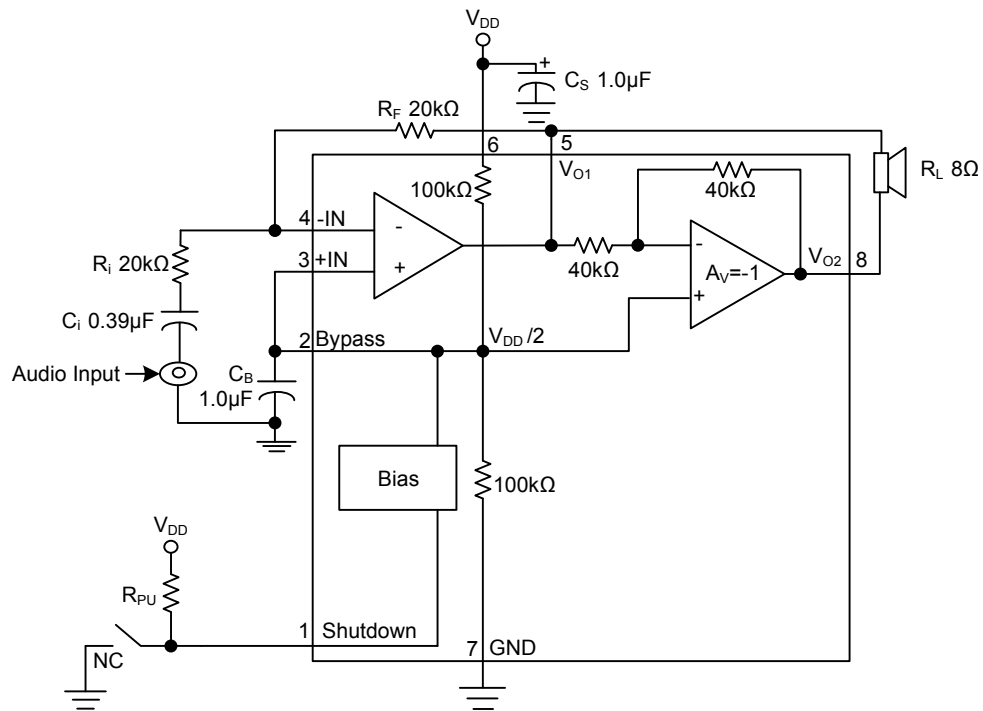

■ **ABSOLUTE MAXIMUM RATING** ($T_a=25^\circ\text{C}$ unless otherwise specified.)

PARAMETER	SYMBOL	RATINGS	UNIT	
Supply Voltage	V_{DD}	6.0	V	
Input Voltage	V_{IN}	-0.3 ~ +(0.3+ V_{DD})	V	
Power Dissipation	DIP-8	P_D	500	mW
	SOP-8		300	mW
Infrared (15 sec.)		220	$^\circ\text{C}$	
Junction Temperature	T_J	+150	$^\circ\text{C}$	
Storage Temperature	T_{STG}	-65 ~ +150	$^\circ\text{C}$	

Note: Absolute maximum ratings are those values beyond which the device could be permanently damaged.

Absolute maximum ratings are stress ratings only and functional device operation is not implied.

■ **ELECTRICAL CHARACTERISTICS** ($V_{CC}=5\text{V}$, $f=1\text{kHz}$, $T_a=25^\circ\text{C}$ unless otherwise specified.)

PARAMETER	SYMBOL	TEST CONDITIONS	MIN	TYP	MAX	UNIT
Supply Voltage	V_{DD}		2.0		5.5	V
Output Offset Voltage	V_{OS}	$V_{IN}=0\text{V}$		5.0	50	mV
Quiescent Power Supply Current	I_{DD}	$V_{IN}=0\text{V}$, $I_O=0\text{A}$		6.5	12.0	mA
Shutdown Current	I_{SD}	$V_{PIN1}=V_{DD}$		0.6		μA
Output Power	P_O	THD=1%, $f=1\text{kHz}$, $R_L=8\Omega$		500		mW
		THD=10%, $f=1\text{kHz}$, $R_L=8\Omega$		800		mW
Total Harmonic Distortion	THD	$f=1\text{kHz}$, $R_L=8\Omega$, $P_O = 500\text{mW}$		0.5		%
Power Supply Rejection Ratio	PSRR	$V_{CC}=4.9\text{V} \sim 5.1\text{V}$		60		dB

UTC assumes no responsibility for equipment failures that result from using products at values that exceed, even momentarily, rated values (such as maximum ratings, operating condition ranges, or other parameters) listed in products specifications of any and all UTC products described or contained herein. UTC products are not designed for use in life support appliances, devices or systems where malfunction of these products can be reasonably expected to result in personal injury. Reproduction in whole or in part is prohibited without the prior written consent of the copyright owner. The information presented in this document does not form part of any quotation or contract, is believed to be accurate and reliable and may be changed without notice.