



PA4819

CMOS IC

350mW AUDIO POWER AMPLIFIER WITH SHUTDOWN MODE

DESCRIPTION

As a mono bridged power amplifier which is operating on a single 5V supply, the UTC **PA4819** is capable of delivering 350mW_{RMS} of output power per channel into 16Ω loads with less than 10% THD+N and also delivering 300mW_{RMS} of output power per channel into 8Ω loads with less than 10% THD+N.

The UTC **PA4819** is optimally suited for low-power portable applications because of the it do not require output coupling capacitors, bootstrap capacitors or snubber networks.

By using external gain-setting resistors, the closed loop response of the unity-gain stable **PA4819** can be configured.

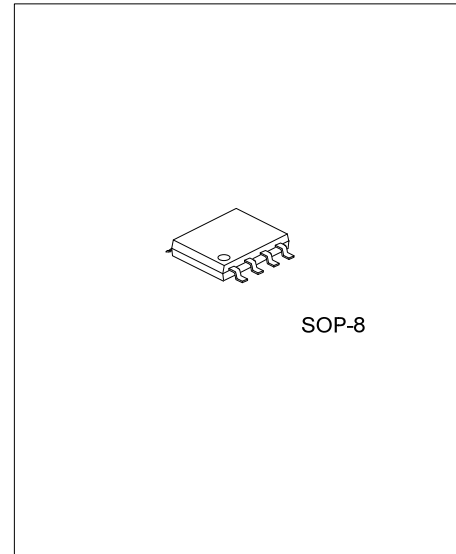

Lead-free: PA4819L
Halogen-free: PA4819G

FEATURES

- * Output power at 10% THD+N
Supply voltage:5V
Delivering 350mW_{RMS} into a 16Ω load
Delivering 300mW_{RMS} into a 8Ω load
- * With shutdown mode
- * Stable unity-gain.

ORDERING INFORMATION

Ordering Number			Package	Packing
Normal	Lead Free	Halogen Free		
PA4819-S08-R	PA4819L-S08-R	PA4819G-S08-R	SOP-8	Tape Reel
PA4819-S08-T	PA4819L-S08-T	PA4819G-S08-T	SOP-8	Tube

<p>PA4819L-S08-R</p> <p>(1)Packing Type</p> <p>(2)Package Type</p> <p>(3)Lead Plating</p>	<p>(1) R: Tape Reel, T: Tube</p> <p>(2) S08: SOP-8</p> <p>(3) G: Halogen Free, L: Lead Free, Blank: Pb/Sn</p>
---	---

■ PIN CONFIGURATION

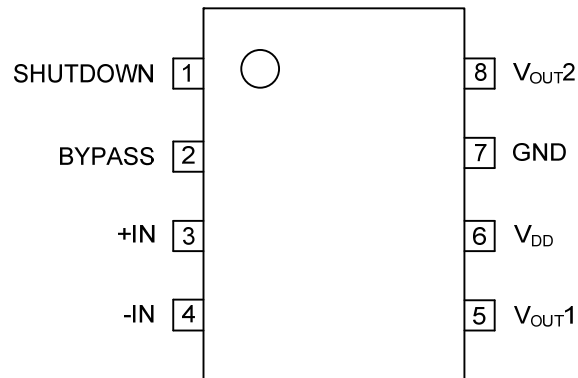

■ PIN DESCRIPTION

PIN NO.	PIN NAME	I/O	PIN DESCRIPTION
1	SHUTDOWN	I	Shutdown control input pin.
2	BYPASS		Connected to a bypass capacitor.
3	+IN	I	+ pin of input signal.
4	-IN	I	- pin of input signal.
5	V _{OUT1}	O	Output pin1
6	V _{DD}		Supply voltage
7	GND		GND
8	V _{OUT2}	O	Output pin2

■ ABSOLUTE MAXIMUM RATING

PARAMETER	SYMBOL	RATINGS	UNIT
Supply Voltage	V_{CC}	6	V
Input Voltage	V_{IN}	-0.3~ V_{DD} +0.3	V
Power Dissipation	P_D	Internally Limited	W
Junction Temperature	T_J	150	°C
Operating Temperature	T_{OPR}	-40~+85	°C
Storage Temperature	T_{STG}	-65~+150	°C

Note: Absolute maximum ratings are those values beyond which the device could be permanently damaged.
Absolute maximum ratings are stress ratings only and functional device operation is not implied.

■ THERMAL DATA

PARAMETER	SYMBOL	MIN	TYP	MAX	UNIT
Junction to Ambient	θ_{JA}			170	°C/W
Junction to Case	θ_{JC}			35	°C/W

■ ELECTRICAL CHARACTERISTICS ($T_A=25^\circ\text{C}$, $R_L=16\Omega$, unless otherwise specified)

PARAMETER	SYMBOL	TEST CONDITIONS	MIN	TYP	MAX	UNIT
FOR $V_{DD}=3V$						
Supply Voltage	V_{DD}		2.0	5	5.5	V
Shutdown voltage Input High-Level	V_{SDIH}		2.4			V
Shutdown voltage Input Low-Level	V_{SDIL}				0.6	V
DC Differential Output Voltage	$V_{OUT(DIFF)}$	$V_{IN}=0V$		5	50	mV
Supply Current	Mute Mode	$V_{IN}=0V, I_{OUT}=0A$ $V_{PIN1}=V_{DD}$		1.0	3.0	mA
	Shutdown Mode			0.7	5	μA
Output Power	P_{OUT}	THD=10%, $f_{IN}=1\text{kHz}$, $R_L=16\Omega$,		110		mW
		THD=10%, $f_{IN}=1\text{kHz}$, $R_L=8\Omega$,		90		
Total Harmonic Distortion+Noise	THD+N	$P_{OUT}=80\text{mW}_{RMS}$, $f_{IN}=1\text{kHz}$, $G=2V/V$		1		%
FOR $V_{DD}=5V$						
Supply Voltage	V_{DD}		2.0	5	5.5	V
Shutdown voltage Input High-Level	V_{SDIH}		4			V
Shutdown voltage Input Low-Level	V_{SDIL}				1	V
DC Differential Output Voltage	$V_{OUT(DIFF)}$	$V_{IN}=0V$		5	50	mV
Supply Current	Mute Mode	$V_{IN}=0V, I_{OUT}=0A$ $V_{PIN1}=V_{DD}$		1.5	3.0	mA
	Shutdown Mode			1	5	μA
Output Power	P_{OUT}	THD=10%, $f_{IN}=1\text{kHz}$, $R_L=16\Omega$,		350		mW
		THD=10%, $f_{IN}=1\text{kHz}$, $R_L=8\Omega$,		300		
Total Harmonic Distortion+Noise	THD+N	$P_{OUT}=270\text{mW}_{RMS}$, $f_{IN}=1\text{kHz}$, $G=2V/V$		1		%

■ BLOCK DIAGRAM

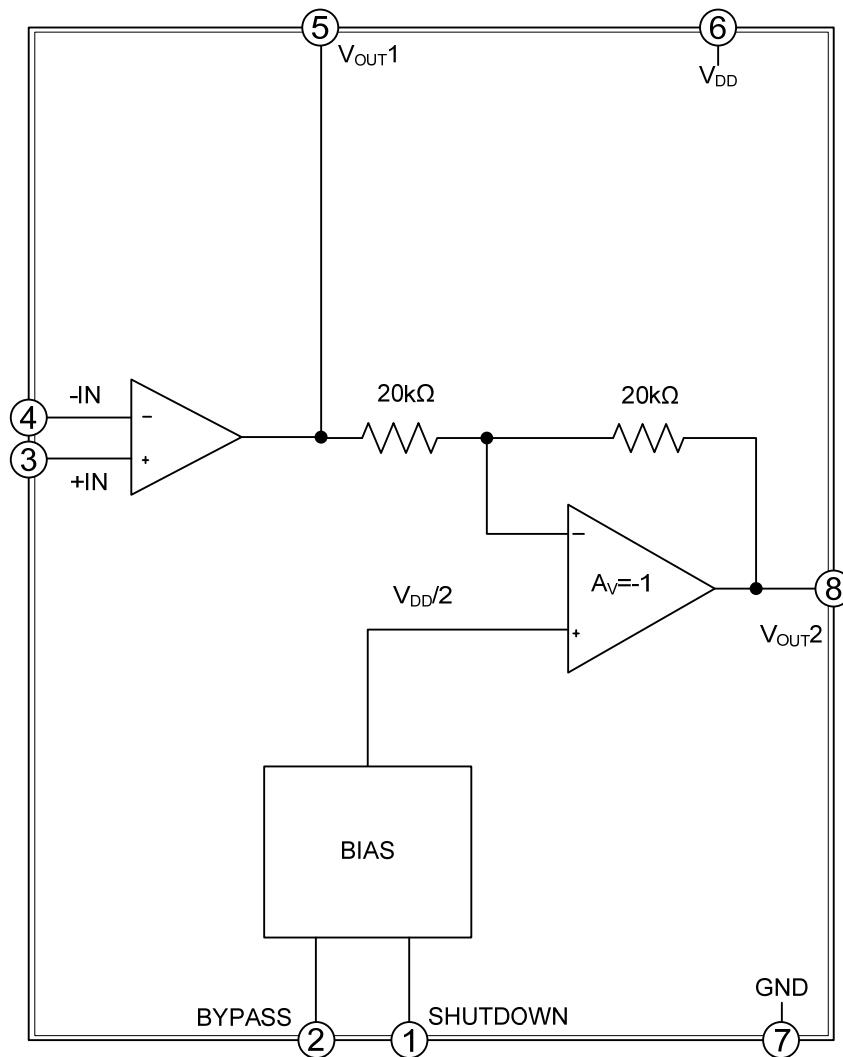

■ TYPICAL APPLICATION CIRCUIT

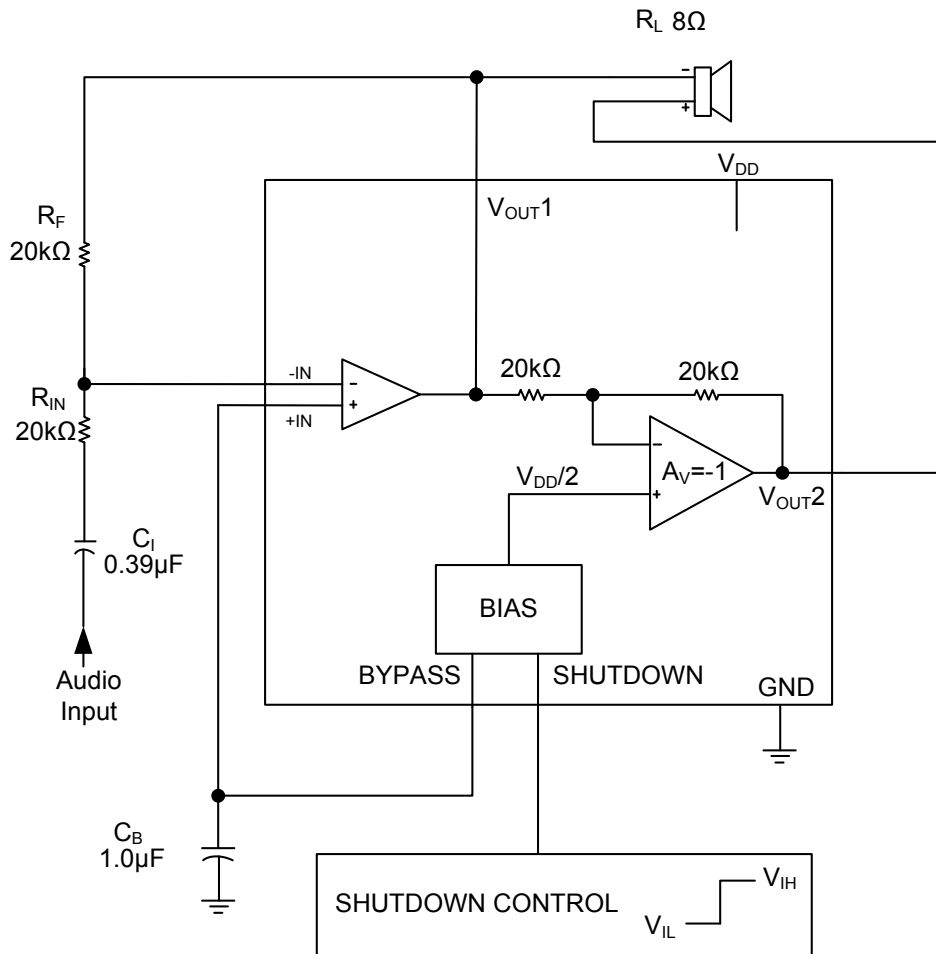

■ TYPICAL CHARACTERISTICS

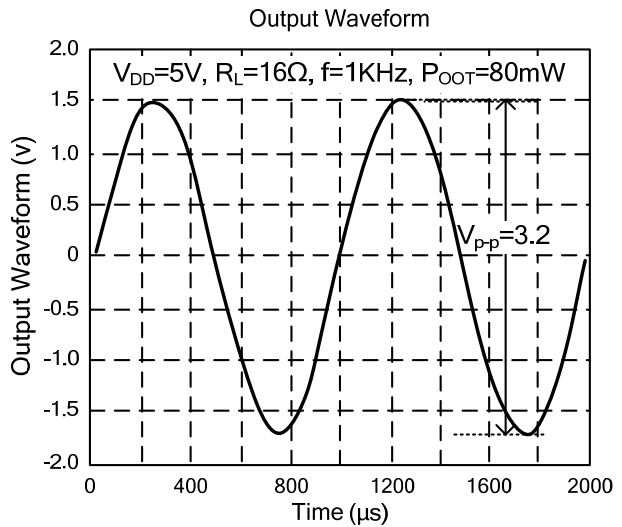
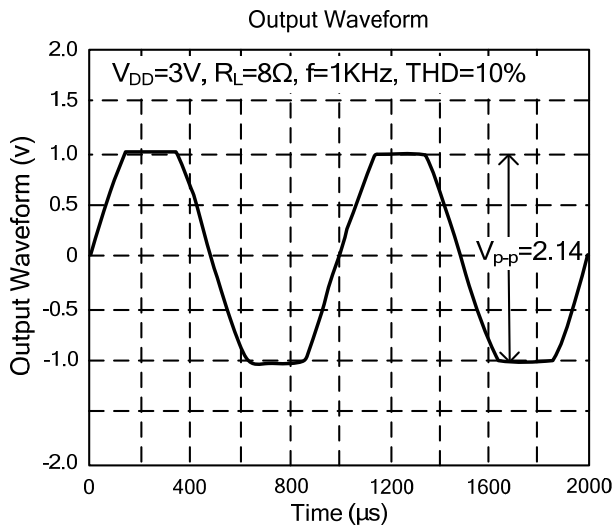
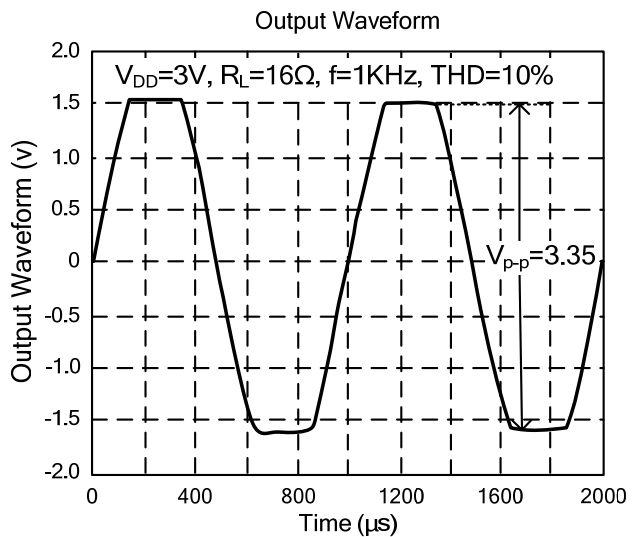
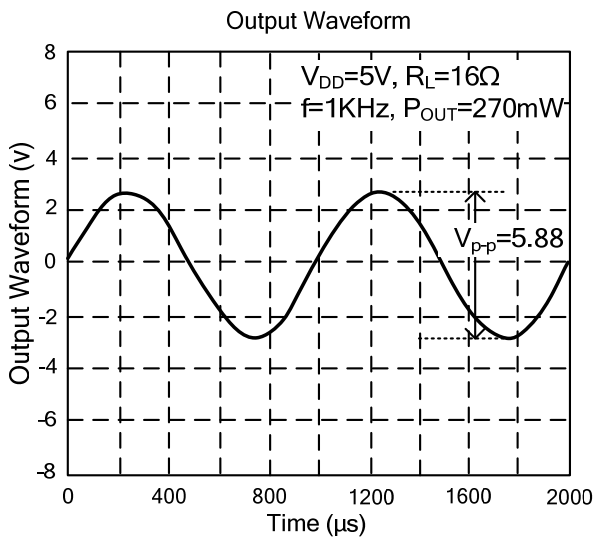
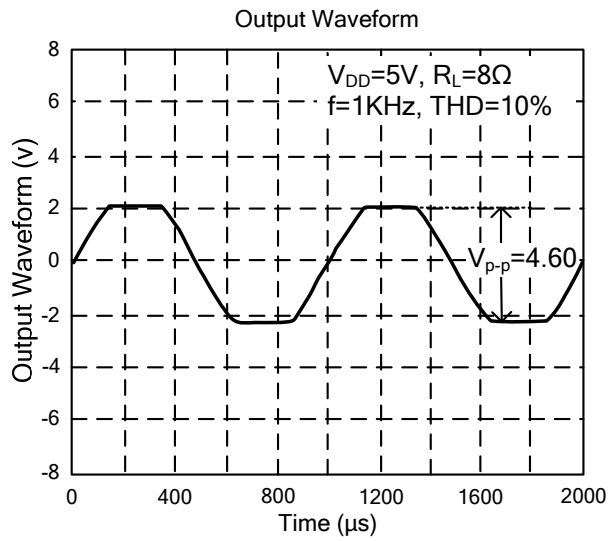
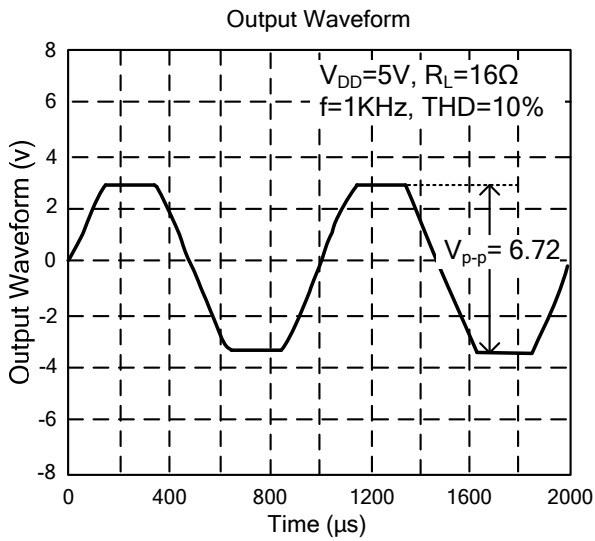

UTC assumes no responsibility for equipment failures that result from using products at values that exceed, even momentarily, rated values (such as maximum ratings, operating condition ranges, or other parameters) listed in products specifications of any and all UTC products described or contained herein. UTC products are not designed for use in life support appliances, devices or systems where malfunction of these products can be reasonably expected to result in personal injury. Reproduction in whole or in part is prohibited without the prior written consent of the copyright owner. The information presented in this document does not form part of any quotation or contract, is believed to be accurate and reliable and may be changed without notice.