



# UCD4066

CMOS IC

## QUAD BILATERAL SWITCH

### DESCRIPTION

The UTC **UCD4066** is a quad bilateral switch which can be applied for switching of analog signals and digital signals. When control input CONT is set to "H" level, the impedance between input and output of the switch becomes low and when it is set to "L" level, the impedance becomes high. It has a much lower "ON" resistance, and "ON" resistance is relatively constant over the input-signal range.

### FEATURES

- \* 15V Digital or ±7.5V Peak-to-Peak Switching
- \* 85-Ω Typical On-State Resistance for 15V Operation
- \* High noise immunity 0.45 V<sub>DD</sub> (typ.)
- \* Matched "ON" resistance ΔR<sub>ON</sub>=5Ω (typ.) over 15V signal input
- \* High degree linearity 0.1% distortion (typ.)  
@ f<sub>IS</sub>=1kHz, V<sub>IS</sub>=5V<sub>P-P</sub>, V<sub>DD</sub>-V<sub>SS</sub>=5V, R<sub>L</sub>=10kΩ
- \* Extremely low "OFF" 0.1nA (typ.)  
switch leakage: @ V<sub>DD</sub>-V<sub>SS</sub>=10V, T<sub>A</sub>=25°C
- \* Extremely high control input impedance 10<sup>12</sup>Ω (typ.)
- \* Frequency response, switch "ON" 40 MHz (typ.)

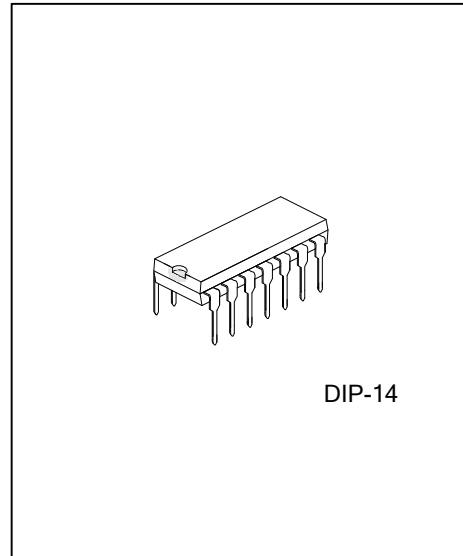

### ORDERING INFORMATION

Ordering Number		Package	Packing
Lead Free	Halogen Free		
UCD4066L-D14-T	UCD4066G-D14-T	DIP-14	Tube

<p>UCD4066L-D14-T</p> <ul style="list-style-type: none"> <li>(1) Packing Type</li> <li>(2) Package Type</li> <li>(3) Lead Free</li> </ul>	<ul style="list-style-type: none"> <li>(1) T: Tube</li> <li>(2) D14: DIP-14</li> <li>(3) L: Lead Free, G: Halogen Free</li> </ul>
---	---

## ■ PIN CONFIGURATION

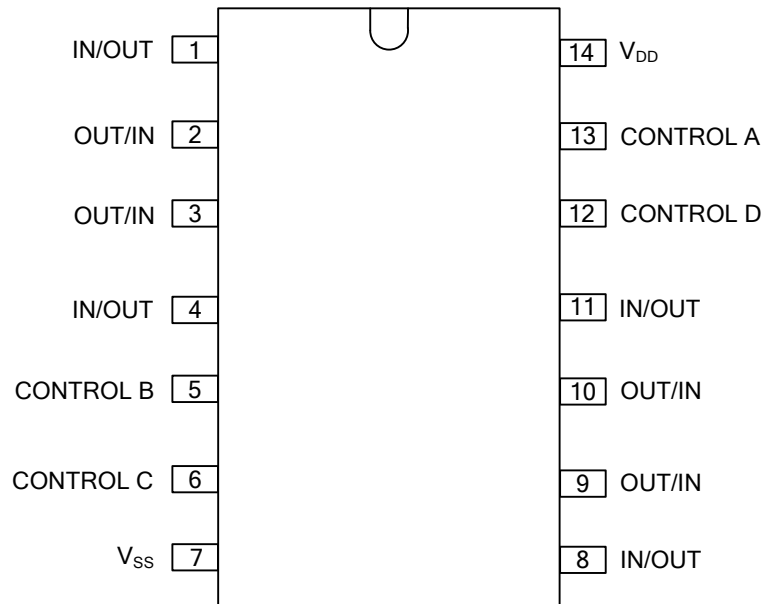

## ■ PIN DESCRIPTION

PIN NO.	PIN NAME	DESCRIPTION
1	IN/OUT	Signal IN/OUT A
2	OUT/IN	Signal OUT/IN A
3	OUT/IN	Signal OUT/IN B
4	IN/OUT	Signal IN/OUT B
5	CONTROL B	CONTROL B
6	CONTROL C	CONTROL C
7	V <sub>SS</sub>	Ground
8	IN/OUT	Signal IN/OUT C
9	OUT/IN	Signal OUT/IN C
10	OUT/IN	Signal OUT/IN D
11	IN/OUT	Signal IN/OUT D
12	CONTROL D	CONTROL D
13	CONTROL A	CONTROL A
14	V <sub>DD</sub>	Power supply

■ BLOCK DIAGRAM

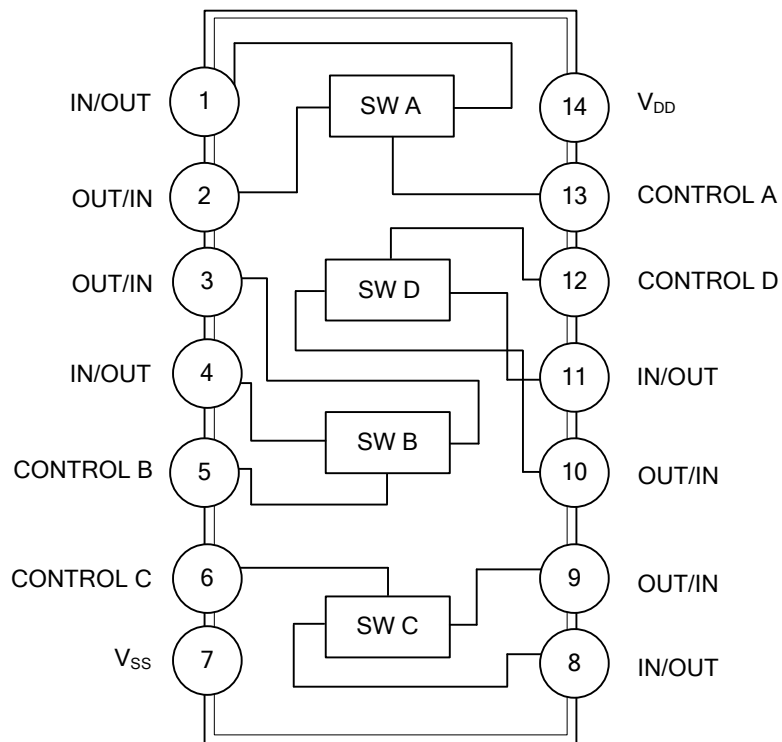

■ SCHEMATIC DIAGRAM

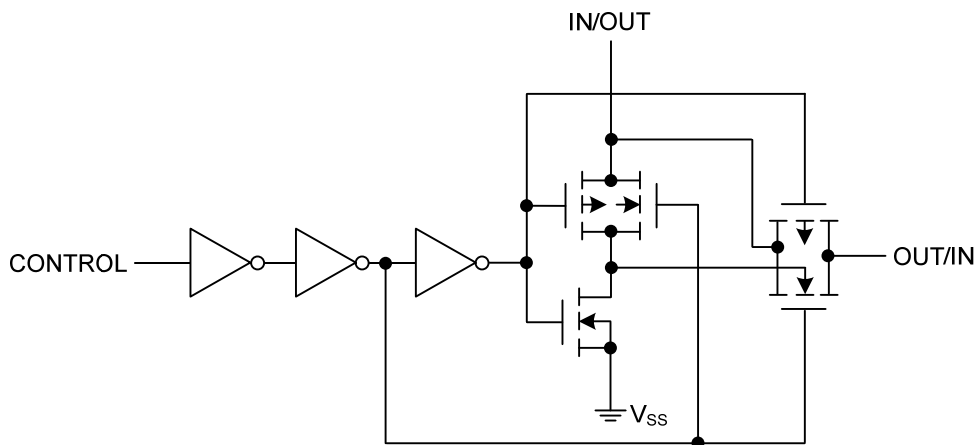

■ **ABSOLUTE MAXIMUM RATING** ( $V_{SS}=0V$  unless otherwise specified.)

PARAMETER	SYMBOL	RATINGS	UNIT
Supply Voltage	$V_{DD}$	-0.5~+18	V
Input Voltage	$V_{IN}$	-0.5~ $V_{CC}+0.5$	V
Power Dissipation	$P_D$	700	mW
Storage Temperature	$T_{STG}$	-65~+150	°C

■ **RECOMMENDED OPERATING CONDITIONS** ( $V_{SS}=0V$  unless otherwise specified.)

PARAMETER	SYMBOL	RATINGS	UNIT
Supply Voltage	$V_{DD}$	3~15	V
Input Voltage	$V_{IN}$	0~ $V_{DD}$	V
Operating Temperature	$T_A$	-40~+85	°C

Note: Absolute maximum ratings are those values beyond which the device could be permanently damaged.  
 Absolute maximum ratings are stress ratings only and functional device operation is not implied.

■ **DC ELECTRICAL CHARACTERISTICS** ( $T_A=+25^{\circ}C$ ,  $V_{SS}=0V$  unless otherwise specified.)

PARAMETER	SYMBOL	TEST CONDITIONS	MIN	TYP	MAX	UNIT
Quiescent Device Current	$I_{DD}$	$V_{IN}=V_{DD}$	$V_{DD}=5V$	0.01	1.0	$\mu A$
			$V_{DD}=10V$	0.01	2.0	
			$V_{DD}=15V$	0.01	4.0	
<b>SINGAL INPUTS AND OUTPUTS</b>						
“ON” Resistance	$R_{ON}$	$R_L=10k\Omega\sim(V_{DD}-V_{SS}/2)$ , $V_{CON}=V_{DD}, V_{SS}\sim V_{DD}$	$V_{DD}=5V$	240	1050	$\Omega$
			$V_{DD}=10V$	120	400	
			$V_{DD}=15V$	80	240	
$\Delta$ “ON” Resistance Between Any 2 of 4 Switches	$\Delta R_{ON}$	$R_L=10k\Omega\sim(V_{DD}-V_{SS}/2)$ , $V_{CC}=V_{DD}, V_{IS}=V_{SS}\sim V_{DD}$	$V_{DD}=10V$	10		$\Omega$
			$V_{DD}=15V$	5		
Input or Output Leakage Switch “OFF”	$I_{IS}$	$V_{CON}=0$		$\pm 0.1$	$\pm 50$	nA
<b>CONTROL INPUTS</b>						
LOW Level Input Voltage	$V_{ILC}$	$V_{IS}=V_{SS}$ and $V_{DD}$ , $V_{OS}=V_{DD}$ and $V_{SS}$ , $I_{IS}=\pm 10\mu A$	$V_{DD}=5V$	2.25	1.5	V
			$V_{DD}=10V$	4.5	3.0	
			$V_{DD}=15V$	6.75	4.0	
HIGH Level Input Voltage	$V_{IHC}$		$V_{DD}=5V$	3.5	2.75	V
			$V_{DD}=10V$ (Note 5)	7.0	5.5	
			$V_{DD}=15V$	11.0	8.25	
Input Current	$I_{IN}$	$V_{DD}-V_{SS}=15V, V_{DD}\geq V_{IS}\geq V_{SS}$ , $V_{DD}\geq V_{CON}\geq V_{SS}$		$\pm 10^{-5}$	$\pm 0.3$	$\mu A$

## ■ AC ELECTRICAL CHARACTERISTICS

( $T_A=25^{\circ}\text{C}$ ,  $t_R=t_F=20\text{nS}$  and  $V_{SS}=0\text{V}$ , unless otherwise specified) (Note 1)

PARAMETER	SYMBOL	TEST CONDITIONS	MIN	TYP	MAX	UNIT	
Propagation Delay Time Signal	$t_{PHL}, t_{PLH}$	$V_{CON}=V_{DD}, C_L=5\text{pF}, R_L=200\text{k}\Omega$ (Fig. 1)	$V_{DD}=5\text{V}$		25	55	ns
			$V_{DD}=10\text{V}$		15	35	ns
			$V_{DD}=15\text{V}$		10	25	ns
Propagation Delay Time Control Input to Signal Output High Impedance to Logical Level	$t_{PZH}, t_{PZL}$	$R_L=1\text{k}\Omega, C_L=50\text{pF}$ , (Fig. 2, 3)	$V_{DD}=5\text{V}$			125	ns
			$V_{DD}=10\text{V}$			60	ns
			$V_{DD}=15\text{V}$			50	ns
Propagation Delay Time Control Input to Signal Output Logical Level to High Impedance	$t_{PHZ}, t_{PLZ}$	$R_L=1\text{k}\Omega, C_L=50\text{pF}$ , (Fig. 2, 3)	$V_{DD}=5\text{V}$			125	ns
			$V_{DD}=10\text{V}$			60	ns
			$V_{DD}=15\text{V}$			50	ns
Sine Wave Distortion		$V_{CON}=V_{DD}=5\text{V}, V_{SS}=-5\text{V}, R_L=10\text{k}\Omega, V_{IS}=5\text{V}_{p-p}, f=1\text{kHz}$ (Fig. 4)		0.1		%	
Frequency Response-Switch "ON" (Frequency at -3dB)		$V_{CON}=V_{DD}=5\text{V}, V_{SS}=-5\text{V}, R_L=1\text{k}\Omega, 20 \text{Log}_{10}(V_{OS}/V_{IS})=-3\text{dB}, V_{IS}=5.0\text{V}_{p-p}$ (Fig. 4)		40		MHz	
Feedthrough - Switch "OFF" (Frequency at -50dB)		$V_{DD}=5.0\text{V}, V_{CC}=V_{SS}=-5.0\text{V}, R_L=1\text{k}\Omega, V_{IS}=5.0\text{V}_{p-p}, 20 \text{Log}_{10}(V_{OS}/V_{IS})=-50\text{dB}$ (Fig. 4)		1.25		MHz	
Crosstalk Between Any Two Switches (Frequency at -50dB)		$V_{DD}=V_{CON(A)}=5.0\text{V}, R_L=1\text{k}\Omega, V_{SS}=V_{CON(B)}=5.0\text{V}, V_{IS(A)}=5.0\text{V}_{p-p}, 20 \text{Log}_{10}(V_{OS(B)}/V_{IS(A)})=-50\text{dB}$ (Fig. 5)		0.9		MHz	
Crosstalk, Control Input to Signal Output		$V_{DD}=10\text{V}, R_L=10\text{k}\Omega, R_{IN}=1\text{k}\Omega, V_{CC}=10\text{V}$ Square Wave, $C_L=50\text{pF}$ (Fig. 6)		150		mV <sub>P-P</sub>	
Maximum Control Input		$R_L=1\text{k}\Omega, C_L=50\text{pF}, V_{OS(f)}=\frac{1}{2} V_{OS}(1\text{kHz})$ (Fig. 7)	$V_{DD}=5\text{V}$		6		MHz
			$V_{DD}=10\text{V}$		8		MHz
			$V_{DD}=15\text{V}$		8.5		MHz
Signal Input Capacitance	$C_{IS}$			8.0		pF	
Signal Output Capacitance	$C_{OS}$	$V_{DD}=10\text{V}$		8.0		pF	
Feedthrough Capacitance	$C_{IOS}$	$V_{CON}=0\text{V}$		0.5		pF	
Control Input Capacitance	$C_{IN}$			5.0	7.5	pF	

Notes: 1. AC Parameters are guaranteed by DC correlated testing.

2. These devices should not be connected to circuits with the power "ON".

3. In all cases, there is approximately 5 pF of probe and jig capacitance in the output; however, this capacitance is included in  $C_L$  wherever it is specified.

4.  $V_{IS}$  is the voltage at the in/out pin and  $V_{OS}$  is the voltage at the out/in pin.  $V_{CON}$  is the voltage at the control input.

5. Conditions for  $V_{IHC}$ :

- $V_{IS}=V_{DD}, I_{OS}=\text{standard B series } I_{OH}$
- $V_{IS}=0\text{V}, I_{OL}=\text{standard B series } I_{OL}$

■ SPECIAL CONSIDERATION

Using continuously under heavy loads may cause UTC **UCD4066** to decrease in the reliability even if the operating conditions are within the absolute maximum ratings and the operating ranges.

In applications where separate power sources are used to drive  $V_{DD}$  and the signal input, the  $V_{DD}$  current capability should exceed  $V_{DD}/R_L$ . This provision avoids any permanent current flow or clamp action of the  $V_{DD}$  supply when power is applied or removed from UTC **UCD4066**.

■ AC TEST CIRCUIT AND SWITCHING TIME WAVEFORMS

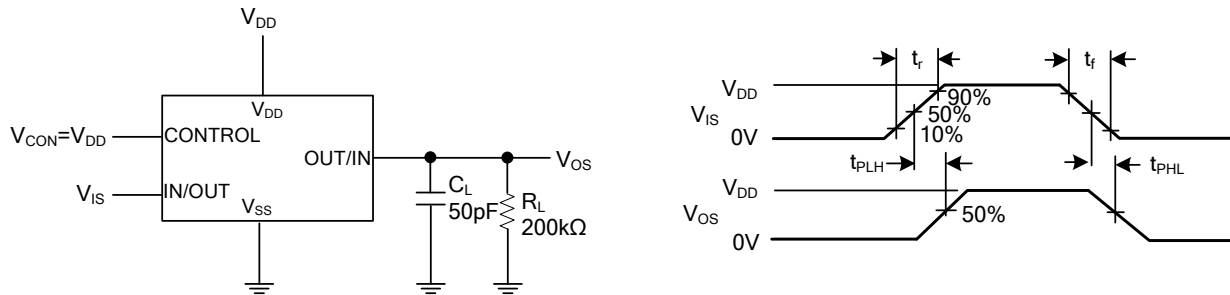

Fig. 1  $t_{PHL}$ ,  $t_{PLH}$  Propagation Delay Time Signal Input to Signal Output

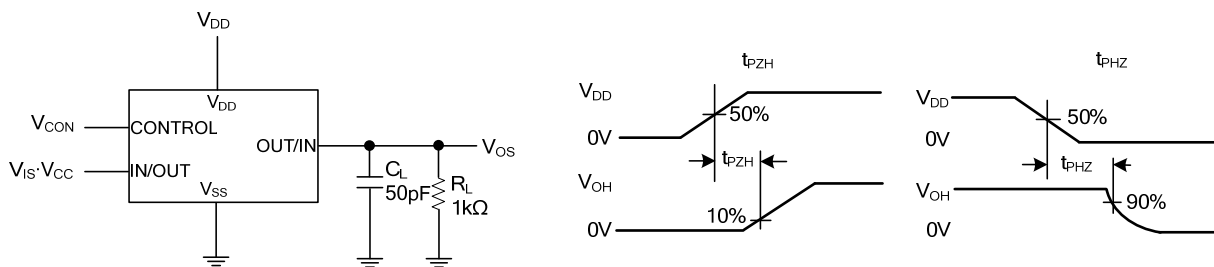

Fig. 2  $t_{PZH}$ ,  $t_{PHZ}$  Propagation Delay Time Control to Signal Output

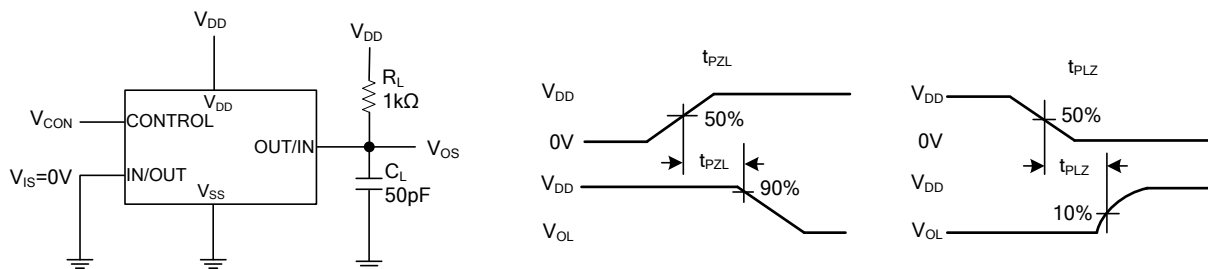
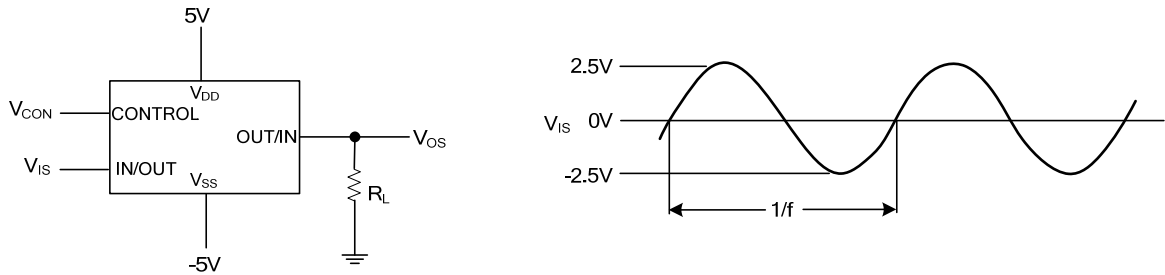

Fig. 3  $t_{PZL}$ ,  $t_{PLZ}$  Propagation Delay Time Control to Signal Output

■ AC TEST CIRCUIT AND SWITCHING TIME WAVEFORMS(Cont.)



$V_{CON}=V_{DD}$  for distortion and frequency response tests  
 $V_{CON}=V_{SS}$  for feedthrough test

Fig. 4 Sine Wave Distortion, Frequency Response and Feedthrough

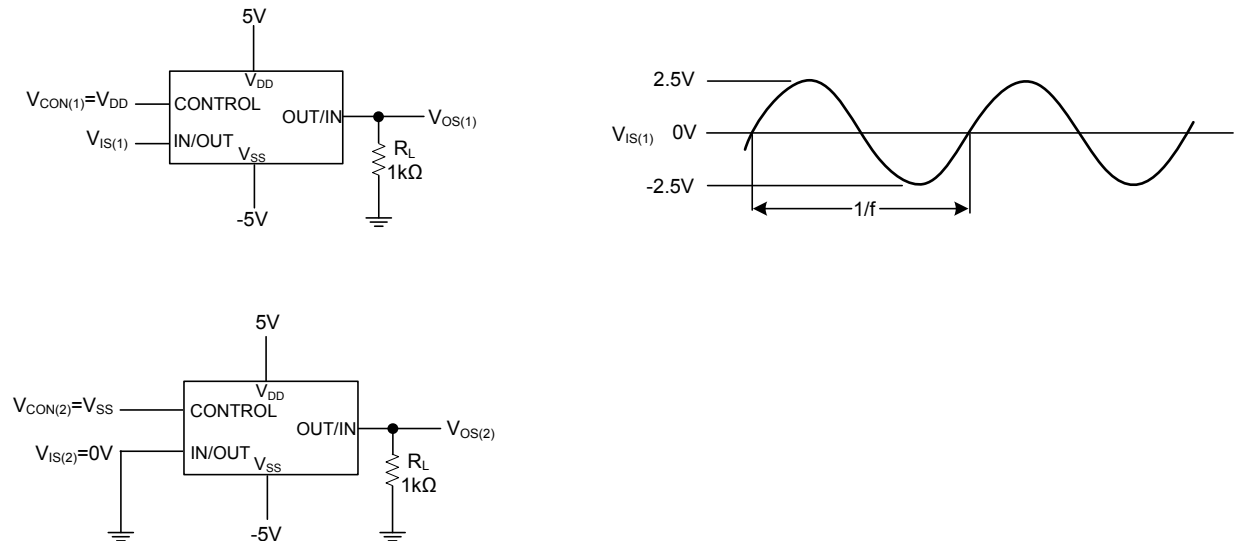

Fig. 5 Crosstalk Between Any Two Switches

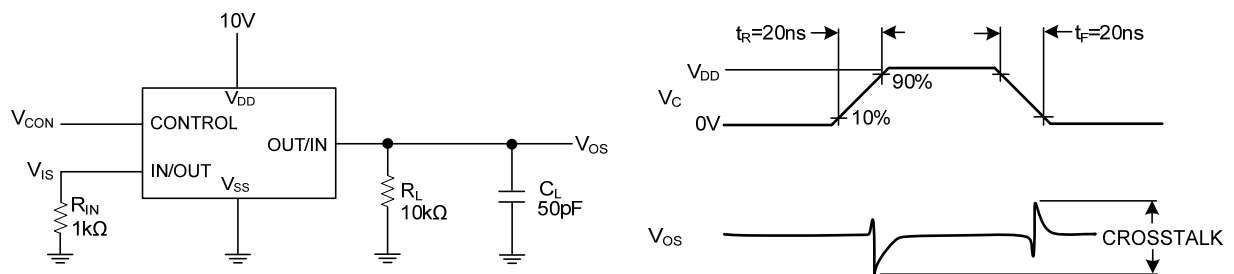

Fig. 6 Crosstalk: Control Input to Signal Output

■ AC TEST CIRCUIT AND SWITCHING TIME WAVEFORMS(Cont.)

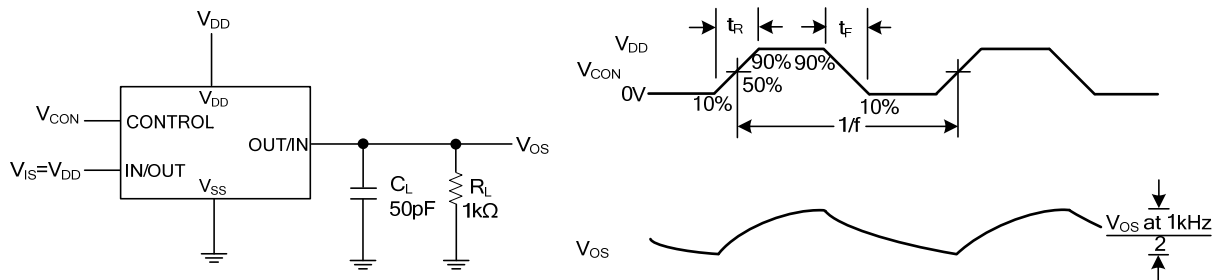

Fig. 7 Maximum Control Input Frequency

UTC assumes no responsibility for equipment failures that result from using products at values that exceed, even momentarily, rated values (such as maximum ratings, operating condition ranges, or other parameters) listed in products specifications of any and all UTC products described or contained herein. UTC products are not designed for use in life support appliances, devices or systems where malfunction of these products can be reasonably expected to result in personal injury. Reproduction in whole or in part is prohibited without the prior written consent of the copyright owner. The information presented in this document does not form part of any quotation or contract, is believed to be accurate and reliable and may be changed without notice.