



L5107

Preliminary

LINEAR INTEGRATED CIRCUIT

CONSTANT CURRENT BOOST CONTROLLER FOR DRIVING HIGH POWER LEDs

DESCRIPTION

The UTC **L5107** is a high powered PWM boost converter optimized for constant current applications such as driving one or more strings of high power LEDs. The powerful drive circuitry can deliver up to 70W to the LED system.

The output current can be set by an external resistor connected the IADJ pin and GND. This average current can be reduced by applying a PWM signal to the PWMD pin. The UTC **L5107** offers a dither feature to reduce EMI.

The UTC **L5107** has a large input voltage range from 6V to 45V and the switching frequency can be set by an external resistor between 100kHz and 1MHz for different LED systems. To protect the device over voltage protection circuit and under voltage lock-out circuit have been incorporated as well as thermal shutdown circuit.

The UTC **L5107** is available in the HTSSOP 16-pin TSSOP package.

FEATURES

- * Input voltage range: 6V~45V
- * Feedback voltage: 0.25V±3%
- * Maximum out power of 70W
- * Programmable switching frequency and LED drive current
- * Ultra low EMI via dithering on the UTC L5107
- * Single pin for PWM dimming
- * Protection circuit:
 - Over voltage protection circuit
 - Over temperature protection circuit
 - Under-voltage Lock-out circuit
- * Accurate over the -40~125°C temperature range

ORDERING INFORMATION

Ordering Number		Package	Packing
Lead Free	Halogen Free		
L5107L-P16-T	L5107G-P16-T	TSSOP-16	Tube
L5107L-P16-R	L5107G-P16-R	TSSOP-16	Tape Reel

Note: xx: Output Voltage, refer to Marking Information.

<p>L5107L-P16-R</p>	<p>(1) T: Tube, R: Tape Reel</p> <p>(2) P16: TSSOP-16</p> <p>(3) L: Lead Free, G: Halogen Free</p>
---------------------	--

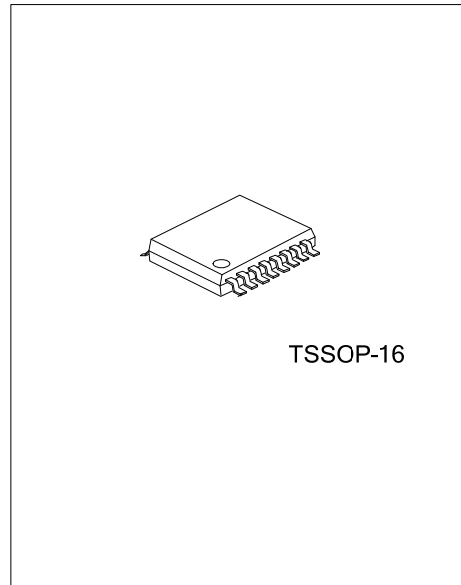

TSSOP-16

■ PIN CONFIGURATION

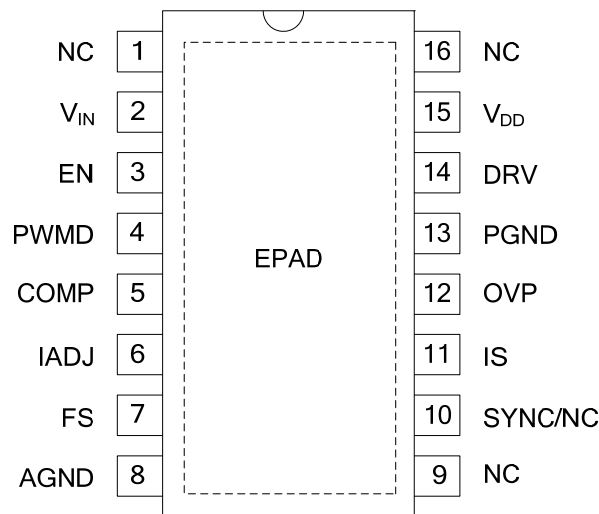

■ PIN DESCRIPTION

PIN NO.	PIN NAME	DESCRIPTION
1	NC	No Connection.
2	V _{IN}	Power Input Pin. The external voltage supply is connected to this pin. A 4.7μF/50V capacitor must be connected across this pin and GND.
3	EN	Enable Control Pin. Pull high to turn on. A 100kΩ resistor can be connected across this pin and VIN.
4	PWMD	Dimming PWM Control Pin. Logic High terminates the output power. Logic Low starts up the output power.
5	COMP	Error Amp Output Pin. A 10nF capacitor must be connected across this pin and GND for external compensation.
6	IADJ	Output Feedback Pin. The reference is 0.25V.
7	FS	Timing Resistance Connection Pin. Connected to a Resistor to determine the operating frequency.
8	AGND	Analog Ground.
9	NC	No Connection.
10	SYNC	Frequency Synchronize Pin. The UTC L5107 can be Connected together by this pin to synchronize multiple converters.
11	IS	Current Sense Pin. Connected to external current sense resistor which in turn is connected to the source of the external FET as well as an external slope compensation resistor.
12	OVP	OVP Divider Connect Pin. Connect the top of the divider string to the output. If the load is disconnected, the output voltage will rise until OVP reaches 1.25V and then will regulate around this point.
13	PGND	Power Ground.
14	DRV	Drive Output. Connect to the gate of external FET.
15	V _{DD}	VDD Filter Connect Pin. Connect a 10μF/10V capacitor to GND. It is also the positive supply for the Driver. Do not connect an external load to this pin.
16	NC	No Connect.
	EPAD	Connect to AGND.

■ BLOCK DIAGRAM

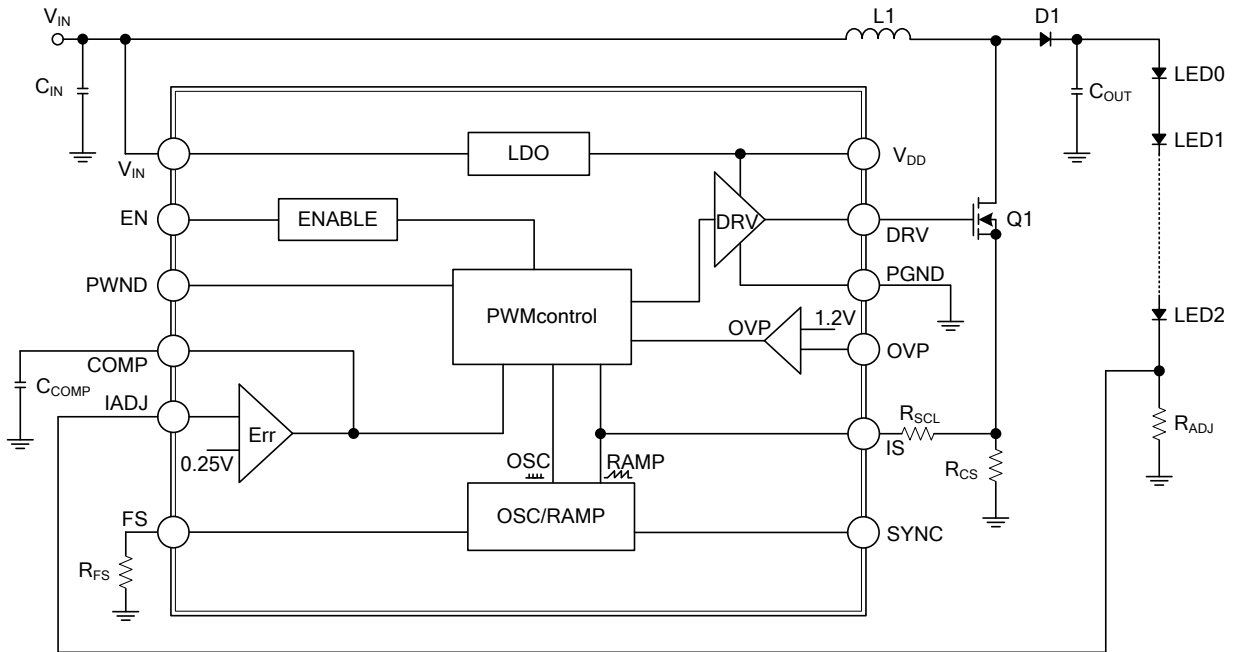

Figure 1. Functional Block Diagram

■ ABSOLUTE MAXIMUM RATING(Note 1)

PARAMETER	SYMBOL	RATINGS	UNIT
Supply Voltage	V_{IN}	+48	V
Enable Pin Voltage	V_{EN}	-0.3~+6	V
IADJ Voltage	V_{ADJ}	+6	V
Storage Temperature	T_S	-65~+150	°C

Note: Absolute maximum ratings are those values beyond which the device could be permanently damaged. Absolute maximum ratings are stress ratings only and functional device operation is not implied.

■ THERMAL DATA(Note 3)

PARAMETER	PACKAGE	SYMBOL	RATINGS	UNIT
Junction Thermal Resistance		θ_{JA}	36.5	°C/W

■ OPERATING RATINGS(Note 3)

PARAMETER	SYMBOL	RATINGS	UNIT
Supply Voltage	V_{IN}	+6~+45	V
Junction Temperature	T_J	-40~+125	°C

■ ELECTRICAL CHARACTERISTICS(Note 4)

($V_{IN}=12V$, $V_{EN}=3.6V$, $L=47\mu H$, $C=4.7\mu F$, $T_J=25^\circ C$, Bold values indicate $-40^\circ C \leq T_J \leq +125^\circ C$, unless noted)

PARAMETER	SYMBOL	TEST CONDITIONS	MIN	TYP	MAX	UNIT
Supply Voltage Range	V_{IN}		6		45	V
Under Voltage Lockout	UVLO		3.5	4.9	5.5	V
Quiescent Current	I_{VIN}	$V_{FB}>275mV$ (to ensure device is not switching)		3.2	10	mA
Shutdown Current	I_{SD}	$V_{EN}=0V$		30		μA
Feedback Voltage (at IADJ)	V_{IADJ}	Room temperature (3%)	242.5	250	257.5	mV
		$-40^\circ C \leq T_J \leq +125^\circ C$ (5%)	237.5	250	262.5	mV
Feedback Input Current	I_{ADJ}	$V_{FB}=250mV$		1.2	3	μA
Line Regulation	S_V	$V_{IN}=12V \sim 24V$		2		%
Load Regulation	S_I	V_{OUT} to $2 \times V_{OUT}$		2		%
Maximum Duty Cycle	D_{MAX}		88			%
Enable Threshold	V_{EN}	Turn ON		1.15	1.5	V
		Turn OFF	0.4	1.1		
Enable Pin Current	I_{EN}	$V_{EN}=3.3V$, $R_{EN}=100k\Omega$		17	30	μA
PWMD Threshold	V_{PWM}	Turn ON		0.75	1.5	V
		Turn OFF	0.4	0.7		
PWMD Frequency Range	f_{PWMD}	$L=47\mu H$, $C=4.7\mu F$ (Note 5)	0		500	Hz
Programmable Oscillator Frequency	f_{SW}	$R_{REQ}=82.5k\Omega$		109		kHz
		$R_{REQ}=21k\Omega$	360	400	440	
		$R_{REQ}=8.25k\Omega$		950		
Low EMI	F_{DITHER}	Frequency dither shift from nominal		± 12		%
Current Limit Threshold Voltage	V_{SENS}	$R_{SENSE}=390\Omega$	0.315	0.45	0.585	V
I_{SENSE} Peak Current Out	I_{SENSE}	$R_{SENSE}=390\Omega$		250		μA
Over Voltage Protection	V_{OVP}		1.203	1.24	1.277	V
Driver Impedance	R_{ON}	Sink		2.4	3.5	Ω
		Source		2		
Driver Voltage High	V_{DRH}	$V_{IN}=12V$	7	9	11	V
Over-Temperature Threshold Shutdown	T_J			150		$^\circ C$
Thermal Shutdown	T_H	Hysteresis		5		$^\circ C$

Notes: 1. Exceeding the absolute maximum rating may damage the device.

2. Devices are ESD sensitive. Handling precautions recommended. Human body model, 1.5k Ω in series with 100pF.

3. The device is not guaranteed to function outside its operating rating.

4. Specification for packaged product only.

5. Guaranteed by design

■ FUNCTIONAL DESCRIPTION

The UTC **L5107** DC-DC converter is based on a peak current mode PWM architecture which regulates the feedback voltage at 0.25V under normal operating conditions. The constant output current converter is the preferred method for driving LEDs. Figure 2 shows the typical application schematic.

The UTC **L5107** configured as a boost controller can allow for the design of multiple LEDs in series to help maintain color and brightness.

The input voltage range of the UTC **L5107** is very wide, from 6V to 45V. In addition, the LED current and the switching frequency can be programmed to a wide range of values through the external resistors for different LED systems. The UTC **L5107** can also control the brightness of the LEDs through its PWMD pin.

■ POWER TOPOLOGY

Constant Output Current Controller

The UTC **L5107** as a peak current mode boost controller has been designed to provide a constant output current. In the boost configuration, the output can be set from V_{IN} up to 100V.

This LED driver features a built-in soft-start circuitry in order to prevent start-up surges. Other protection features include:

- * Current Limit (I_{LIMIT})-Current sensing for over current and overload protection
- * Over Voltage Protection (OVP)-Output over voltage protection to prevent operation above a safe upper limit
- * Under Voltage Lockout (UVLO)-UVLO designed to prevent operation at very low input voltages

Setting the LED Current

The current through the LED string is set by the resistor, R_{ADJ} . This value can be calculated using Equation 1:

$$\text{Eq. (1)} \quad I_{LED} = \frac{0.25V}{R_{ADJ}}$$

V_{DD}

V_{DD} is an internal linear regulator power supply for the internal circuitry of the UTC **L5107**. A 10 μ F ceramic bypass capacitor is required at the V_{DD} pin. This pin is for filtering only and should not connect an external load to this pin.

Soft Start

A soft start build in the boost switching converter is used to limit the inrush current from the line supply. The soft start delay can be set using the compensation capacitor (C_{COMP} in Figure 2).

A 10nF ceramic capacitor will be OK at all operating conditions.

Oscillator and Switching Frequency Selection

In the UTC **L5107**, the switching frequency can be set by choosing the appropriate value for the resistor, R_{FS} according to Equation 2:

$$\text{Eq. (2)} \quad R_{FS}(K\Omega) = \left(\frac{7530}{F_{SW}(kHz)} \right)^{1.035}$$

Dithering

The UTC **L5107** has a feature which dithers the switching frequency by $\pm 10\%$. The purpose of this dithering is to help achieve a spread spectrum of the conducted EMI noise. This can allow for an overall reduction in noise emission by approximately 10dB.

LED Dimming

The UTC **L5107** of LED drivers can dim the brightness of the LED string. A PWM input signal of up to 500Hz can be applied to the PWMD pin (see Figure 2) to pulse the LED string ON and OFF. It is recommended to use PWM dimming signals above 120Hz to avoid any recognizable flicker by the human eye. PWM dimming is the preferred way to dim a LED in order to prevent color/wavelength shifting, as occurs with analog dimming. The output current level remains constant during each PWMD pulse.

■ POWER TOPOLOGY(Cont.)**Output Over Voltage Protection (OVP)**

The UTC **L5107** provides an OVP circuitry with a reference value of 1.25V in order to protect the system from an over voltage fault condition. This OVP point can be programmed through the use of external resistors (R1 and R2 in Figure 2). This OVP voltage can be calculated using Equation 3:

$$\text{Eq. (3)} \quad V_{\text{OVP}} = \frac{1.25 \times (R_1 + R_2)}{R_2}$$

Current Limit

The UTC **L5107** features a current limit protection feature to prevent any current runaway conditions. The current limit circuitry monitors current on a pulse by pulse basis. It limits the current through the inductor by sensing the voltage across R_{CS} . When 0.45V is present at the IS pin, the pulse is truncated. The next pulse continues as normally until the IS pin reaches 0.45V and it is truncated once again. This will continue until the output load is decreased.

Select R_{CS} using Equation 4:

$$\text{Eq. (4)} \quad R_{\text{CS}} = \frac{0.45}{\frac{(V_{\text{OUTMAX}} - V_{\text{INMIN}}) \times D}{L \times F_{\text{SW}}} + I_{\text{LPK_LIMIT}}}$$

Slope Compensation

The UTC **L5107** requires slope compensation for the peak current mode controller. The UTC **L5107** uses an external resistor, R_{SLC} for slope compensation. The ability to set the proper slope compensation through the use of a single external component results in design flexibility. Select R_{SLC} using Equation 5:

$$\text{Eq. (5)} \quad R_{\text{SLC}} = \frac{(V_{\text{OUTMAX}} - V_{\text{INMIN}}) \times R_{\text{CS}}}{L \times 250\mu\text{A} \times F_{\text{SW}}}$$

■ TYPICAL APPLICATION CIRCUIT

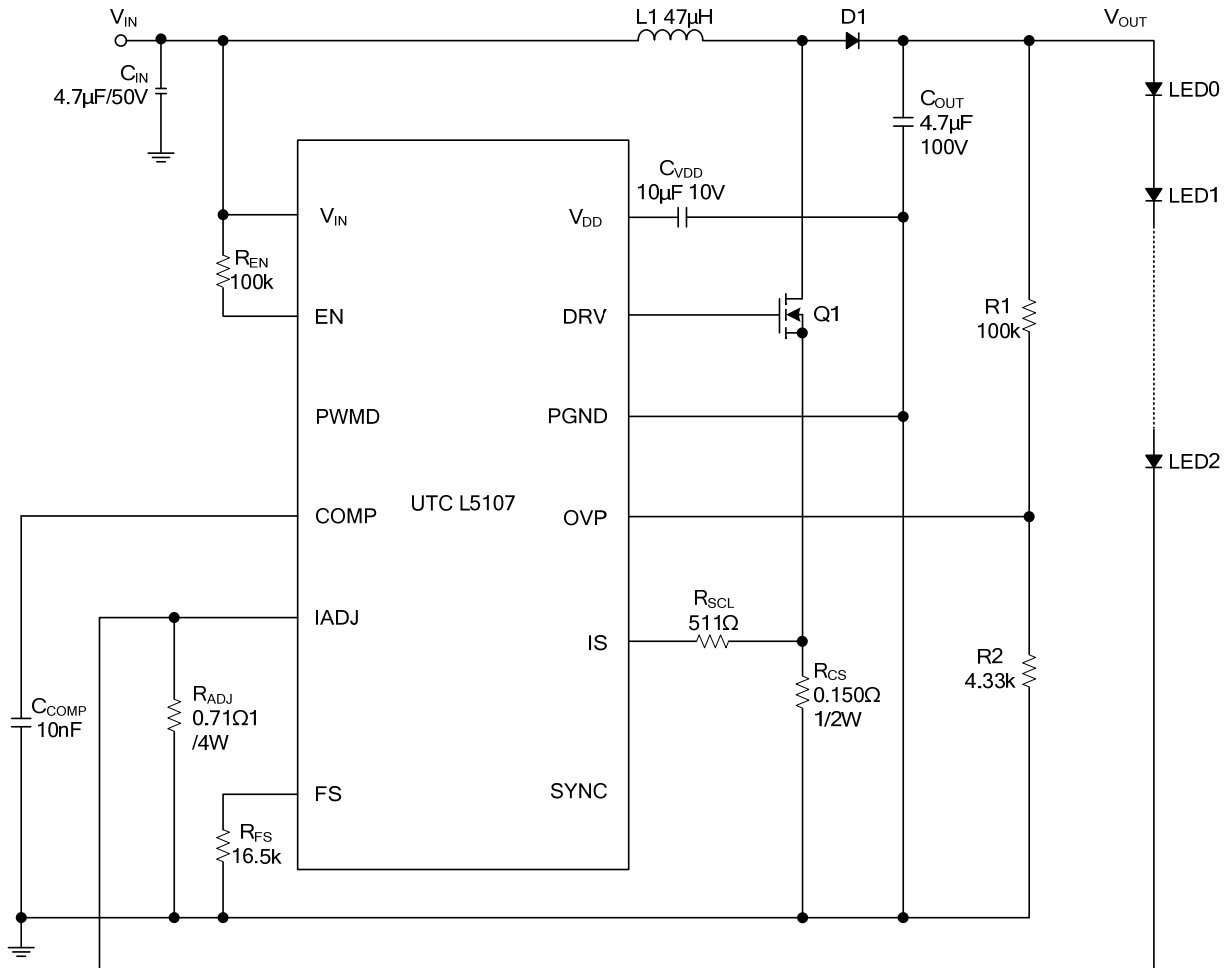

Figure 2. Typical Application of the UTC L5107 LED Driver

UTC assumes no responsibility for equipment failures that result from using products at values that exceed, even momentarily, rated values (such as maximum ratings, operating condition ranges, or other parameters) listed in products specifications of any and all UTC products described or contained herein. UTC products are not designed for use in life support appliances, devices or systems where malfunction of these products can be reasonably expected to result in personal injury. Reproduction in whole or in part is prohibited without the prior written consent of the copyright owner. The information presented in this document does not form part of any quotation or contract, is believed to be accurate and reliable and may be changed without notice.