



UPSS1650

Preliminary

CMOS IC

HIGH PRECISION CC/CV PRIMARY-SIDE PWM POWER SWITCH

DESCRIPTION

The UTC **UPSS1650** is a primary control switch mode charger and adapter applications. The controlled variable is transferred by an auxiliary winding from the secondary to the primary side. The device integrates PWM controller to enhance the performance of discontinuous conduction mode (DCM) flyback converters.

The UTC **UPSS1650** operates in primary-side sensing and regulation. Opto-coupler and TL431 could be eliminated. It also provides off-time modulation to linearly decrease PWM frequency under light-load conditions so that low standby power can be achieved.

The UTC **UPSS1650** achieves high precision CV/CC regulation and high power efficiency. It offers comprehensive protection coverage with auto-recovery features including Cycle-by-cycle current limiting, V_{DD} over voltage protection, V_{DD} clamp, OTP, leading edge blanking, V_{DD} under voltage lockout, etc.

FEATURES

- * Built-in 600V Power MOSFET
- * $\pm 5\%$ constant voltage regulation at universal AC input
- * High precision constant current regulation at universal AC input
- * Primary side control without TL431 and opto-coupler
- * Programmable CV and CC regulation
- * Programmable cable compensation in CV mode
- * Flyback topology in DCM operation
- * Frequency hopping to reduce system EMI
- * Built-in leading edge blanking
- * Built-in primary winding inductance compensation
- * Power on soft start
- * Gate Output Maximum Voltage Clamped at 15V
- * Cycle-by-cycle current limiting
- * Over voltage protection
- * V_{DD} under-voltage lockout

ORDERING INFORMATION

Ordering Number		Package	Packing
Lead Free	Halogen Free		
UPSS1650L-D08-T	UPSS1650G-D08-T	DIP-8	Tube
UPSS1650L-S08-R	UPSS1650G-S08-R	SOP-8	Tape Reel

<p>UPSS1650L-D08-T</p> <p>(1) Packing Type (2) Package Type (3) Halogen Free</p>	<p>(1) T: Tube, R: Tape Reel (2) D08: DIP-8, S08: SOP-8 (3) L: Lead Free, G: Halogen Free</p>
------------------------------------------------------------------------------------------	-------------------------------------------------------------------------------------------------------

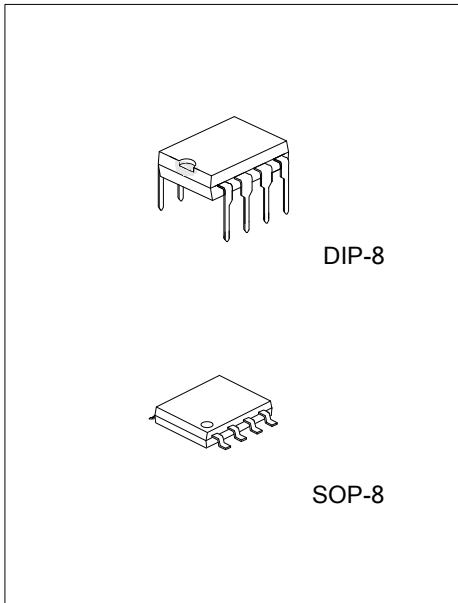

PIN CONFIGURATION

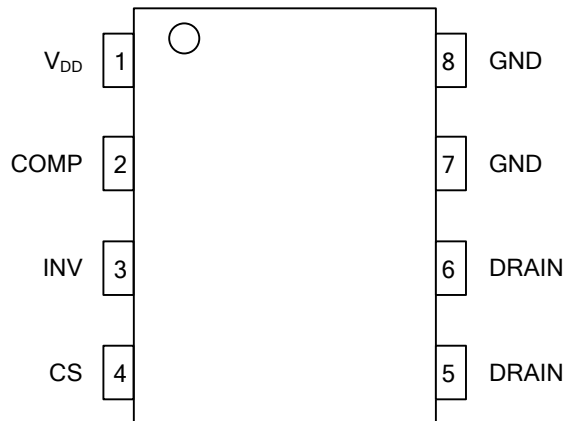

PIN DESCRIPTION

PIN NO.	PIN NAME	DESCRIPTION
1	V _{DD}	Power Supply
2	COMP	Loop Compensation
3	INV	The voltage feedback from the auxiliary winding
4	CS	Current sense input
5/6	DRAIN	Power MOSFET Drain Pin
7/8	GND	Ground

BLOCK DIAGRAM

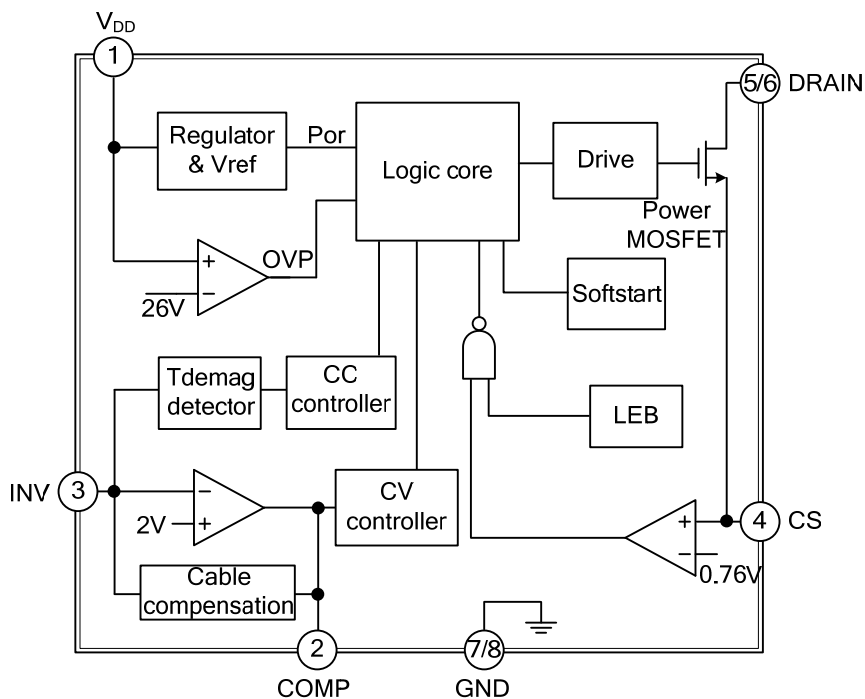

■ ABSOLUTE MAXIMUM RATING

PARAMETER	SYMBOL	RATINGS	UNIT
Drain Voltage (Off State)	B_{VDSS}	-0.3~ B_{vdss}	V
V_{DD} Zener Clamp Continuous Current	I_{DD}	10	mA
COMP Voltage	V_{COMP}	-0.3~7	V
CS Input Voltage	V_{CS}	-0.3~7	V
INV Input Voltage	V_{INV}	-0.3~7	V
Operating Junction Temperature	T_J	-20~150	°C
Storage Temperature	T_{STG}	-55~150	°C

Notes: 1. Absolute maximum ratings are those values beyond which the device could be permanently damaged.

Absolute maximum ratings are stress ratings only and functional device operation is not implied.

2. Drain Pin Connected 100mm² PCB copper clad.

■ THERMAL CHARACTERISTICS

PARAMETER	SYMBOL	RATINGS	UNIT
Junction to Ambient	θ_{JA}	75	°C/W
		90	°C/W

■ OUTPUT POWER TABLE

PARAMETER	RATINGS	UNIT
Adapter (Note)	230VAC±15%	6
	85-264VAC	5

Note: Maximum practical continuous power in an Adapter design with sufficient drain pattern as a heat sink, at 50°C ambient.

■ **ELECTRICAL CHARACTERISTICS** ($T_A=25^{\circ}\text{C}$, $V_{DD}=15\text{V}$, unless otherwise specified)

PARAMETER	SYMBOL	TEST CONDITIONS	MIN	TYP	MAX	UNIT
SUPPLY SECTION						
Turn-on Threshold Voltage	$V_{TH(ON)}$		13.5	14.5	15.5	V
Turn-off Threshold Voltage	$V_{TH(OFF)}$		8.5	9	9.5	V
V_{DD} OVP Protection	V_{DD_OVP}			26		V
Startup Current	I_{DD-ST}			5	20	μA
Operating Current	I_{DD-OP}			1.6	2	mA
Green-Mode Operating Current	$I_{DD-GREEN}$			1.3		mA
OSCILLATOR SECTION						
Maximum Frequency	f_{OSC}		50	55	60	kHz
Minimum Frequency at CCM	$f_{OSC-CM-MIN}$			18		kHz
Minimum Frequency at No-load	$f_{OSC-N-MIN}$			370		Hz
Frequency Hopping Range	$\Delta f/freq$			± 5.0		%
Frequency Hopping Period	t_{FHR}			3		ms
Frequency Variation vs. V_{DD} Deviation	f_{DV}	$V_{DD}=10\sim 25\text{V}$		1	2	%
Frequency Variation vs. Temperature Deviation	f_{DT}	$T_A=-20^{\circ}\text{C}\sim +150^{\circ}\text{C}$			15	%
INV SECTION						
Reference Voltage for EA	V_{VR}		1.94	2.00	2.03	V
Reference Voltage for CCM	V_{VR_CCM}			0.5		V
Max. Cable Compensation Current	I_{CABLE_MAX}			42		μA
CURRENT SENSE SECTION						
Current Sense Threshold Voltage	V_{CS}		740	760	780	mV
OCP Propagation Delay	t_{D_OC}			90	200	nS
Leading Edge Blank Time	t_{LEB}			540		nS
Soft Start Time	t_{SS}			10		mS
POWER MOSFET SECTION						
MOSFET DS Breakdown Voltage	B_{VDSS}		600			V
On Resistance	$R_{DS(ON)}$		17		20	Ω
OTP SECTION						
Threshold Temperature of OTP (Note)	T_{OTP}			+140		$^{\circ}\text{C}$

Note: When the over-temperature protection is activated, the power system enters auto restart mode and output is disabled.

■ OPERATION DESCRIPTION

The UTC **UPSS1650** is a primary control switch mode charger and adapter applications. It operates in primary-side sensing and regulation. Opto-coupler and TL431 could be eliminated. Proprietary built-in CV and CC control can achieve high precision CV/CC performance. The device integrates PWM controller to enhance the performance of discontinuous conduction mode (DCM) flyback converters.

Startup control

The V_{DD} pin of UTC **UPSS1650** is connected to the line input through a resistor. A large value startup resistor can be used to minimize the power loss in application because the start current of UTC **UPSS1650** is very low. When the V_{DD} voltage reaches $V_{TH(ON)}$, the internal startup circuit is disabled and the IC turns on.

Operating Current

The Operating current of UTC **UPSS1650** is as low as 1.6mA. Good efficiency and very low standby power can be achieved.

Constant Voltage Operation

The output voltage is defined by the transmission ratio between the secondary and auxiliary winding. The UTC **UPSS1650** captures the auxiliary winding feedback voltage at INV pin and operates in constant-voltage (CV) mode to regulate the output voltage. The auxiliary voltage reflects the output voltage is given by:

$$V_{AUX} = \frac{N_A}{N_S} \times (V_O + \Delta V) \tag{1}$$

Where ΔV indicates the drop voltage of the output diode.

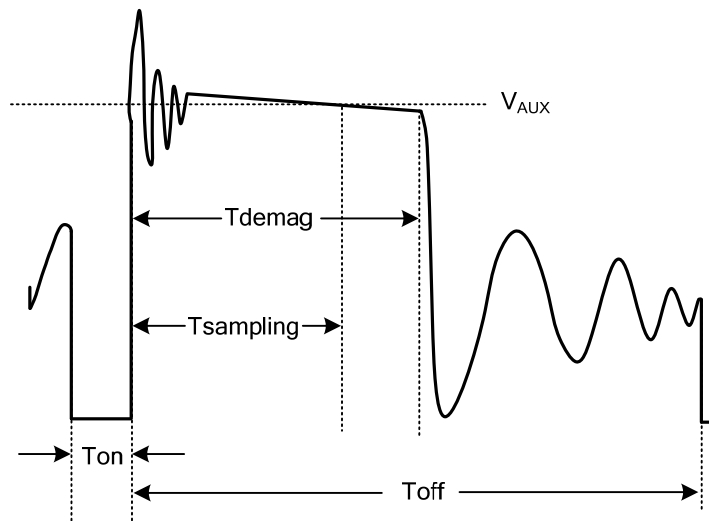

Figure 2. Auxiliary voltage waveform

Via a resistor divider connected between the auxiliary winding and INV, the V_{AUX} is sampled at the $T_{sampling}$ end and it is hold until the next sampling. The sampled voltage is compared with 2.0V reference voltage and the error is amplified. The error amplifier output reflects the load condition and controls the T_{OFF} time and the I_{pk} to regulate the output voltage, thus constant output voltage can be achieved.

Constant Current Operation

When the sampled voltage is below 2.0V reference voltage and the error amplifier output reaches its maximum, thus UTC **UPSS1650** operates in constant-current (CC) mode. The CC point and maximum output power can be externally adjusted by external current sense resistor R_{cs} . The larger R_{cs} , the smaller CC point is, and the smaller output power becomes.

■ OPERATION DESCRIPTION(Cont.)

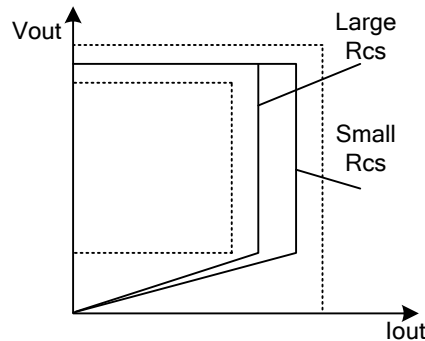

Figure 3. Adjustable output power by changing Rcs

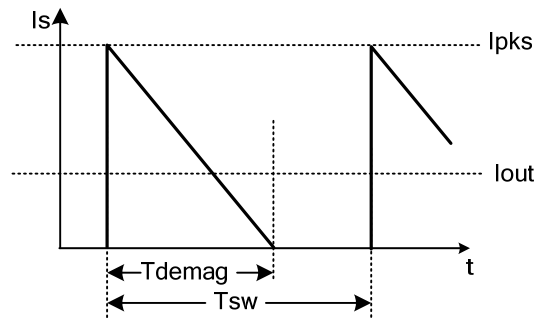

Figure 4. Secondary current waveform

In CC operation, the CC loop control function of UTC **UPSS1650** will keep a fixed proportion between secondary inductance de-magnetization time (T_{demag}) and switching cycle time (T_{sw}). The fixed proportion is

$$\frac{T_{demag}}{T_{sw}} = \frac{1}{2} \tag{2}$$

Thus the output current is given by:

$$I_{out} = \frac{1}{2} \times \frac{N_p}{N_s} \times I_{pk} \times \frac{T_{demag}}{T_{sw}} = \frac{1}{4} \times \frac{N_p}{N_s} \times I_{pk} \tag{3}$$

Programmable Cable Drop Compensation

UTC **UPSS1650** has a built-in cable voltage drop compensation to achieve good load regulation. An offset voltage is generated at INV pin by an internal current flowing into the resistor divider. The current is inversely proportional to the voltage of COMP pin. As a result, it is inversely proportional to the output load current. The voltage drop across the cable is compensated by this offset voltage at INV pin. It can also be programmed by adjusting the resistance of the divider to compensate the drop for various cable lines used.

Current Sensing and Leading Edge Blanking

Cycle-by-cycle current limiting is offered in UTC **UPSS1650**. The switch current is detected by a sense resistor into the CS pin. When the power switch is turned on, a turn-on spike will occur on this resistor. A 500ns leading-edge blanking is built in to avoid false-termination of the switching pulse so that the external RC filtering is no longer needed.

■ OPERATION DESCRIPTION(Cont.)

Protection Control

Good power supply system reliability is achieved with its comprehensive protection features including V_{DD} over-voltage protection, V_{DD} Clamp, GATE Clamp, Power on soft start, Cycle-by-cycle current limiting, short circuit protection, leading edge blanking, OTP and UVLO, etc.

V_{DD} is supplied by transformer auxiliary winding output. The output of UTC **UPSS1650** is shutdown when V_{DD} drops below $V_{TH(OFF)}$ and the power converter enters power on start-up sequence thereafter.

■ TYPICAL APPLICATION CIRCUIT

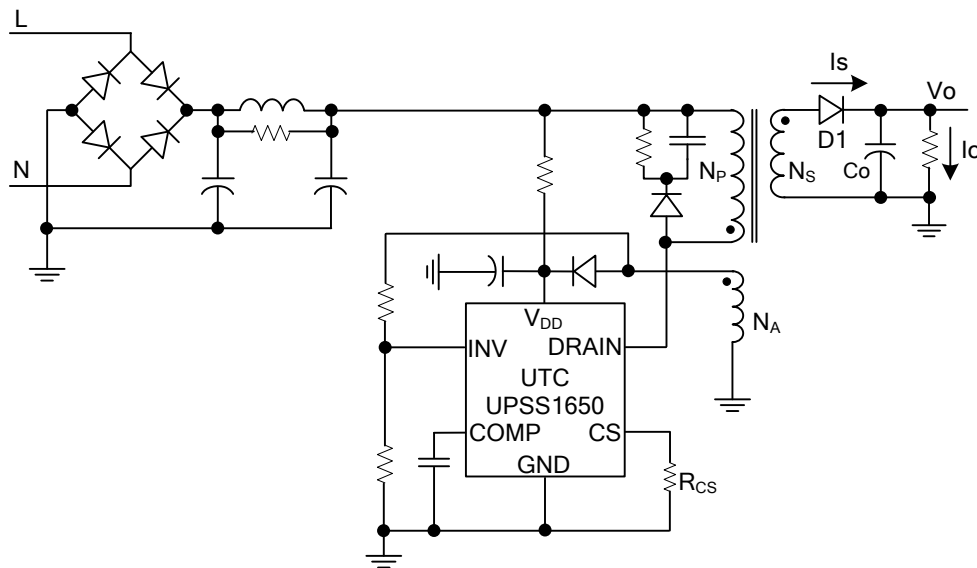

UTC assumes no responsibility for equipment failures that result from using products at values that exceed, even momentarily, rated values (such as maximum ratings, operating condition ranges, or other parameters) listed in products specifications of any and all UTC products described or contained herein. UTC products are not designed for use in life support appliances, devices or systems where malfunction of these products can be reasonably expected to result in personal injury. Reproduction in whole or in part is prohibited without the prior written consent of the copyright owner. The information presented in this document does not form part of any quotation or contract, is believed to be accurate and reliable and may be changed without notice.