



# FET BIAS CONTROLLER

## DESCRIPTION

The UTC **L8001** is specially designed integrated circuit for satellite receiver front-end block. It provides stable drain and gate bias conditions for GaAs or HEMT FETs.

The UTC **L8001**, provide six FETs bias control respectively. By adjusting two external resistors, it can change the FET's bias current to optimize the satellite receiver front end block performances.

It generates the required negative voltage to bias the gate of GaAs FET, and internally provides protection circuit that can protect the FET devices during supply voltage transient. So it is very popular in satellite receiver front end block.

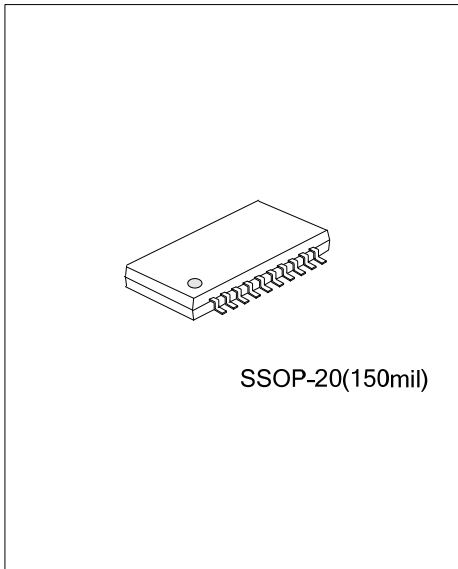

## FEATURES

- \* Built in FET device protection circuit
- \* Adjustable FET device operating current
- \* Stable bias control for GaAs and HEMT FETs
- \* Drive up to six FETs
- \* Wide supply voltage range

## ORDERING INFORMATION

Ordering Number		Package	Packing
Lead Free	Halogen Free		
L8001L-R20-T	L8001G-R20-T	SSOP-20	Tube
L8001L-R20-R	L8001G-R20-R	SSOP-20	Tape Reel

<p>L8001L-R20-T</p> <p>(1) Packing Type</p> <p>(2) Package Type</p> <p>(3) Halogen Free</p>	<p>(1) T: Tube, R: Tape Reel</p> <p>(2) SSOP-20</p> <p>(3) L: Lead Free, G: Halogen Free</p>
---	--

## ■ PIN CONFIGURATION

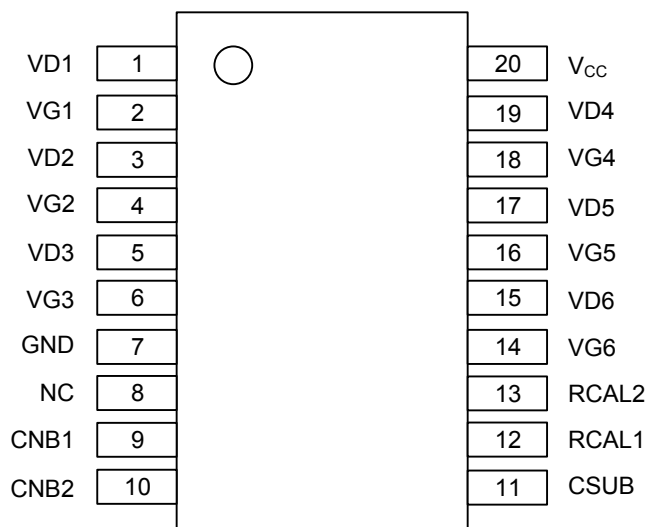

## ■ PIN DESCRIPTION

PIN NO.	PIN NAME	DESCRIPTION
1	VD1	1 <sup>st</sup> Drain output voltage
2	VG1	1 <sup>st</sup> Gate output voltage
3	VD2	2 <sup>nd</sup> Drain output voltage
4	VG2	2 <sup>nd</sup> Gate output voltage
5	VG3	3 <sup>rd</sup> Gate output voltage
6	VD3	3 <sup>rd</sup> Drain output voltage
7	GND	Ground
8	NC	No connect
9	CNB1	OSC output
10	CNB2	Rectifier Input
11	CSUB	Negative voltage output
12	RCAL1	VD1/VD2/VD3 current set resistor connect
13	RCAL2	VD4/VD5/VD6 current set resistor connect
14	VG6	6 <sup>th</sup> Gate output voltage
15	VD6	6 <sup>th</sup> Drain output voltage
16	VG5	5 <sup>th</sup> Gate output voltage
17	VD5	5 <sup>th</sup> Drain output voltage
18	VG4	4 <sup>th</sup> Gate output voltage
19	VD4	4 <sup>th</sup> Drain output voltage
20	V <sub>CC</sub>	Supply voltage



### ■ ABSOLUTE MAXIMUM RATING

PARAMETER	SYMBOL	RATINGS	UNIT
Supply Voltage	$V_{CC}$	-0.6~8	V
Supply Current	$I_{CC}$	100	mA
Maximum Drain Current		15	mA
Maximum CSUB Sink Current		-500	uA
Operating Temperature	$T_{OPR}$	-40~80	°C
Storage Temperature	$T_{STG}$	-50~150	°C

Note: Absolute maximum ratings are those values beyond which the device could be permanently damaged. Absolute maximum ratings are stress ratings only and functional device operation is not implied.

### ■ ELECTRICAL CHARACTERISTICS

( $V_{CC}=3.3V$ ,  $I_D=10mA$ ,  $R_{CAL1}=8.2K\Omega$ ,  $R_{CAL2}=8.2K\Omega$ ,  $T_A=25^\circ C$ , unless otherwise stated)

PARAMETER	SYMBOL	TEST CONDITIONS	MIN	TYP	MAX	UNIT
Supply Voltage	$V_{CC}$		3.3		6	V
Supply Current	$I_{CC}$	No FET			10	mA
Negative Voltage	$V_{SUB}$	$I_{SUB}=0\mu A$ , $V_{CC}=6V$	-3.0	-2.5	-1	V
		$I_{SUB}=-200\mu A$			-1	V
Oscillator Freq.	$f_o$		200	350	800	KHz
Drain Current	$I_D$		8	10	12	mA
Drain Current Change with $V_{CC}$	$\Delta I_{DV}$	$V_{CC}=3.3\sim 6V$		0.2		%/V
VD1/VD2(VD3/VD4) Drain Offset Current	$\Delta I_{DC}$			0.2		mA
Drain Current Change with Temp.	$\Delta I_{DT}$	$T=-40\sim 80^\circ C$		0.1		%/°C
Drain Voltage	$V_D$	$I_D=10mA$	1.8	2	2.2	V
Drain Voltage Change with $V_{CC}$	$\Delta V_{DV}$	$V_{CC}=3.3\sim 6V$		0.5		%/V
Drain Voltage Change	$\Delta V_{DT}$	$T=-40\sim 80^\circ C$		50		ppm
Dynamic Gate Voltage Range	$V_G$	Csub without loading	-2.5		0.7	V
Drain Output Noise Voltage	$V_{dn}$	With drain bypass capacitor=10nF			0.05	$V_{PP}$
Gate Output Noise Voltage	$V_{GN}$	With gate bypass capacitor=10nF			0.03	$V_{PP}$

■ TYPICAL APPLICATION CIRCUIT

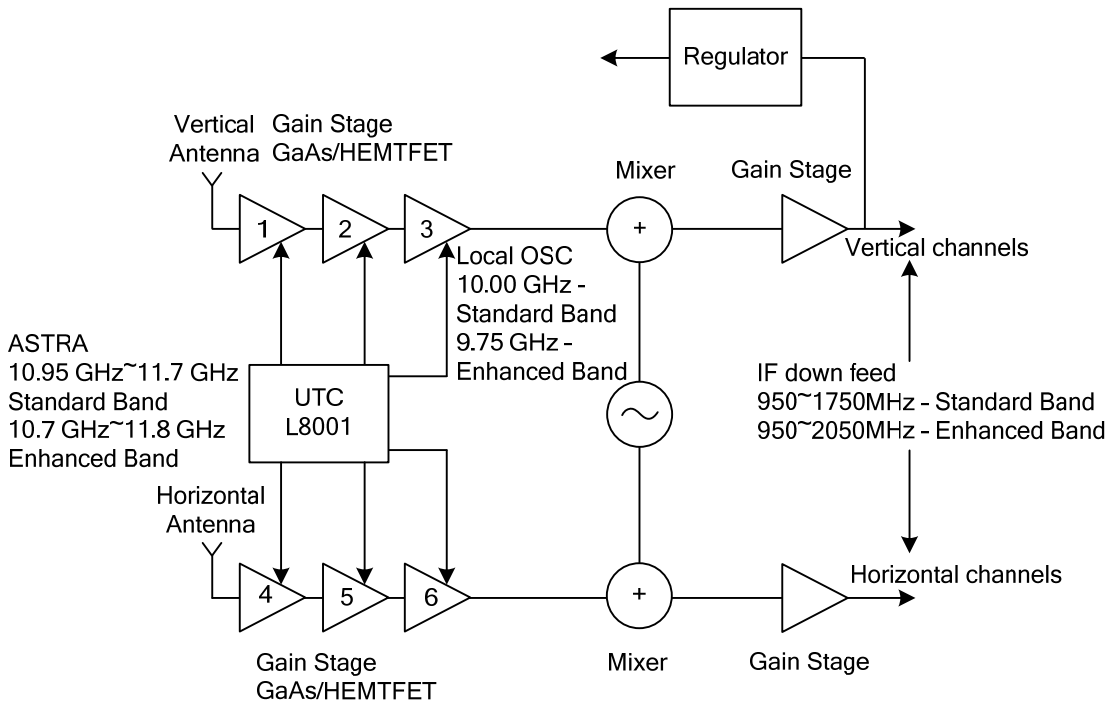

UTC assumes no responsibility for equipment failures that result from using products at values that exceed, even momentarily, rated values (such as maximum ratings, operating condition ranges, or other parameters) listed in products specifications of any and all UTC products described or contained herein. UTC products are not designed for use in life support appliances, devices or systems where malfunction of these products can be reasonably expected to result in personal injury. Reproduction in whole or in part is prohibited without the prior written consent of the copyright owner. The information presented in this document does not form part of any quotation or contract, is believed to be accurate and reliable and may be changed without notice.