



# UCD4015

CMOS IC

## CMOS Dual 4-Stage Static Shift Register

### DESCRIPTION

UCD4015 consists of two identical, independent, 4-stage serial-input/parallel-output registers. Each register has independent CLOCK and RESET input as well as a single serial DATA input. "Q" outputs are available from each of the four stages on both registers. All registers stages are D-type, master-slave flip-flops. The logic level present at the DATA input is transferred into the first register stage and shifted over one stage at each positive-going clock transition. Resetting of all stages is accomplished by a high level on the reset line. Register expansion to 8 stages using one UCD4015 package or to more than 8 stages using additional UCD4015's is possible.

### FEATURES

- \* 12MHz (typ.) clock rate at 10V
- \* Maximum input current of 1µA at 18V
- \* Fully static operation
- \* 8 master-slave flip-flops plus input and output buffering

### APPLICATIONS

- \* General-purpose register
- \* Serial-input/parallel-output data queueing
- \* Serial to parallel data conversion

### ORDERING INFORMATION

Ordering Number		Package	Packing
Lead Free	Halogen Free		
UCD4015L-S16-T	UCD4015G-S16-T	SOP-16	Tube
UCD4015L-S16-R	UCD4015G-S16-R	SOP-16	Tape Reel
UCD4015L-P16-T	UCD4015G-P16-T	TSSOP-16	Tube
UCD4015L-P16-R	UCD4015G-P16-R	TSSOP-16	Tape Reel

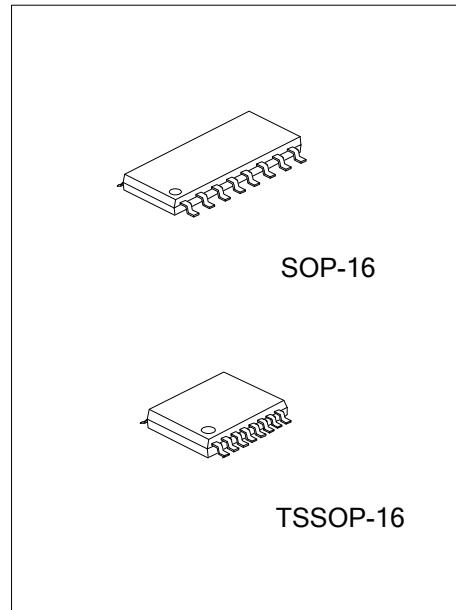

UCD4015L-S16-R	(1) Packing Type	(1) T: Tube, R: Tape Reel
	(2) Package Type	(2) S16: SOP-16, P16: TSSOP-16
	(3) Lead Free	(3) L: Lead Free, G: Halogen Free

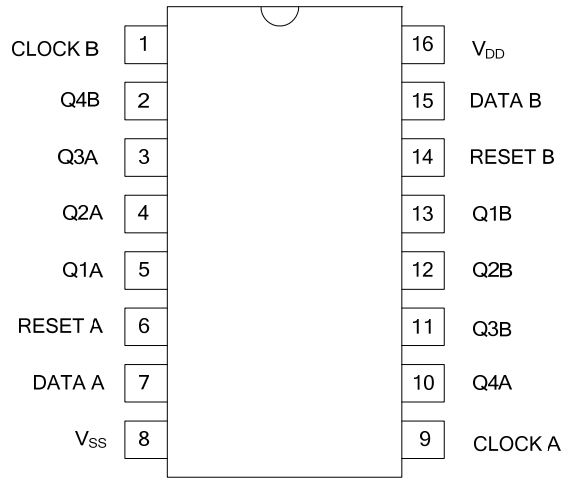

## ■ PIN CONFIGURATION

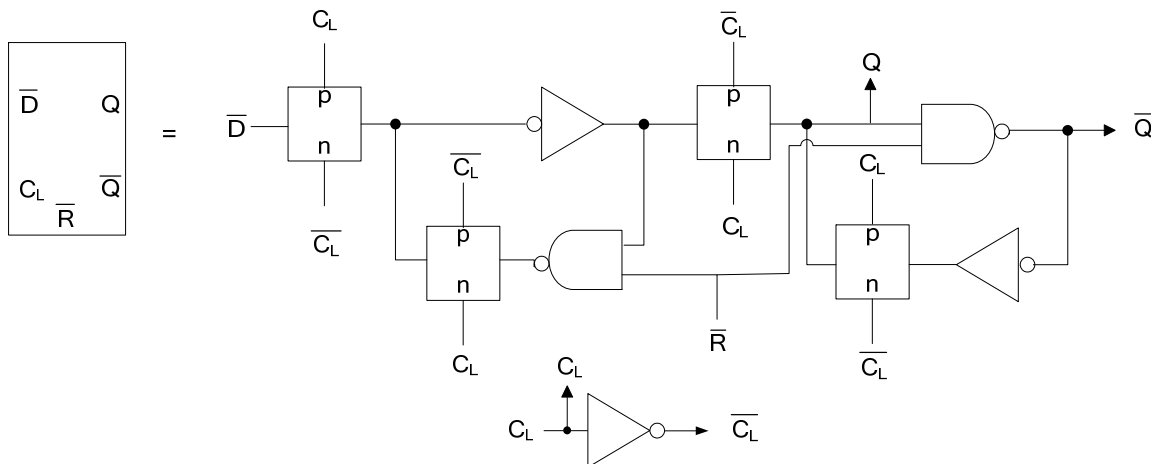
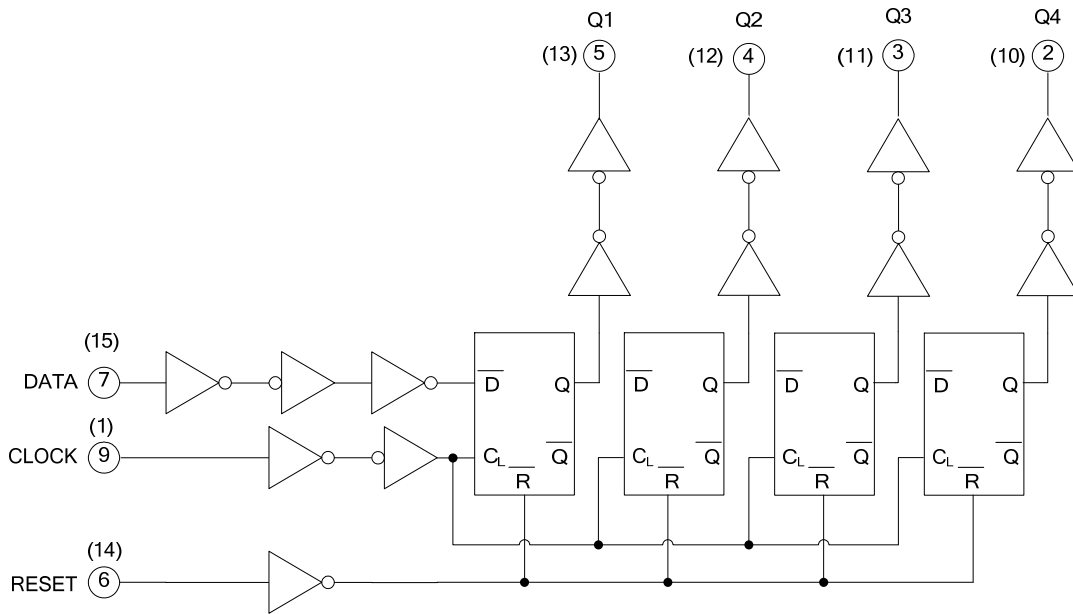

## ■ LOGIC DIAGRAM



■ TRUE TABLE

$C_L$	D	R	$Q_1$	$Q_n$
	0	0	0	$Q_{n-1}$
	1	0	1	$Q_{n-1}$
X	X	1	0	0
	X	0	$Q_1$	$Q_n$ (NC)

Note: X = DON'T CARE CASE, NC = NO CHANGE

■ **ABSOLUTE MAXIMUM RATING** ( $T_A = 25^\circ\text{C}$ , unless otherwise specified)

PARAMETER	SYMBOL	RATINGS	UNIT
Supply Voltage	$V_{DD}$	-0.5 ~ 20	V
Input Voltage	$V_{IN}$	-0.5 ~ $V_{CC} + 0.5$	V
Output Voltage	$V_{OUT}$	-0.5 ~ $V_{CC} + 0.5$	V
Input Clamp Current ( $V_{IN} < 0$ , or $V_{IN} > V_{CC}$ )	$I_{IK}$	$\pm 10$	mA
Power Dissipation	$P_D$	500	mW
Operating Temperature	$T_{OPR}$	-40 ~ +125	$^\circ\text{C}$
Storage Temperature	$T_{STG}$	-65 ~ +150	$^\circ\text{C}$

Note: 1. The input and output voltage ratings may be exceeded if the input and output current ratings are observed.

2. Absolute maximum ratings are those values beyond which the device could be permanently damaged.

Absolute maximum ratings are stress ratings only and functional device operation is not implied.

■ **THERMAL DATA**

PARAMETER	SYMBOL	RATINGS	UNIT
Junction to Ambient	SOP-16	73	$^\circ\text{C/W}$
	TSSOP-16	108	$^\circ\text{C/W}$

■ **RECOMMENDED OPERATING CONDITIONS**

PARAMETER	SYMBOL	CONDITIONS	MIN	TYP	MAX	UNIT
Supply Voltage	$V_{DD}$		3		18	V
Clock Pulse Width	$t_w$	$V_{DD}=5\text{V}$	180			ns
		$V_{DD}=10\text{V}$	80			
		$V_{DD}=15\text{V}$	50			
Clock Frequency	$f_{CL}$	$V_{DD}=5\text{V}$			3	MHz
		$V_{DD}=10\text{V}$			6	
		$V_{DD}=15\text{V}$			8.5	
Clock Rise and Fall Time	$t_r, t_f$	$V_{DD}=5\text{V}$			15	$\mu\text{s}$
		$V_{DD}=10\text{V}$			6	
		$V_{DD}=15\text{V}$			2	
Data Set-up Time	$t_{SU}$	$V_{DD}=5\text{V}$	70			ns
		$V_{DD}=10\text{V}$	40			
		$V_{DD}=15\text{V}$	30			

■ **ELECTRICAL CHARACTERISTICS** ( $T_A = 25^\circ\text{C}$ , unless otherwise specified)

PARAMETER	SYMBOL	TEST CONDITIONS	MIN	TYP	MAX	UNIT
Quiescent Supply Current	$I_{DD}$	$V_{IN}=0, 5\text{V}, V_{DD}=5\text{V}$		0.04	5	$\mu\text{A}$
		$V_{IN}=0, 10\text{V}, V_{DD}=10\text{V}$		0.04	10	
		$V_{IN}=0, 15\text{V}, V_{DD}=15\text{V}$		0.04	20	
		$V_{IN}=0, 20\text{V}, V_{DD}=20\text{V}$		0.08	100	
Output Low (Sink) Current	$I_{OL}$	$V_{OUT}=0.4\text{V}, V_{DD}=5\text{V}$	0.51	1		mA
		$V_{OUT}=0.5\text{V}, V_{DD}=10\text{V}$	1.3	2.6		
		$V_{OUT}=1.5\text{V}, V_{DD}=15\text{V}$	3.4	6.8		
Output High (Source) Current	$I_{OH}$	$V_{OUT}=4.6\text{V}, V_{DD}=5\text{V}$	-0.51	-1		mA
		$V_{OUT}=2.5\text{V}, V_{DD}=5\text{V}$	-1.6	-3.2		
		$V_{OUT}=9.5\text{V}, V_{DD}=10\text{V}$	-1.3	-2.6		
		$V_{OUT}=13.5\text{V}, V_{DD}=15\text{V}$	-3.4	-6.8		
Output Voltage: Low-Level	$V_{OL}$	$V_{DD}=5\text{V}$		0	0.05	V
		$V_{DD}=10\text{V}$		0	0.05	
		$V_{DD}=15\text{V}$		0	0.05	
Output Voltage: High-Level	$V_{OH}$	$V_{DD}=5\text{V}$	4.95	5		V
		$V_{DD}=10\text{V}$	9.95	10		
		$V_{DD}=15\text{V}$	14.95	15		

### ■ ELECTRICAL CHARACTERISTICS(Cont.)

PARAMETER	SYMBOL	TEST CONDITIONS	MIN	TYP	MAX	UNIT
Input Low Voltage	$V_{IL}$	$V_{OUT}=0.5, 4.5V, V_{DD}=5V$			1.5	V
		$V_{OUT}=1, 9V, V_{DD}=10V$			3	
		$V_{OUT}=1.5, 13.5V, V_{DD}=15V$			4	
Input High Voltage	$V_{IH}$	$V_{OUT}=0.5, 4.5V, V_{DD}=5V$	3.5			V
		$V_{OUT}=1, 9V, V_{DD}=10V$	7			
		$V_{OUT}=1.5, 13.5V, V_{DD}=15V$	11			
Input Leakage Current	$I_{I(LEAK)}$	$V_{IN}=0, 18V, V_{DD}=18V$			$\pm 0.1$	$\mu A$

### ■ SWITCHING CHARACTERISTICS ( $T_A=25^\circ C$ , Input $t_r, t_f=20ns$ , $C_L=50pF$ , $R_L=200K\Omega$ )

PARAMETER	SYMBOL	TEST CONDITIONS	MIN	TYP	MAX	UNIT
<b>CLOCKED OPERATION</b>						
Propagation Delay Time	$t_{PLH} / t_{PHL}$	$V_{DD}=5V$		160	320	ns
		$V_{DD}=10V$		80	160	
		$V_{DD}=15V$		60	120	
Transition Time	$t_{THL} / t_{TLH}$	$V_{DD}=5V$		100	200	ns
		$V_{DD}=10V$		50	100	
		$V_{DD}=15V$		40	80	
Maximum Clock Input Frequency	$f_{CL}$	$V_{DD}=5V$	3	6		MHz
		$V_{DD}=10V$	6	12		
		$V_{DD}=15V$	8.5	17		
Minimum Clock Pulse Width	$t_{WCL}$	$V_{DD}=5V$		90	180	ns
		$V_{DD}=10V$		40	80	
		$V_{DD}=15V$		25	50	
Clock Rise and Fall Time	$t_{rCL} / t_{fCL}$	$V_{DD}=5V$			15	$\mu s$
		$V_{DD}=10V$			6	
		$V_{DD}=15V$			2	
Minimum Data Setup Time	$t_{SU}$	$V_{DD}=5V$		35	70	ns
		$V_{DD}=10V$		20	40	
		$V_{DD}=15V$		15	30	
Minimum Data Hold Time	$t_H$	$V_{DD}=5V$			0	ns
		$V_{DD}=10V$			0	
		$V_{DD}=15V$			0	
Average Input Capacitance	$C_i$	Any Input		5	7.5	pF
<b>RESET OPERATION</b>						
Propagation Delay Time	$t_{PLH} / t_{PHL}$	$V_{DD}=5V$		200	400	ns
		$V_{DD}=10V$		100	200	
		$V_{DD}=15V$		80	160	
Minimum Reset Pulse Width	$t_{WR}$	$V_{DD}=5V$		100	200	ns
		$V_{DD}=10V$		40	80	
		$V_{DD}=15V$		30	60	

## ■ TEST CIRCUIT AND WAVEFORMS

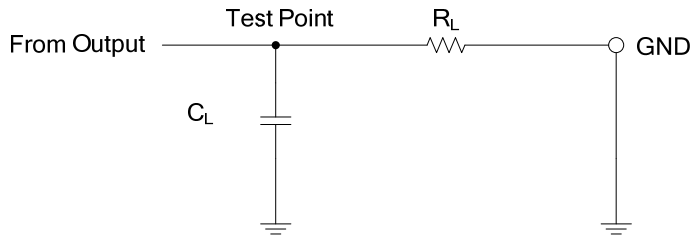

Fig 1. TEST CIRCUIT

Inputs		$V_M$	$V_{LOAD}$	$C_L$	$R_L$
$V_{IN}$	$t_r, t_f$				
$V_{DD}$	20 ns	$V_{DD}/2$	$V_{DD}$	50 pF	200 K $\Omega$

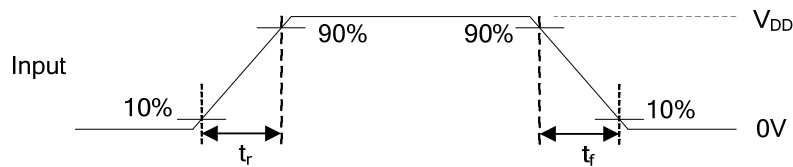

Fig2. VOLTAGE WAVEFORMS INPUT RISE AND FALL TIMES

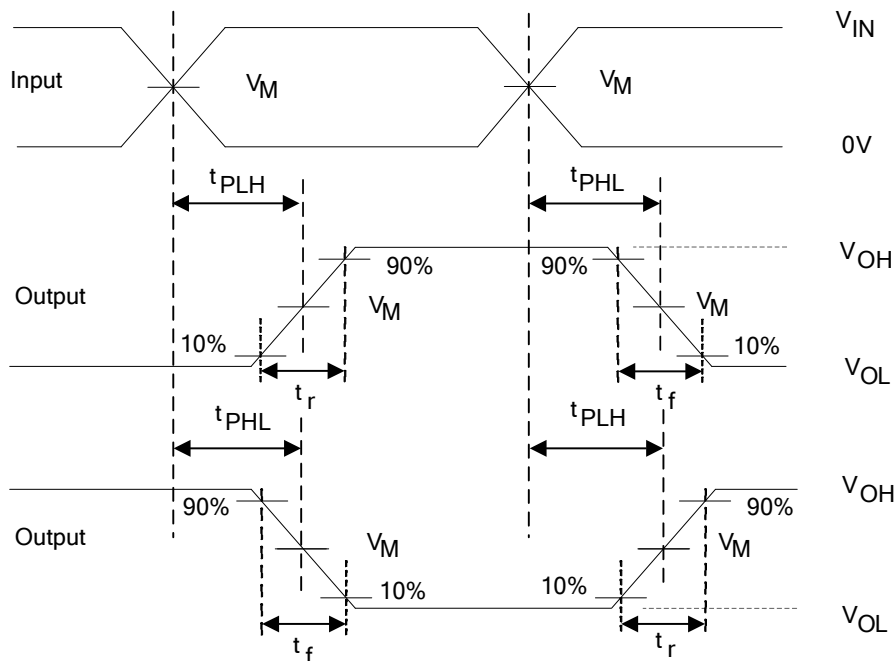

Fig3. VOLTAGE WAVEFORMS PROPAGATION DELAY AND OUTPUT TRANSITION TIMES

- Notes: 1.  $C_L$  includes probe and jig capacitance.  
 2. All input pulses are supplied by generators having the following characteristics: PRR  $\leq$  1MHz,  $Z_O = 50\Omega$ .

■ TEST CIRCUIT AND WAVEFORMS(Cont.)

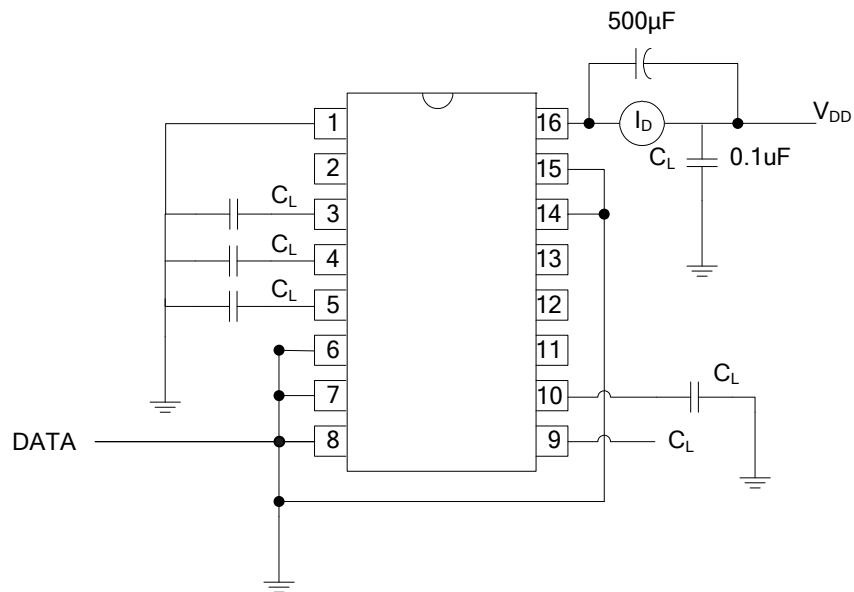

Fig4. Dynamic power dissipation test circuit

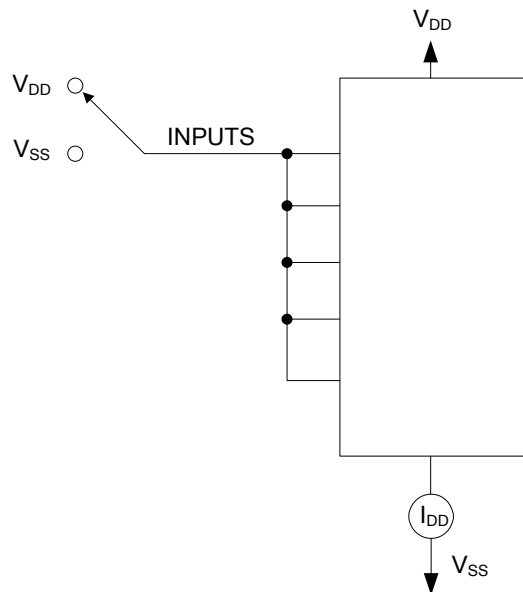

Fig5. Quiescent device current test circuit

■ TEST CIRCUIT AND WAVEFORMS(Cont.)

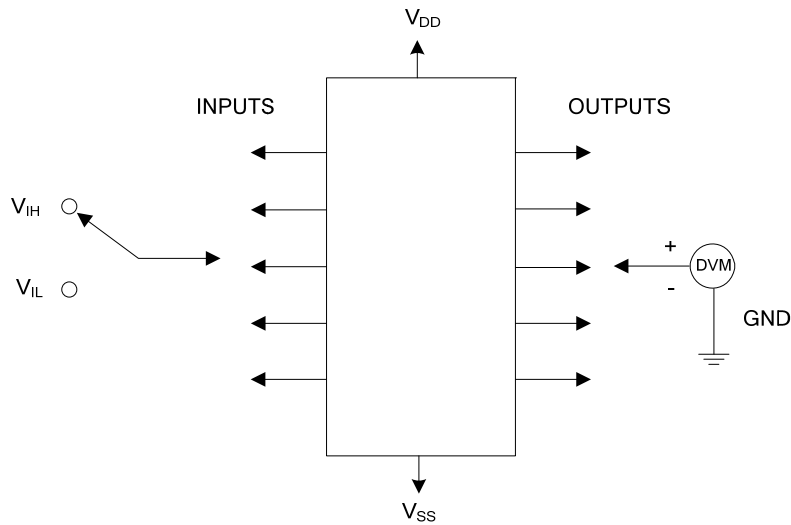

Fig6 Input voltage test circuit

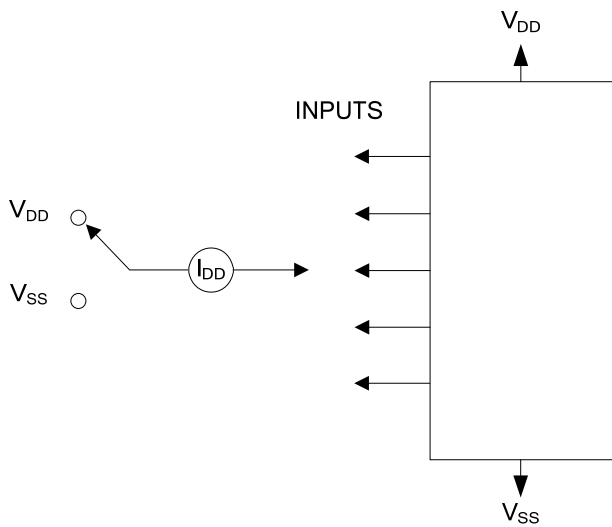

Fig7 Input current test circuit

Note: measure inputs sequentially, to both  $V_{DD}$  and  $V_{SS}$ ; connect all unused inputs to either  $V_{DD}$  or  $V_{SS}$ .

UTC assumes no responsibility for equipment failures that result from using products at values that exceed, even momentarily, rated values (such as maximum ratings, operating condition ranges, or other parameters) listed in products specifications of any and all UTC products described or contained herein. UTC products are not designed for use in life support appliances, devices or systems where malfunction of these products can be reasonably expected to result in personal injury. Reproduction in whole or in part is prohibited without the prior written consent of the copyright owner. The information presented in this document does not form part of any quotation or contract, is believed to be accurate and reliable and may be changed without notice.