

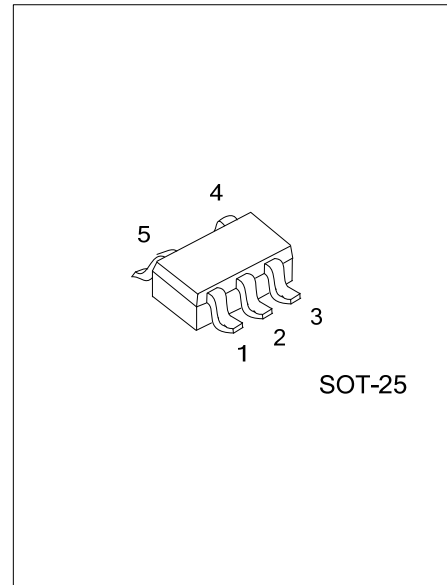

ONE-CELL STANDALONE LINEAR LITHIUM BATTERY CHARGER



DESCRIPTION

UTC **UB6054** is a complete, constant current and constant voltage linear charger for single cell lithium-ion batteries. Its small size and ability to regulate low charge currents make UTC **UB6054** especially well-suited for portable applications using low capacity rechargeable lithium-ion coin cells. Furthermore, UTC **UB6054** is specifically designed to work within USB power specifications.

No external sense resistor is needed, and no blocking diode is required due to the internal MOSFET architecture. The charge voltage is fixed at 4.2V, and the charge current can be programmed externally with a single resistor. UTC **UB6054** automatically terminates a charge cycle when the charge current drops to 1/10th the programmed value after the final float voltage is reached.

FEATURES

- * Programmable Charge Current Up to 500mA.
- * No External MOSFET, Sense Resistor or Blocking Diode Required.
- * Complete linear charger in ThinSOT Package for Single Cell / Coin Cell Lithium-Ion Batteries.
- * Constant Current / Constant Voltage Operation with Thermal Regulation to Maximize Charge Rate Without Risk of Overheating.
- * Charges Single Cell Li-Ion Batteries Directly form USB Port.
- * Preset 4.2V Charge Voltage with High Accuracy about ±1.2%.
- * Automatic Recharge.
- * 2.9V Trickle Charge Threshold.
- * 20µA Supply Current in Shutdown Mode.
- * Available in a SOT-25 Pacakage.
- * Charge Status Output Pin.

ORDERING INFORMATION

Ordering Number		Package	Packing
Lead Free	Halogen Free		
UB6054L-AF5-R	UB6054G-AF5-R	SOT-25	Tape Reel

Note: xx: Output Voltage, refer to Marking Information.

UB6054G-xx-AF5-R	(1)Packing Type	(1) R: Tape Reel
	(2)Package Type	(2) AF5: SOT-25
	(3)Output Voltage Code	(3) xx: Refer to Marking Information
	(4)Halogen Free	(4) G: Halogen Free, L: Lead Free

■ MARKING INFORMATION

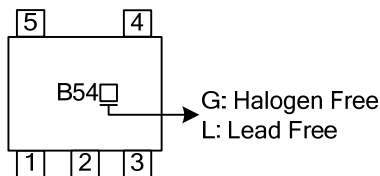

■ PIN CONFIGURATION

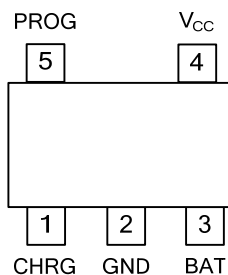

■ PIN DESCRIPTION

PIN NO.	PIN NAME	DESCRIPTION
1	CHRG	Open-Drain Charge Status Output. When the battery is charging, the CHRG pin is pulled low by an internal N-channel MOSFET. When the charge cycle is completed, a weak pull-down of approximately 20uA is connected to the CHRG pin, indicating an “AC present” condition.
2	GND	Ground.
3	BAT	Charge Current Output. Provides charge current to the battery and regulates the final float voltage to 4.2V.
4	V _{CC}	Positive Input Supply Voltage. Provides power to the charger. V _{CC} can range from 4.25V to 6.5V and should be bypassed with at least a 1μF capacitor.
5	PROG	Charge Current Program, Charge Current Monitor and Shutdown Pin.

■ BLOCK DIAGRAM

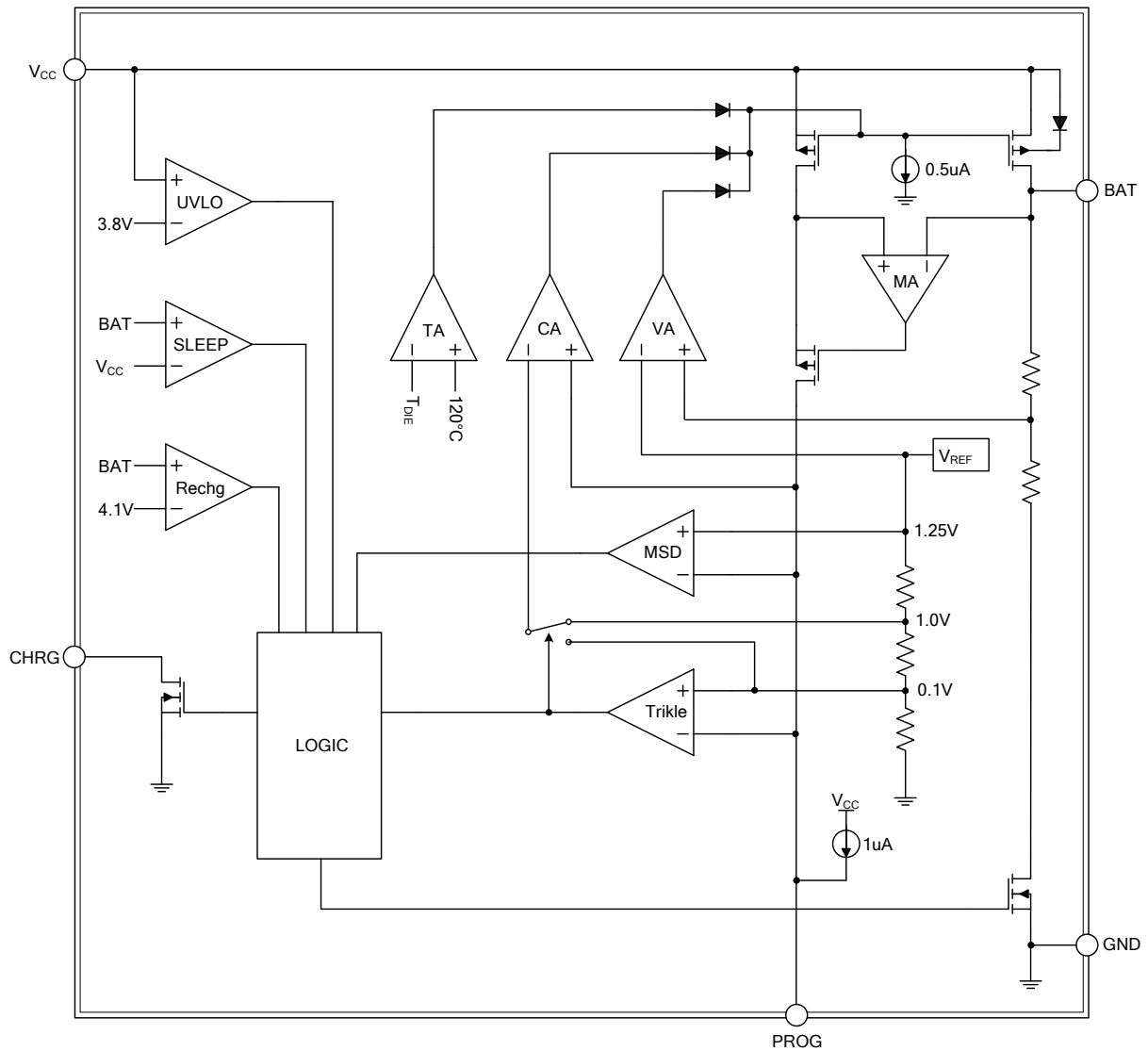

■ ABSOLUTE MAXIMUM RATING

PARAMETER	SYMBOL	RATINGS	UNIT
Input Supply Voltage	V_{CC}	-0.3 ~ +7.0	V
PROG Voltage	V_{PROG}	-0.3 ~ +7.0	V
BAT Voltage	V_{BAT}	-0.3 ~ +7.0	V
CHRG Voltage	V_{CHRG}	-0.3 ~ +7.0	V
BAT Short-Circuit Duration		Continuous	
Thermal Resistance, Junction-to-Ambient	θ_{JA}	250	°C/W
BAT Pin Current	I_{BAT}	500	mA
PROG Pin Current	I_{PROG}	500	μA
Maximum Junction Temperature	T_J	125	°C
Operating Ambient Temperature Range	T_{OPR}	-40 ~ +85	°C
Storage Temperature	T_{STG}	-65 ~ +125	°C

Notes: 1. Absolute maximum ratings are those values beyond which the device could be permanently damaged.

Absolute maximum ratings are stress ratings only and functional device operation is not implied.

2. Pulse (μsec) noise exceeding the above input voltage (GND+7.0V) may cause damage to the IC.

■ ELECTRICAL CHARACTERISTICS ($V_{CC}=5V$, $T_A=25^{\circ}C$, unless otherwise specified)

PARAMETER	SYMBOL	TEST CONDITIONS	MIN	TYP	MAX	UNIT
Input Supply Voltage	V_{CC}		4.5		6.0	V
Input Supply Current	I_{CC}	Charge Mode (Note 1), $R_{PROG}=10k$		300	2000	μA
		Standby Mode (Charge Terminated)		200	500	μA
		Shutdown Mode (R_{PROG} Not Connected, $V_{CC}<V_{BAT}$, or $V_{CC}<V_{UV}$)		25	60	μA
Regulated Output (Float) Voltage	V_{FLOAT}	$I_{BAT}=30mA$, $I_{CHRG}=5mA$	4.15	4.20	4.25	V
BAT Pin Current	I_{BAT}	$R_{PROG}=10k$, Current Mode	80	100	120	mA
		$R_{PROG}=2k$, Current Mode		500		mA
		Standby Mode, $V_{BAT}=4.2V$		± 1	± 6	μA
		Shutdown Mode (R_{PROG} Not Connected)		± 1	± 6	μA
		Sleep Mode, $V_{CC}=0V$		± 1	± 6	μA
Trickle Charge Current	I_{TRIKL}	$V_{BAT}<V_{TRIKL}$, $R_{PROG}=10k$		10		mA
Trickle Charge Threshold Voltage	V_{TRIKL}	$R_{PROG}=10k$, V_{BAT} Rising	2.8	2.9	3.0	V
V_{CC} Undervoltage Lockout Threshold	V_{UV}	From V_{CC} Low to High		3.8		V
V_{CC} Undervoltage Lockout Hysteresis	V_{UVHYS}			120		mV
Manual Shutdown Threshold Voltage	V_{MSD}	PROG Pin Rising		1.25		V
		PROG Pin Falling		1.15		V
$V_{CC}-V_{BAT}$ Lockout Threshold Voltage	V_{ASD}	V_{CC} from Low to High		100		mV
		V_{CC} from High to Low		30		mV
C/10 Termination Current Threshold	I_{TERM}	$R_{PROG}=10k$ (Note2)		0.1		mA/mA
		$R_{PROG}=2k$		0.1		mA/mA
PROG Pin Voltage	V_{PROG}	$R_{PROG}=10k$, Current Mode	0.8	1.0	1.2	V
CHRG Pin Weak Pull-Down Current	I_{CHRG}	$V_{CHRG}=3V$		20		μA
CHRG Pin Output Low Voltage	V_{CHRG}	$I_{CHRG}=5mA$		0.6		V
Recharge Battery Threshold Voltage	ΔV_{RECHRG}	$V_{FLOAT}-V_{RECHRG}$		150		mV
Thermal Protection Temperature	T_{LIM}			120		$^{\circ}C$
Power FET "ON" Resistance (Between V_{CC} and BAT)	R_{ON}			0.6		Ω
Soft-Start Time	t_{SS}	$I_{BAT}=0$ to $1000V/R_{PROG}$		100		μs
Recharge Comparator Filter Time	$t_{RECHARGE}$	V_{BAT} High to Low		1.0		ms
Termination Comparator Filter Time	t_{TERM}			1000		μs
PROG Pin Pull-Up Current	I_{PROG}			1.0		μA

Notes: 1. Supply current includes PROG pin current (approximately $100\mu A$) but does not include any current delivered to the battery through the BAT pin (approximately $100mA$).

2. I_{TERM} is expressed as a fraction of measured full charge current with indicated PROG resistor.

■ OPERATION

The UTC **UB6054** is a single cell lithium-ion battery charger using a constant-current/constant-voltage algorithm. It can deliver up to 500mA of charge current (using a good thermal PCB layout) with a final float voltage accuracy of $\pm 1.2\%$. The UTC **UB6054** includes an internal P-channel power MOSFET and thermal regulation circuitry. No blocking diode or external current sense resistor is required; thus, the basic charger circuit requires only two external components. Furthermore, the UTC **UB6054** is capable of operating from a USB power source.

1. Normal Charge Cycle

A charge cycle begins when the voltage at the V_{CC} pin rises above the UVLO threshold level and a 1% program resistor is connected from the PROG pin to ground or when a battery is connected to the charger output. If the BAT pin is less than 2.9V, the charger enters trickle charge mode. In this mode, the UTC **UB6054** supplies approximately 1/10 the programmed charge current to bring the battery voltage up to a safe level for full current charging. When the BAT pin voltage rises above 2.9V, the charger enters constant-current mode, where the programmed charge current is supplied to the battery. When the BAT pin approaches the final float voltage (4.2V), the UTC **UB6054** enters constant-voltage mode and the charge current begins to decrease. The charge cycle ends when the charge current drops to 1/10 of the programmed value.

2. Programming Charge Current

The charge current is programmed using a single resistor from the PROG pin to ground. The battery charge current is 1100 times the current out of the PROG pin. The program resistor and the charge current are calculated using the following equations:

$$R_{\text{PROG}} = \frac{1000V}{I_{\text{CHG}}}, \quad I_{\text{CHG}} = \frac{1000V}{R_{\text{PROG}}}$$

The charge current out of the BAT pin can be determined at any time by monitoring the PROG pin voltage using the following equation:

$$I_{\text{BAT}} = \frac{V_{\text{PROG}}}{R_{\text{PROG}}} \times 1000$$

This actual current will vary from IC to IC. The typical variation is within $\pm 20\%$.

3. Charge Termination

A charge cycle is terminated when the charge current falls to 1/10th the programmed value after the final float voltage is reached. This condition is detected by using an internal, filtered comparator to monitor the PROG pin. When the PROG pin voltage falls below 100mV for longer than t_{TERM} (typically 1ms), charging is terminated. The charge current is latched off and the UTC **UB6054** enters standby mode, where the input supply current drops to 200mA. (Note: C/10 termination is disabled in trickle charging and thermal limiting modes).

When charging, transient loads on the BAT pin can cause the PROG pin to fall below 100mV for short periods of time before the DC charge current has dropped to 1/10th the programmed value. The 1ms filter time (t_{TERM}) on the termination comparator ensures that transient loads of this nature do not result in premature charge cycle termination. Once the average charge current drops below 1/10th the programmed value, the UTC **UB6054** terminates the charge cycle and ceases to provide any current through the BAT pin. In this state, all loads on the BAT pin must be supplied by the battery. The UTC **UB6054** constantly monitors the BAT pin voltage in standby mode. If this voltage drops below the 4.1V recharge threshold (V_{RECHRG}), another charge cycle begins and current is once again supplied to the battery. To manually restart a charge cycle in standby mode, the input voltage must be removed and reapplied, or the charger must be shut down and restarted using the PROG pin.

■ OPERATION(Cont.)

4. Charge Status Indicator (CHRG)

The charge status output has three different states: strong pull-down (~10mA), weak pull-down (~20 μ A) and high impedance. The strong pull-down state indicates that the UTC **UB6054** is in a charge cycle. Once the charge cycle has terminated, the pin state is determined by undervoltage lockout conditions. A weak pull-down indicates that V_{CC} meets the UVLO conditions and the UTC **UB6054** is ready to charge. High impedance indicates that the UTC **UB6054** is in undervoltage lockout mode: either V_{CC} is less than 100mV above the BAT pin voltage or insufficient voltage is applied to the V_{CC} pin.

5. Thermal Limiting

An internal thermal feedback loop reduces the programmed charge current if the die temperature attempts to rise above a preset value of approximately 120°C. This feature protects the UTC **UB6054** from excessive temperature and allows the user to push the limits of the power handling capability of a given circuit board without risk of damaging the UTC **UB6054**. The charge current can be set according to typical (not worst-case) ambient temperature with the assurance that the charger will automatically reduce the current in worst-case conditions.

6. Undervoltage Lockout (UVLO)

An internal undervoltage lockout circuit monitors the input voltage and keeps the charger in shutdown mode until V_{CC} rises above the undervoltage lockout threshold. The UVLO circuit has a built-in hysteresis of 120mV. Furthermore, to protect against reverse current in the power MOSFET, the UVLO circuit keeps the charger in shutdown mode if V_{CC} falls to within 30mV of the battery voltage. If the UVLO comparator is tripped, the charger will not come out of shutdown mode until V_{CC} rise 100mV above the battery voltage.

■ APPLICATION INFORMATION

Stability Considerations

The constant-voltage mode feedback loop is stable without an output capacitor provided a battery is connected to the charger output. With no battery present, an output capacitor is recommended to reduce ripple voltage. When using high value, low ESR ceramic capacitors, it is recommended to add a 1W resistor in series with the capacitor. No series resistor is needed if tantalum capacitors are used. In constant-current mode, the PROG pin is in the feedback loop, not the battery. The constant-current mode stability is affected by the impedance at the PROG pin. With no additional capacitance on the PROG pin, the charger is stable with program resistor values as high as 20kΩ. However, additional capacitance on this node reduces the maximum allowed program resistor thus it should be avoided. Average, rather than instantaneous, charge current may be of interest to the user. For example, if a switching power supply operating in low current mode is connected in parallel with the battery, the average current being pulled out of the BAT pin is typically of more interest than the instantaneous current pulses. In such a case, a simple RC filter can be used on the PROG pin to measure the average battery current as shown in Figure 1. A 10kΩ resistor has been added between the PROG pin and the filter capacitor to ensure stability.

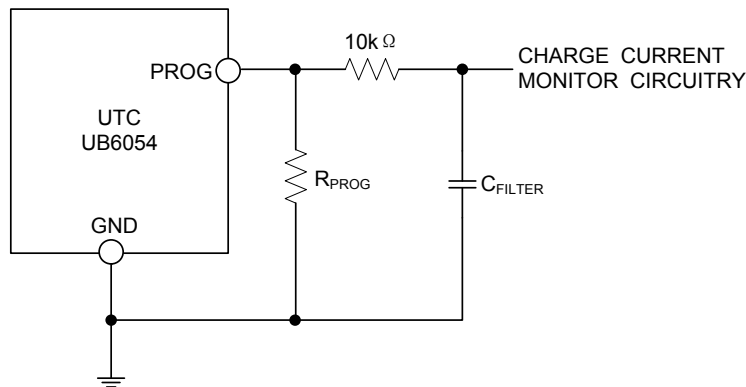

Fig1. Isolating Capacitive Load on PROG Pin

Thermal Limiting

An internal thermal feedback loop reduces the programmed charge current if the die temperature attempts to rise above a preset value of approximately 120°C. This feature protects the **UTC UB6054** from excessive temperature and allows the user to push the limits of the power handling capability of a given circuit board without risk of damaging the **UTC UB6054**. The charge current can be set according to typical (not worst-case) ambient temperature with the assurance that the charger will automatically reduce the current in worst-case conditions. The conditions that cause the **UTC UB6054** to reduce charge current through thermal feedback can be approximated by considering the power dissipated in the IC. Nearly all of this power dissipation is generated by the internal MOSFET. This is calculated to be approximately:

$$P_D = (V_{CC} - V_{BAT}) \times I_{BAT}$$

Where PD is the power dissipated, V_{CC} is the input supply voltage, V_{BAT} is the battery voltage and I_{BAT} is the charge current. The approximate ambient temperature at which the thermal feedback begins to protect the IC is:

$$T_A = 120^\circ\text{C} - P_D \times \theta_{JA}$$

$$T_A = 120^\circ\text{C} - (V_{CC} - V_{BAT}) \times I_{BAT} \times \theta_{JA}$$

Moreover, when thermal feedback reduces the charge current, the voltage at the PROG pin is also reduced proportionally as discussed in the Operation section. It is important to remember that **UTC UB6054** applications do not need to be designed for worst-case thermal conditions since the IC will automatically reduce power dissipation when the junction temperature reaches approximately 120°C.

■ APPLICATION INFORMATION(Cont.)

Thermal Considerations

Because of the small size of the ThinSOT package, it is very important to use a good thermal PC board layout to maximize the available charge current. The thermal path for the heat generated by the IC is from the die to the copper lead frame, through the package leads, (especially the ground lead) to the PC board copper. The PC board copper is the heat sink. The footprint copper pads should be as wide as possible and expand out to larger copper areas to spread and dissipate the heat to the surrounding ambient. Feed-through vias to inner or backside copper layers are also useful in improving the overall thermal performance of the charger. Other heat sources on the board, not related to the charger, must also be considered when designing a PC board layout because they will affect overall temperature rise and the maximum charge current. The following table lists thermal resistance for several different board sizes and copper areas. All measurements were taken in still air on 3/32" FR-4 board with the device mounted on topside.

Table 1 Measured Thermal Resistance on 2-Layer Board (Note 1)

COPPER AREA		BOARD AREA	THERMAL RESISTANCE (θ_{JA}) JUNCTION-TO-AMBIENT
TOPSIDE	BACKSIDE		
2500mm ²	2500mm ²	2500mm ²	125°C/W
1000mm ²	2500mm ²	2500mm ²	125°C/W
225mm ²	2500mm ²	2500mm ²	130°C/W
100mm ²	2500mm ²	2500mm ²	135°C/W
50mm ²	2500mm ²	2500mm ²	150°C/W

Note: 1. Each layer uses one ounce copper

Table 2 Measured Thermal Resistance on 4-Layer Board (Note 1)

COPPER AREA (EACH SIDE)	BOARD AREA	THERMAL RESISTANCE (θ_{JA}) JUNCTION-TO-AMBIENT
2500mm ² (Note 2)	2500mm ²	80°C/W

Notes: 1. Top and bottom layers use two ounce copper, inner layer use one ounce copper
 2. 10,000mm² total copper area

Increasing Thermal Regulation Current

Reducing the voltage drop across the internal MOSFET can significantly decrease the power dissipation in the IC. This has the effect of increasing the current delivered to the battery during thermal regulation. One method is by dissipating some of the power through an external component, such as a resistor or diode. While this application delivers more energy to the battery and reduces charge time in thermal mode, it may actually lengthen charge time in voltage mode if V_{CC} becomes low enough to put the UTC UB6054 into dropout. Figure 2 shows how this circuit can result in dropout as R_{CC} becomes large. This technique works best when R_{CC} values are minimized to keep component size small and avoid dropout. Remember to choose a resistor with adequate power handling capability.

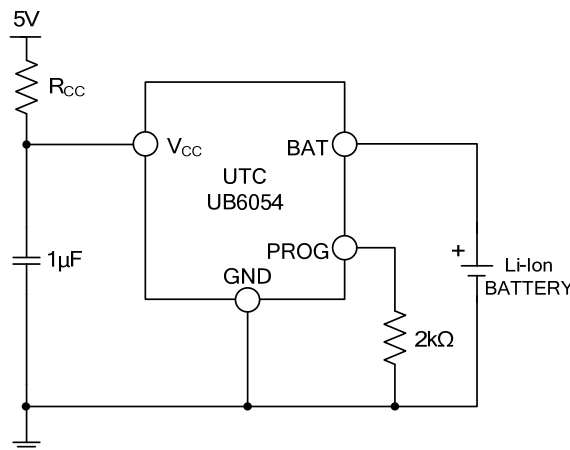

Fig2. A Circuit to Maximize Thermal Mode Charge Current

■ APPLICATION INFORMATION(Cont.)

V_{CC} Bypass Capacitor

Many types of capacitors can be used for input bypassing. However, caution must be exercised when using multilayer ceramic capacitors. Because of the self-resonant and high Q characteristics of some types of ceramic capacitors, high voltage transients can be generated under some start-up conditions, such as connecting the charger input to a live power source. Adding a 1 W resistor in series with an X5R ceramic capacitor will minimize start-up voltage transients.

Charge Current Soft-Start

The UTC **UB6054** includes a soft-start circuit to minimize the inrush current at the start of a charge cycle. When a charge cycle is initiated, the charge current ramps from zero to the full-scale current over a period of approximately 50ms. This has the effect of minimizing the transient current load on the power supply during start-up.

CHRG Status Output Pin

The CHRG pin can provide an indication that the input voltage is greater than the undervoltage lockout threshold level. A weak pull-down current of approximately 20mA indicates that sufficient voltage is applied to V_{CC} to begin charging. When a discharged battery is connected to the charger, the constant current portion of the charge cycle begins and the CHRG pin pulls to ground. The CHRG pin can sink up to 10mA to drive an LED that indicates that a charge cycle is in progress. When the battery is nearing full charge, the charger enters the constant-voltage portion of the charge cycle and the charge current begins to drop. When the charge current drops below 1/10 of the programmed current, the charge cycle ends and the strong pull-down is replaced by the 20mA pull-down, indicating that the charge cycle has ended. If the input voltage is removed or drops below the undervoltage lockout threshold, the CHRG pin becomes high impedance. Figure 3 shows that by using two different value pull-up resistors, a microprocessor can detect all three states from this pin. To detect when the UTC **UB6054** is in charge mode, force the digital output pin (OUT) high and measure the voltage at the CHRG pin. The N-channel MOSFET will pull the pin voltage low even with the 2kΩ pull-up resistor. Once the charge cycle terminates, the N-channel MOSFET is turned off and a 20mA current source is connected to the CHRG pin. The IN pin will then be pulled high by the 2kΩ pull-up resistor. To determine if there is a weak pull-down current, the OUT pin should be forced to a high impedance state. The weak current source will pull the IN pin low through the 800kΩ resistor; if CHRG is high impedance, the IN pin will be pulled high, indicating that the part is in a UVLO state.

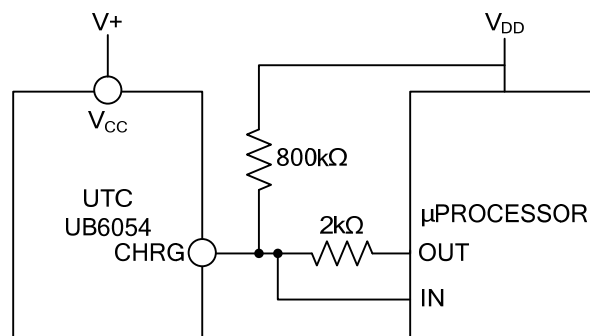

Fig3. Using a Microprocessor to Determine CHRG State

■ APPLICATION INFORMATION(Cont.)

Reverse Polarity Input Voltage Protection

In some applications, protection from reverse polarity voltage on V_{CC} is desired. If the supply voltage is high enough, a series blocking diode can be used. In other cases, where the voltage drop must be kept low a Pchannel MOSFET can be used.

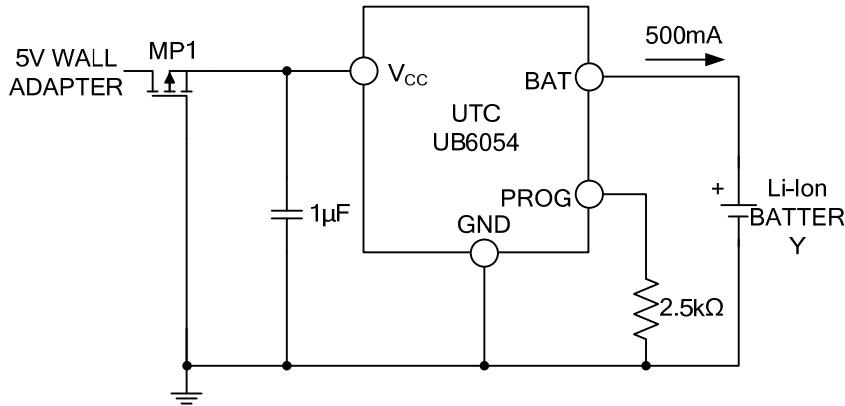

Fig4. Low Loss Input Reverse Polarity Protection

USB and Wall Adapter Power

The UTC **UB6054** allows charging from both a wall adapter and a USB port. Figure 5 shows an example of how to combine wall adapter and USB power inputs. A P-channel MOSFET, MP1, is used to prevent back conducting into the USB port when a wall adapter is present and a Schottky diode, D1, is used to prevent USB power loss through the 1kΩ pull-down resistor. Typically a wall adapter can supply more current than the 500mA-limited USB port. Therefore, an N-channel MOSFET, MN1, and an extra 10kΩ program resistor are used to increase the charge current to 600mA when the wall adapter is present.

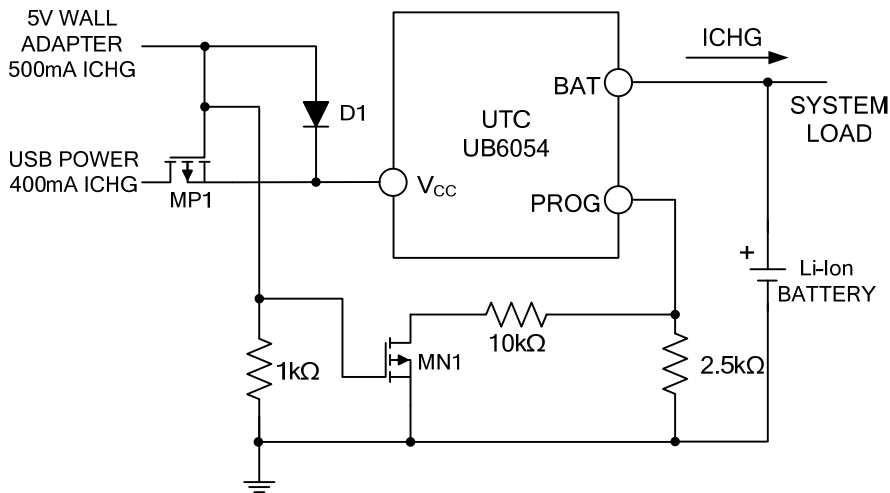

Fig5. Combining Wall Adapter and USB Power

■ TYPICAL APPLICATION CIRCUIT

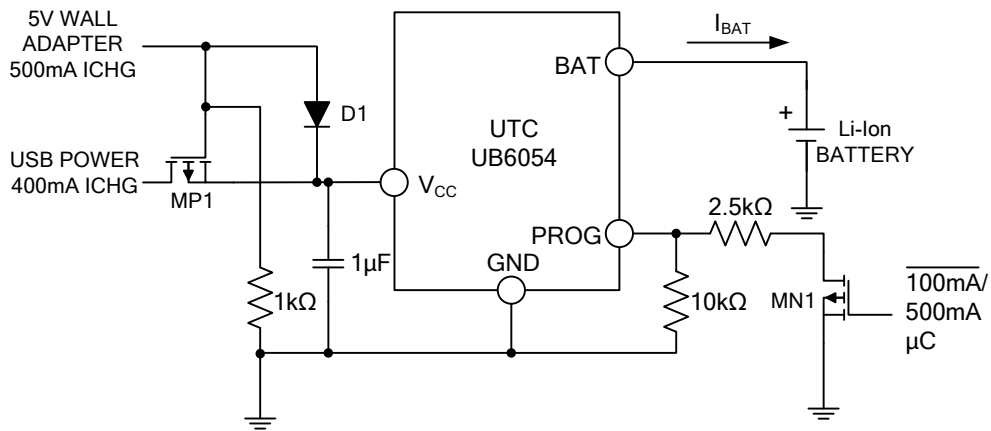

Fig1. USB/Wall Adapter Power Li-Ion Charger

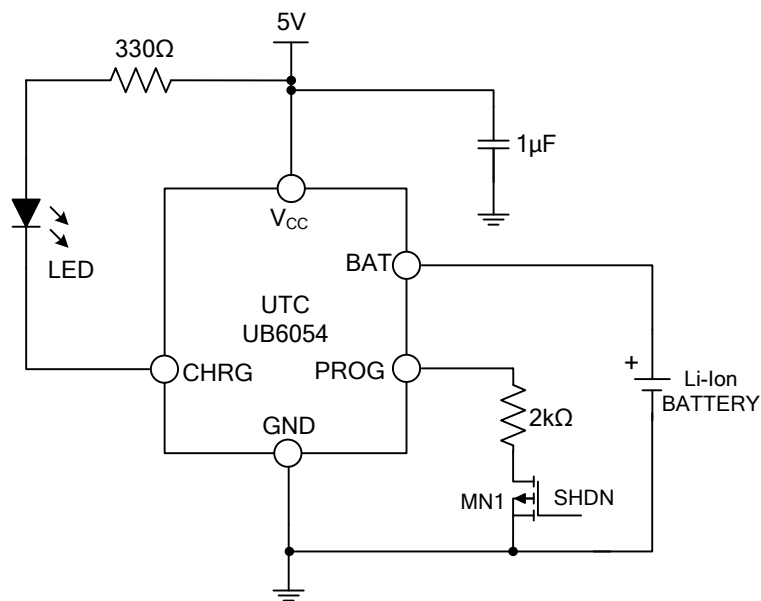

Fig2. Full Featured Single Cell Li-Ion Charger

■ TYPICAL APPLICATION CIRCUIT(Cont.)

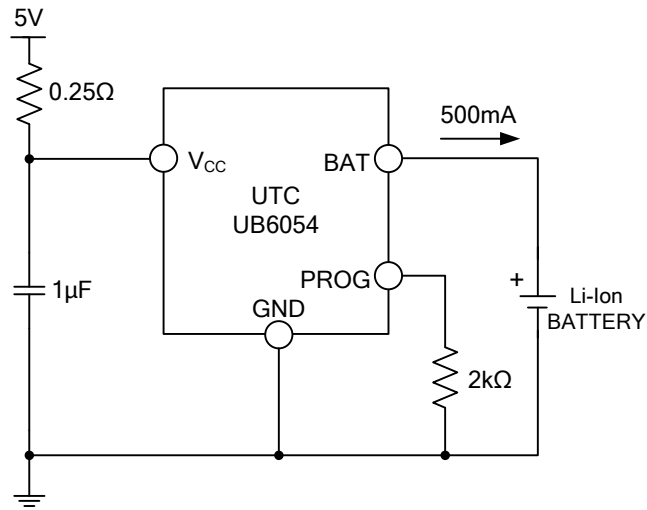

Fig3. 500mA Li-Ion Charger with External Power Dissipation

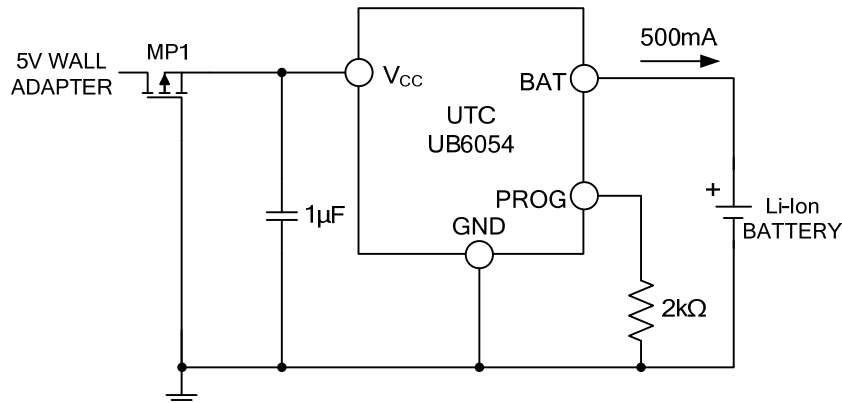

Fig4. Basic Li-Ion Charger with Reverse Polarity Input Protection

UTC assumes no responsibility for equipment failures that result from using products at values that exceed, even momentarily, rated values (such as maximum ratings, operating condition ranges, or other parameters) listed in products specifications of any and all UTC products described or contained herein. UTC products are not designed for use in life support appliances, devices or systems where malfunction of these products can be reasonably expected to result in personal injury. Reproduction in whole or in part is prohibited without the prior written consent of the copyright owner. The information presented in this document does not form part of any quotation or contract, is believed to be accurate and reliable and may be changed without notice.