



UB264A

Preliminary

CMOS IC

LION BATTERY PROTECTION IC FOR 2-SERIAL, 3-SERIAL, OR 4-SERIAL-CELL PACK (SECONDARY PROTECTION)

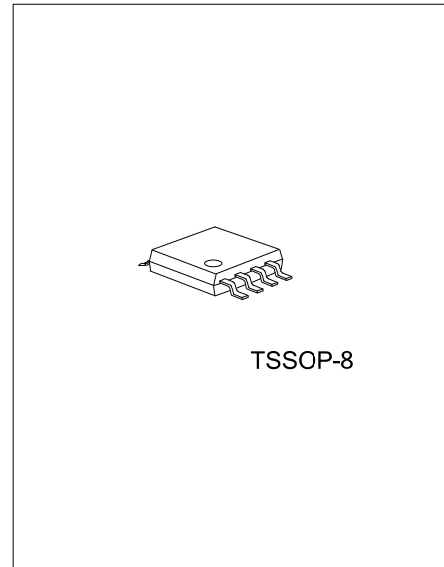

DESCRIPTION

The UTC UB264A Series is secondary protection IC for 2-, 3-, or 4-Cell lithium-ion rechargeable battery packs, and incorporates a high-accuracy voltage detection circuit.

The UTC UB264A Series also includes a high accuracy delay circuit for over voltage detection time without external capacitors.

FEATURES

- \* High-accuracy voltage detection circuit for each cell
\* Overcharge detection voltage n (n=1 to 4): 4.30V to 4.80V (in 50mV steps)
\* Overcharge hysteresis voltage n (n=1 to 4): -0.52V±0.21V, -0.39V±0.16V, -0.26V±0.11V, -0.13V±0.06V, None
\* Delay times for overcharge detection can be set by an internal circuit without external capacitors
\* Output control function via CTL pin
\* CMOS output active "H"
\* Wide operating voltage range 3.6V to 24V
\* Wide operating temperature range -40°C ~ +85°C
\* Low current consumption: 2.5µA typ. (+25°C) at 3.5V for each cell

ORDERING INFORMATION

Table with columns: Ordering Number (Lead Free, Halogen Free), Package (TSSOP-8), Packing (Tape Reel)

Note: xx: SERIAL CODE, refer SERIAL CODE LIST.

Table explaining UB264AG-xx-P08-R components: (1)Packing Type, (2)Package Type, (3)SERIAL CODE, (4)Halogen Free

## ■ PIN CONFIGURATION

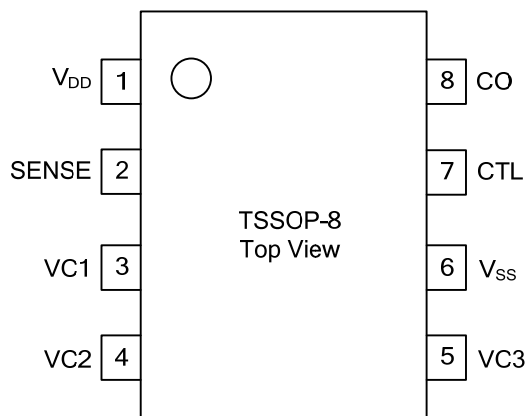

## ■ PIN DESCRIPTION

PIN NO.	PIN NAME	DESCRIPTION
1	V <sub>DD</sub>	Positive power input pin
2	SENSE	Positive voltage connection pin of battery 1
3	VC1	Negative voltage connection pin of battery 1 Positive voltage connection pin of battery 2
4	VC2	Negative voltage connection pin of battery 2 Positive voltage connection pin of battery 3
5	VC3	Negative voltage connection pin of battery 3 Positive voltage connection pin of battery 4
6	V <sub>SS</sub>	Negative power input pin Negative voltage connection pin of battery 4
7	CTL	CO output control pin
8	CO	FET gate connection pin for charge

## ■ SERIAL CODE LIST

MODEL	CODE	OVERCHARGE DETECTION VOLTAGE [V <sub>CU</sub> ](V)	OVERCHARGE HYSTERSIS VOLTAGE [V <sub>HC</sub> ](V)	OVERCHARGE DETECTION DELAY TIME [t <sub>CU</sub> ](S)	OVERCHARGE RELEASE DELAY TIME [t <sub>CL</sub> ](mS)	OUTPUT FORM
UB264A	AA	4.45±0.050	-0.39±0.16	4.0±1.0	60.0±20.0	CMOS output active "H"
	AB	4.35±0.050	-0.39±0.16	4.0±1.0	60.0±20.0	CMOS output active "H"
	AC	4.50±0.050	-0.39±0.16	4.0±1.0	60.0±20.0	CMOS output active "H"
	AD	4.35±0.050	-0.39±0.16	2.0±0.5	30.0±10.0	CMOS output active "H"
	AE	4.30±0.050	-0.39±0.16	4.0±1.0	60.0±20.0	CMOS output active "H"
	AF	4.45±0.050	-0.39±0.16	2.0±0.5	30.0±10.0	CMOS output active "H"
	AG	4.30±0.050	-0.39±0.16	2.0±0.5	30.0±10.0	CMOS output active "H"
	AH	4.40±0.050	-0.39±0.16	4.0±1.0	60.0±20.0	CMOS output active "H"

■ BLOCK DIAGRAM

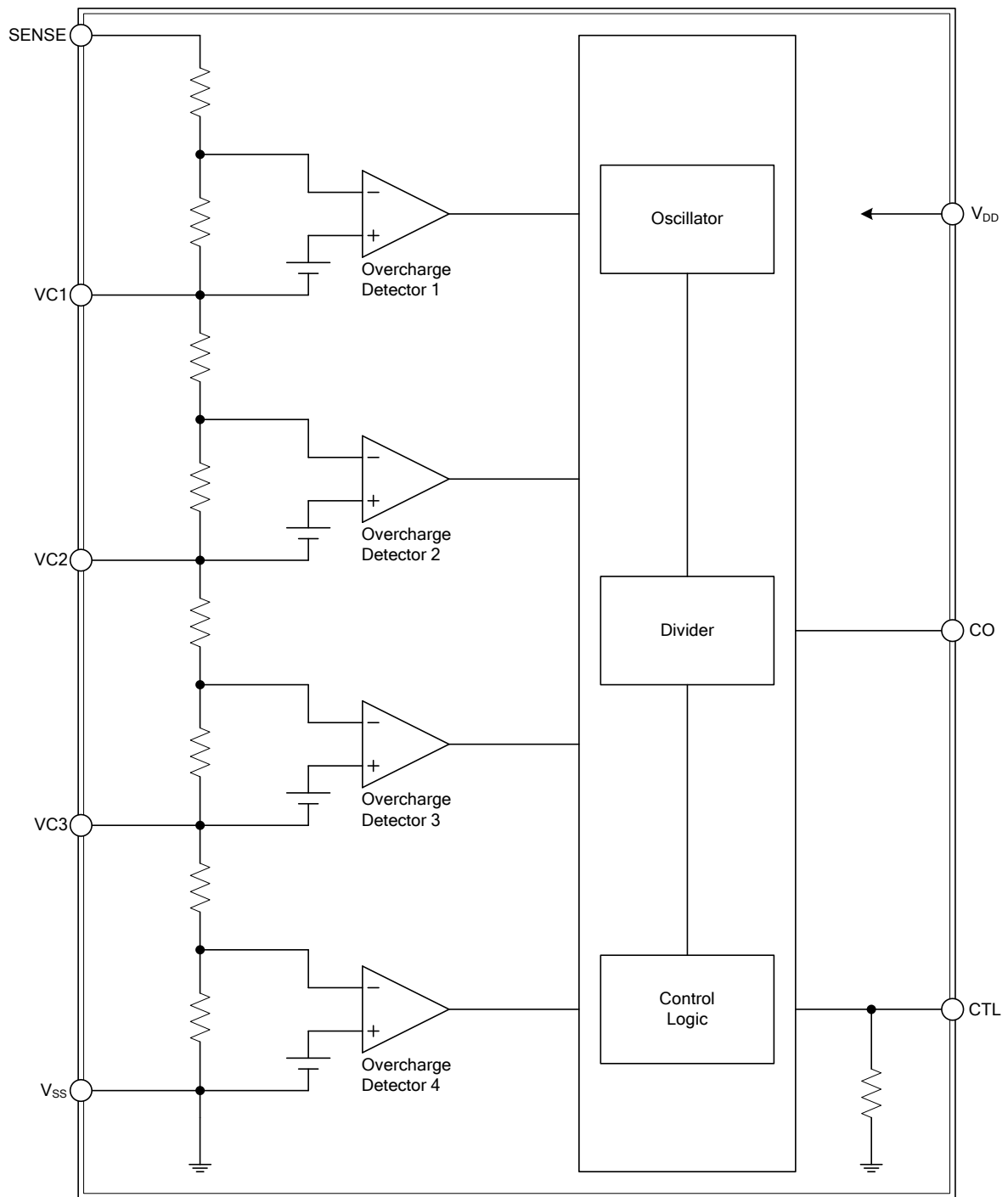

■ **ABSOLUTE MAXIMUM RATING** (T<sub>A</sub>=25°C, unless otherwise specified)

PARAMETER	SYMBOL	RATINGS	UNIT
Input Voltage Between V <sub>DD</sub> And V <sub>SS</sub>	V <sub>DS</sub>	V <sub>SS</sub> -0.3 ~ V <sub>SS</sub> +26	V
Input Pin Voltage	V <sub>IN</sub>	V <sub>SS</sub> -0.3 ~ V <sub>DD</sub> +0.3	V
CO Output Pin Voltage	V <sub>CO</sub>	V <sub>SS</sub> -0.3 ~ V <sub>DD</sub> +0.3	V
Power Dissipation (Note 2)	P <sub>D</sub>	650	mW
Operation Ambient Temperature	T <sub>OPR</sub>	-40 ~ +85	°C
Storage Temperature	T <sub>STG</sub>	-40 ~ +125	°C

- Notes: 1. Absolute maximum ratings are those values beyond which the device could be permanently damaged. Absolute maximum ratings are stress ratings only and functional device operation is not implied.  
2. When mounted on printed circuit board.

■ **ELECTRICAL CHARACTERISTICS** (T<sub>A</sub>=25°C, unless otherwise specified)

PARAMETER	SYMBOL	TEST CONDITIONS	MIN	TYP	MAX	UNIT
<b>DETECTION VOLTAGE</b>						
Overcharge Detection Voltage n (n=1, 2, 3, 4)	V <sub>CU<sub>n</sub></sub>	4.30 ~ 4.80 V, adjustable	V <sub>CU<sub>n</sub></sub> -0.050	V <sub>CU<sub>n</sub></sub>	V <sub>CU<sub>n</sub></sub> +0.050	V
Overcharge Hysteresis Voltage n (n=1, 2, 3, 4)	V <sub>HCU<sub>n</sub></sub>	V <sub>HCU<sub>n</sub></sub> =-0.52±0.21V, -0.39±0.16V, -0.26 ±0.11V, -0.13 ±0.06V, None		V <sub>HCU<sub>n</sub></sub>		V
<b>DELAY TIME</b>						
Overcharge Detection Delay Time	t <sub>CU</sub>		3.0	4.0	5.0	s
		For AD, AF and AG products	1.5	2.0	2.5	
Overcharge Release Delay Time	t <sub>CL</sub>		40	60	80	ms
		For AD, AF and AG products	20	30	40	
Overcharge Timer Reset Delay Time	t <sub>TR</sub>		10	15	20	ms
		For AD, AF and AG products	5	7.5	10	
Transition Time To Test Mode (Note 1)	t <sub>TST</sub>		40	60	80	ms
		For AD, AF and AG products	20	30	40	
CTL Pin Response Time	t <sub>CTL</sub>				3.0	ms
<b>INPUT VOLTAGE</b>						
Operating Voltage Between V <sub>DD</sub> And V <sub>SS</sub>	V <sub>DSOP</sub>		3.6		24	V
CTL Input "H" Voltage	V <sub>CTLH</sub>		V <sub>DD</sub> ×0.95			V
CTL Input "L" Voltage	V <sub>CTL</sub>				V <sub>DD</sub> ×0.4	V
<b>INPUT CURRENT</b>						
Current Consumption During Operation	I <sub>OP</sub>	V1=V2=V3=V4=3.5V		2.5	10	μA
Current Consumption During Overdischarge	I <sub>OPED</sub>	V1=V2=V3=V4=2.3V		2.0	10	μA
SENSE Pin Current	I <sub>SENSE</sub>	V1=V2=V3=V4=3.5V		1.5	6.0	μA
VC1 Pin Current	I <sub>VC1</sub>	V1=V2=V3=V4=3.5V	-0.5	0	0.5	μA
VC2 Pin Current	I <sub>VC2</sub>	V1=V2=V3=V4=3.5V	-0.5	0	0.5	μA
VC3 Pin Current	I <sub>VC3</sub>	V1=V2=V3=V4=3.5V	-0.5	0	0.5	μA
CTL Pin "H" Current	I <sub>CTLH</sub>	V1=V2=V3=V4=3.5 V, V <sub>CTL</sub> =V <sub>DD</sub>	1.0	1.5	2.0	μA
CTL Pin "L" Current	I <sub>CTL</sub>	V1=V2=V3=V4=3.5 V, V <sub>CTL</sub> =0 V	-0.1			μA
<b>OUTPUT CURRENT</b>						
CO Pin Sink Current	I <sub>COL</sub>	V <sub>COP</sub> =V <sub>SS</sub> +0.5V	0.4			mA
CO Pin Source Current	I <sub>COH</sub>	V <sub>COP</sub> =V <sub>DD</sub> -0.5V	20			μA

Note: 1. Test conditions: V1=V2=V3=V4=3.5V, V<sub>DD</sub> ≥ V<sub>SENSE</sub>+8.5V.

■ OPERATING

1. Overcharge Detection

Under normal conditions, when the voltage of any one cell battery exceeds the overcharge detection voltage ( $V_{CU}$ ) during charging, and after the state is retained for the overcharge detection delay time ( $t_{CU}$ ), CO will become “H”. This state is called overcharge. Attaching FET to the CO pin provides charge control and a second protection.

Only the voltages of all the batteries decreases below the total of the overcharge detection voltage ( $V_{CU}$ ) and the overcharge hysteresis voltage ( $V_{HC}$ ), and the state is retained for the overcharge release delay time ( $t_{CL}$ ) or longer, CO will become “L”.

2. Overcharge Timer Reset

When an overcharge release noise that forces the voltage of the battery temporarily below the overcharge detection voltage ( $V_{CU}$ ) is input during the overcharge detection delay time ( $t_{CU}$ ) from when  $V_{CU}$  is exceeded to when charging is stopped,  $t_{CU}$  is continuously counted if the time the overcharge release noise persists is shorter than the overcharge timer reset delay time ( $t_{TR}$ ). Under the same conditions, if the time the overcharge release noise persists is  $t_{TR}$  or longer, counting of  $t_{CU}$  is reset once. After that, when  $V_{CU}$  has been exceeded, counting  $t_{CU}$  resumes.

3. CTL Pin

The CTL pin is used to control the output voltage of the CO pin. In the UTC UB264A Series, the CTL pin takes precedence over the overcharge detection circuit.

CTL PIN	CO PIN
“H”	Normal state (Note 1)
Open	“H”
“L”	“H”
“L” → “H”	-
“H” → “L”	-

Note: 1. The state is controlled by the overcharge detection circuit.

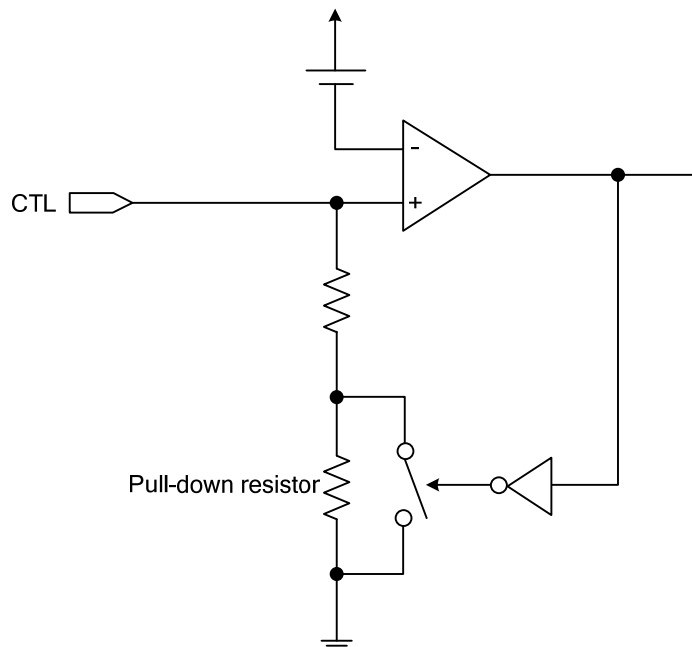

- Notes:
1. The reverse voltage “H” to “L” or “L” to “H” of CTL pin is  $V_{DD}$  pin voltage  $-2.8V$  (Typ.), does not have the hysteresis.
  2. Since the CTL pin implements high resistance of  $8M\Omega$  to  $12M\Omega$  for pull down, be careful of external noise application. If an external noise is applied, CO may become “H”. Perform thorough evaluation using the actual application.

■ OPERATING(Cont.)

4. Test Mode

In the UTC UB264A Series, the overcharge detection delay time ( $t_{CU}$ ) can be shortened by entering the test mode. The test mode can be set by retaining the  $V_{DD}$  pin voltage 8.5 V or more higher than the SENSE pin voltage for at least 80ms ( $V_1=V_2=V_3=V_4=3.5V$ ,  $T_a=25^\circ C$ ). The status is retained by the internal latch and the test mode is retained even if the  $V_{DD}$  pin voltage is decreased to the same voltage as that of the SENSE pin. When CO becomes "H" when the delay time has elapsed after overcharge detection, the latch for retaining the test mode is reset and the UTC UB264A Series exits from the test mode.

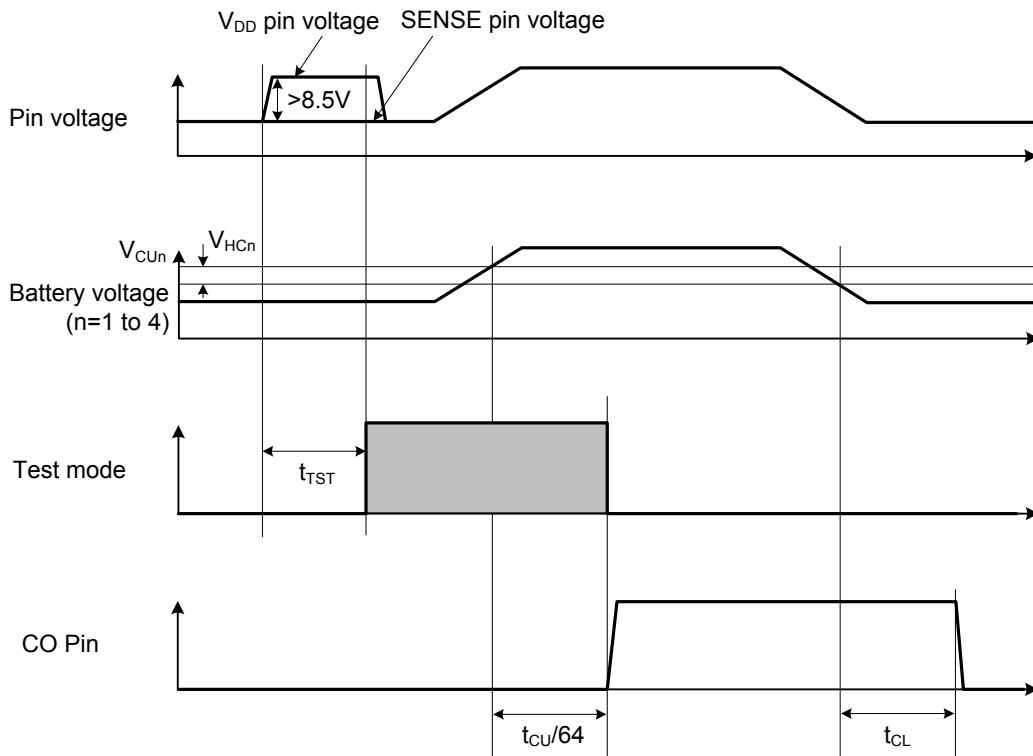

- Notes:
1. When the  $V_{DD}$  pin voltage is decreased to lower than the UVLO voltage of 2 V (Typ.), the UTC UB264A Series returns to the normal mode.
  2. Set the test mode when no batteries are overcharged.
  3. The overcharge release delay time ( $t_{CL}$ ) is not shortened in the test mode.
  4. The overcharge timer reset delay time ( $t_{TR}$ ) is not shortened in the test mode.

■ TIMING CHARTS

1. Overcharge Detection Operation

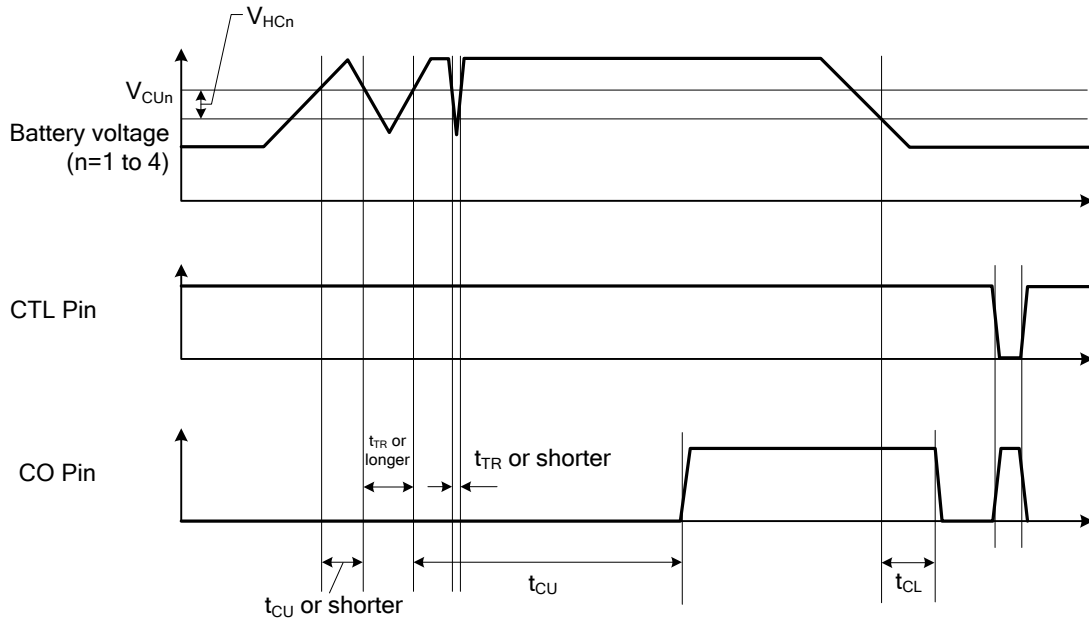

2. Overcharge Timer Reset Operation

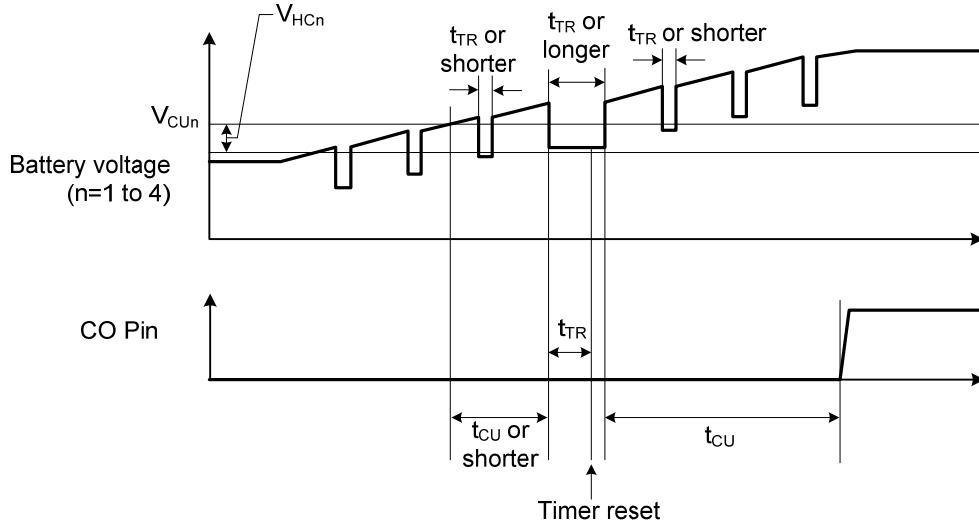

■ TYPICAL APPLICATION CIRCUIT

(1) 4-serial cell

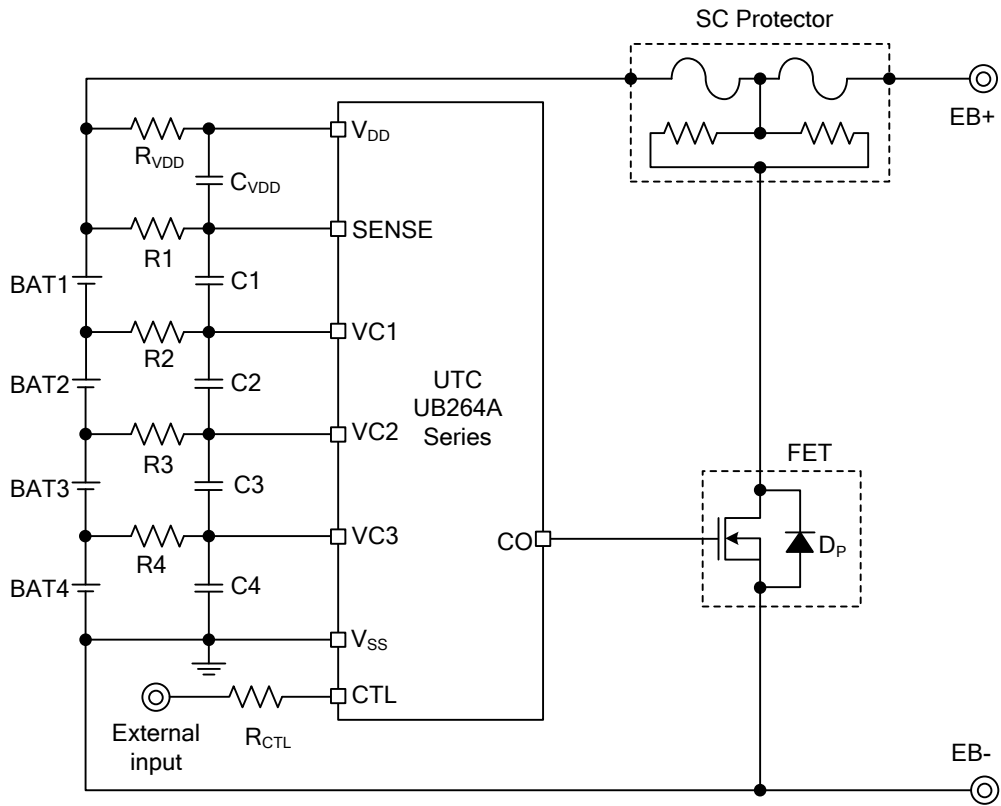

(2) 3-serial cell

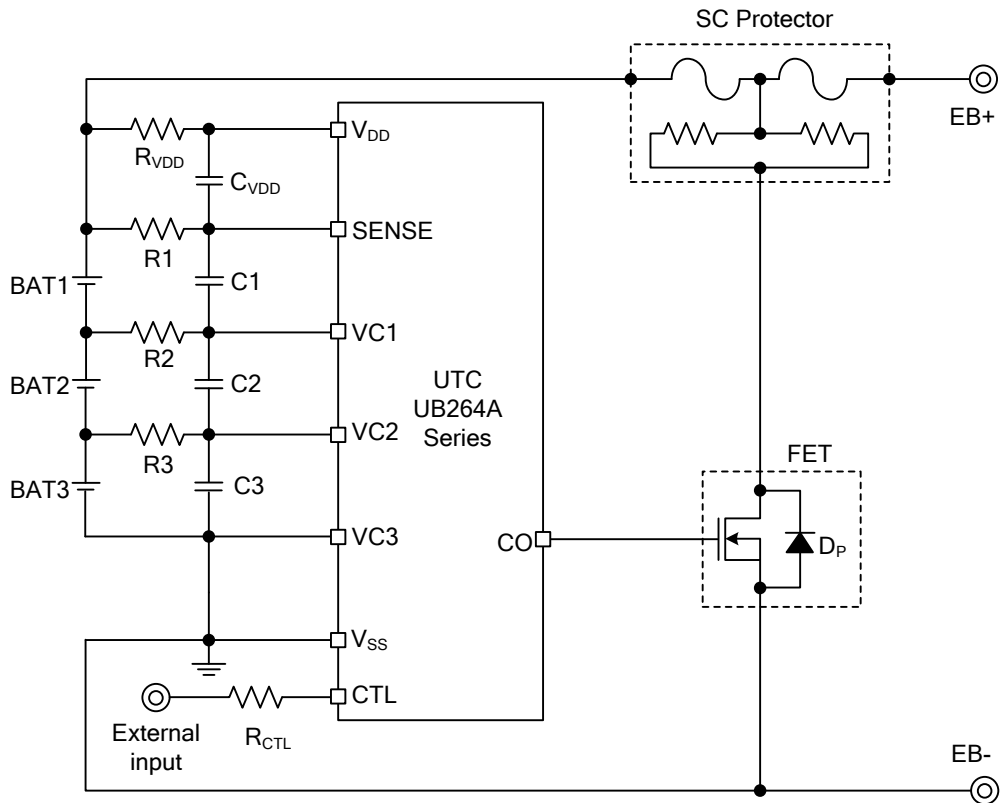

(3) 2-serial cell

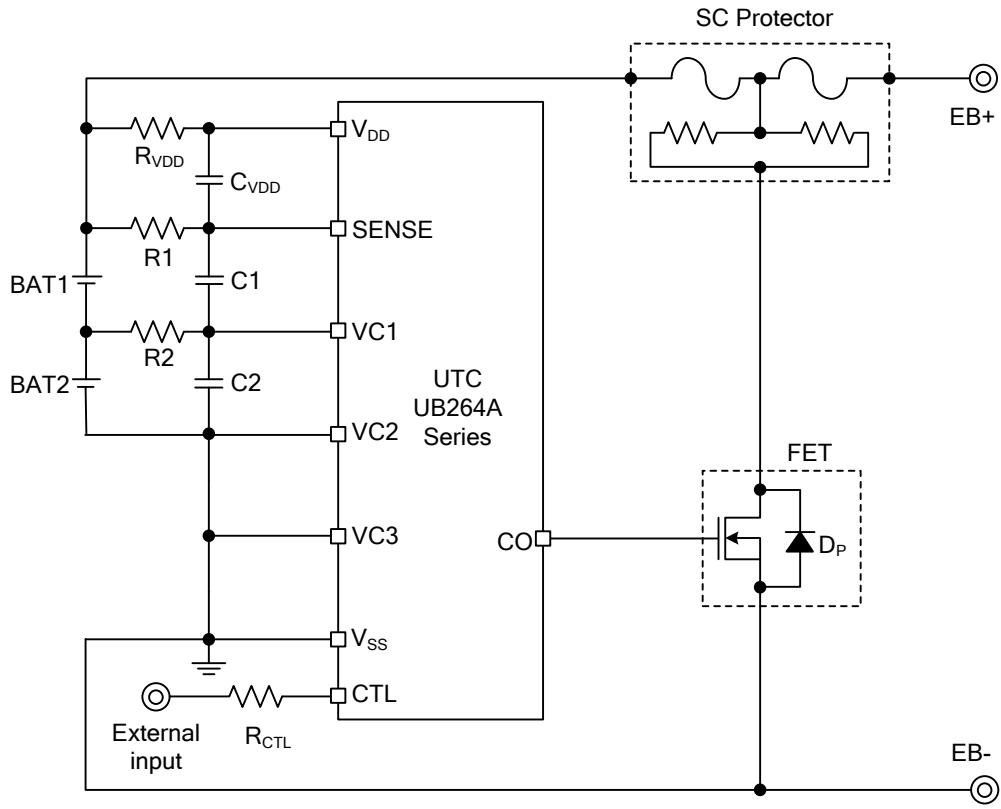

Constants for External Components

NO.	PART	MIN	TYP	MAX	UNIT
1	R1 to R4	0.1	1	10	kΩ
2	C1 to C4, C_VDD	0.01	0.1	1	μF
3	R_VDD	50	100	500	Ω
4	R_CTL	0	100	500	Ω

- Notes:
1. the examples of connection shown above and the constants will not guarantee successful operation. Perform thorough evaluation using the actual application to set the constant.
  2. Set the same constants to R1 to R4 and to C1 to C4 and C\_VDD.
  3. Set R\_VDD, C1 to C4 and C\_VDD so that the condition  $(R_{VDD}) \times (C1 \text{ to } C4, C_{VDD}) \geq 5 \times 10^{-6}$  is satisfied.
  4. T Set R1 to R4, C1 to C4, and C\_VDD so that the condition  $(R1 \text{ to } R4) \times (C1 \text{ to } C4, C_{VDD}) \geq 1 \times 10^{-4}$  is satisfied.
  5. In some application circuits, even if an overcharged battery is not included, the order of connecting batteries may be restricted to prevent transient output of CO detection pulses when the batteries are connected. Perform thorough evaluation with the actual application circuit.
  6. Since "H" may be output at CO transiently when the battery is being connected, connect the positive terminal of BAT1 last in order to prevent the three terminal protection fuse from cutoff.
  7. Before the battery connection, short-circuit the battery side pins R\_VDD and R1.
  8. In the UTC UB264A Series, normally input "H" to the external input, and input "L" when setting CO to "H".

■ TYPICAL APPLICATION CIRCUIT(Cont.)

(4) 4-serial cell (Overheat Protection via PTC)

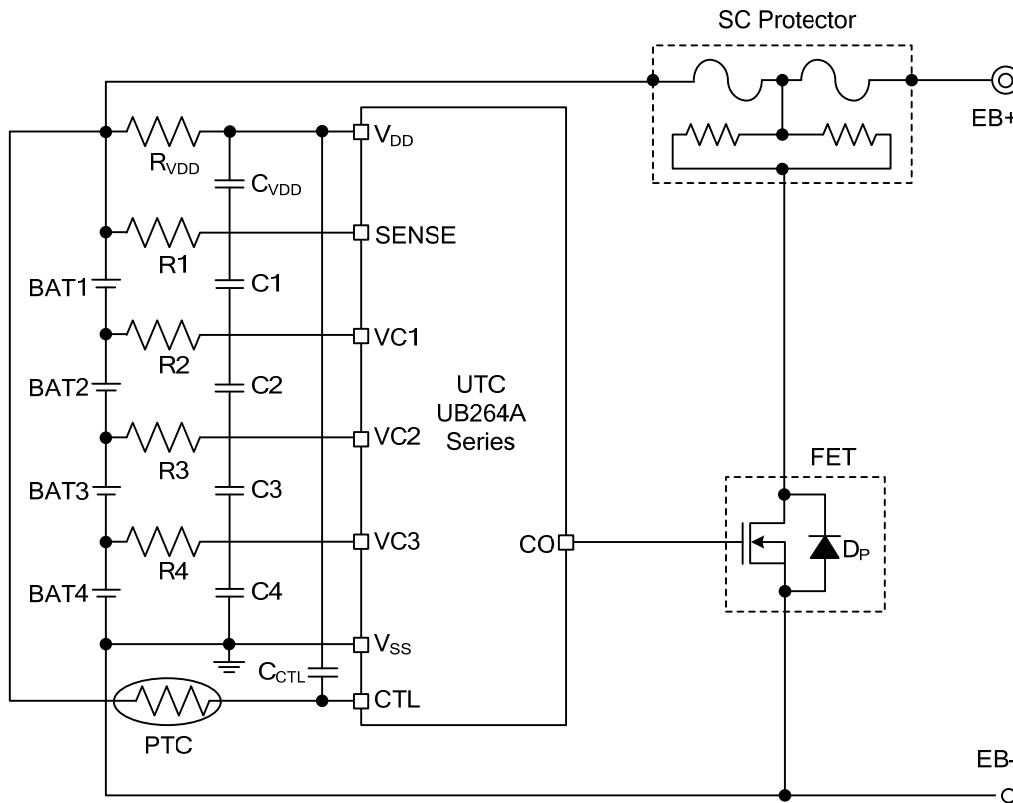

- Notes:
1. The above connection example will not guarantee successful operation. Perform thorough evaluation using the actual application.
  2. A pull-down resistor is included in the CTL pin. To perform overheat protection via the PTC in the UTC UB264A Series, connect the PTC before connecting batteries.
  3. When the power fluctuation is large, connect the power supply of the PTC to the V<sub>DD</sub> pin of the UTC UB264A Series.
  4. Since “H” may be output at CO transiently when the battery is being connected, connect the positive terminal of BAT1 last in order to prevent the three terminal protection fuse from cutoff.

UTC assumes no responsibility for equipment failures that result from using products at values that exceed, even momentarily, rated values (such as maximum ratings, operating condition ranges, or other parameters) listed in products specifications of any and all UTC products described or contained herein. UTC products are not designed for use in life support appliances, devices or systems where malfunction of these products can be reasonably expected to result in personal injury. Reproduction in whole or in part is prohibited without the prior written consent of the copyright owner. The information presented in this document does not form part of any quotation or contract, is believed to be accurate and reliable and may be changed without notice.