



UU4793

Preliminary

LINEAR INTEGRATED CIRCUIT

OVERLOAD MONITORING WITH RESISTIVE LOAD, $V_T = 44.5 \text{ mV}$

DESCRIPTION

The UTC **UU4793** is a bipolar integrated circuit designed for monitoring over loading or short circuit in automotive or industrial applications. The threshold V_T is 44.5 mV and $V_{4,6} = V_S - V_T$. V_T is not dependent of the power supply voltage V_S . If the voltage developed across shunt resistor R_{SH} exceeds V_T , IC turns on the output, or else turns off the output.

The output is turned off when input switch Pin 8 is open or there is a lack of power supply voltage. The output breakdown voltage is decided by the Z-diodes Z_3 and Z_5 which have a typical value of $V_Z = 22 \text{ V}$.

A not used of the comparator input have to be connected to Pin 7.

FEATURES

- * Two common reference comparators
- * Tight threshold tolerance
- * Constant threshold
- * Output with NPN
- * 8 kV - ESD protection
- * Protection of reverse polarity
- * Load-dump protection

ORDERING INFORMATION

Ordering Number		Package	Packing
Lead Free	Halogen Free		
UU4793L-S08-R	UU4793G-S08-R	SOP-8	Tape Reel
UU4793L-S08-T	UU4793G-S08-T	SOP-8	Tube

UU4793G-xx-S08-R 	(1) R: Tape Reel, T: Tube (2) S08: SOP-8 (3) xx: Refer to Marking Information (4) G: Halogen Free, L: Lead Free
----------------------	--

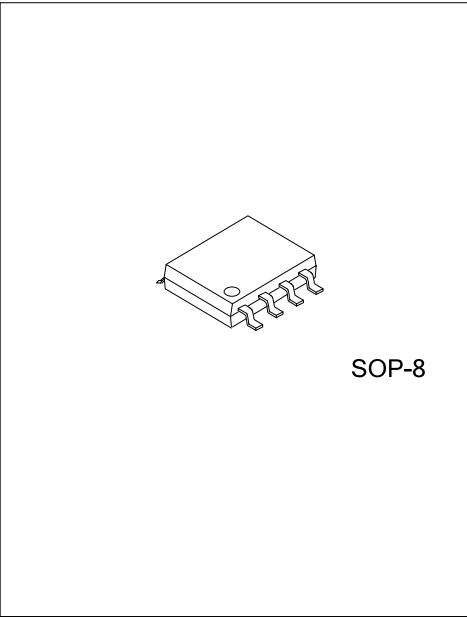

■ PIN CONFIGURATION

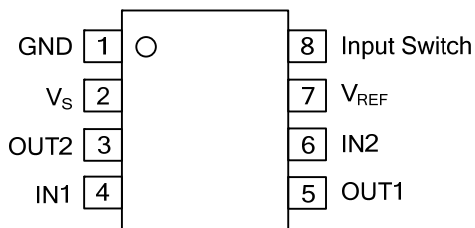

■ PIN DESCRIPTION

PIN NO.	PIN NAME	DESCRIPTION
1	GND	Ground
2	V_s	Power supply voltage
3	OUT2	Comparator 2 output
4	IN1	Comparator 1 input
5	OUT1	Comparator 1 output
6	IN2	Comparator 2 input
7	V_{REF}	Reference voltage
8	Input Switch	Input switch pin

■ BLOCK DIAGRAM

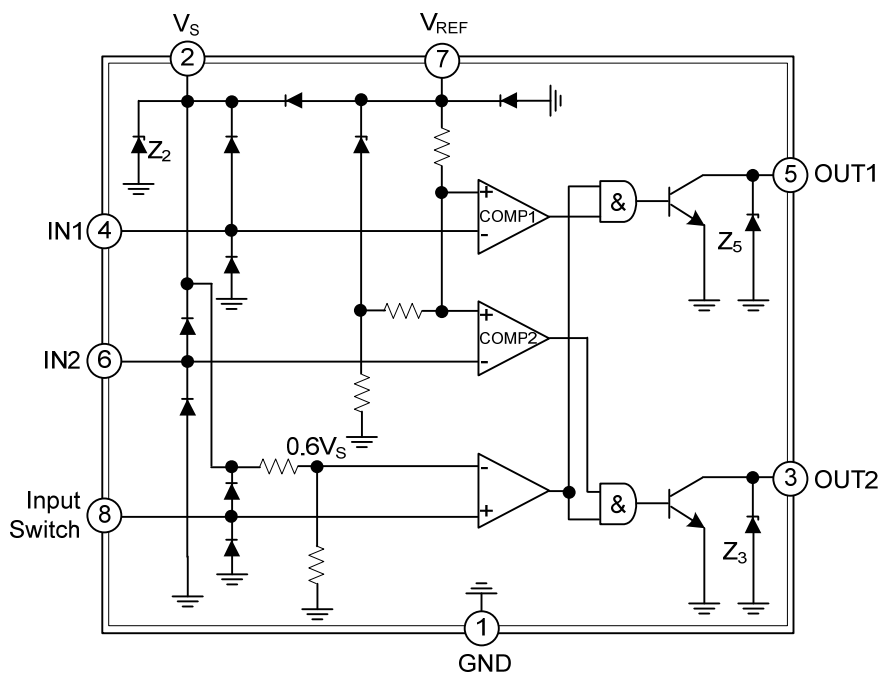

■ ABSOLUTE MAXIMUM RATING

PARAMETER		SYMBOL	RATINGS	UNIT
Supply Voltage	Pin 2, 7	V_S	16.5	V
Current Consumption ($t = 2\text{ms}$, measured at Pin 1 (GND))	Pin 1	I_1	1.5	A
Output Current	Pin 3, 5	$I_{3,5}$	20	mA
Input Voltage (reference point Pin 7)	Pin 4, 6	$-V_{4,6}$	6	V
Power Dissipation	$T_A = 95^\circ\text{C}$	P_D	360	mW
	$T_A = 60^\circ\text{C}$		560	
Ambient Temperature		T_A	-40 ~ +95	$^\circ\text{C}$
Junction Temperature		T_J	150	$^\circ\text{C}$
Storage Temperature		T_{STG}	-55 ~ +125	$^\circ\text{C}$

Note: Absolute maximum ratings are those values beyond which the device could be permanently damaged. Absolute maximum ratings are stress ratings only and functional device operation is not implied.

■ THERMAL DATA

PARAMETER	SYMBOL	RATINGS	UNIT
Junction to Ambient	θ_{JA}	160	K/W

■ ELECTRICAL CHARACTERISTICS ($V_S = 9\sim 15\text{ V}$, $T_A = -40\sim +95^\circ\text{C}$, fig. 1, unless otherwise specified)

PARAMETER	SYMBOL	TEST CONDITIONS	PIN	MIN	TYP	MAX	UNIT
Supply Voltage	V_S		2, 7	9		15	V
Internal Z-Diode Z_2	V_Z		2	20			V
Current Consumption	I_1	$V_S = 12\text{V}$ measured at Pin 1 (GND)	1		4.5	6	mA
Output Saturation Voltage	V_{SAT}	$V_S = 9\text{V}$, $I_{3,5} = 10\text{mA}$, $T_A = 25^\circ\text{C}$	3, 5			0.5	V
Output Z-Diodes Z_3, Z_5	V_Z		3, 5	21			V
Control Signal Threshold	$-V_T$	$I_{3,5} = 1\text{mA}$, $T_A = 25^\circ\text{C}$	4, 6	43	44.5	46	mV
Temperature Coefficient of Control Signal Threshold	T_C				15		$\mu\text{V/K}$
Threshold Voltage	V_8	Switch identification	8		$0.6 V_S$		V
Input Currents	I_i		4, 6		100		nA
			8		5		μA
Delay Time	$t_{D(ON)}$	Switch-on High to low	3, 5		6		μs
	$t_{D(OFF)}$	Switch-off Low to high			30		μs

■ TYPICAL APPLICATION CIRCUIT

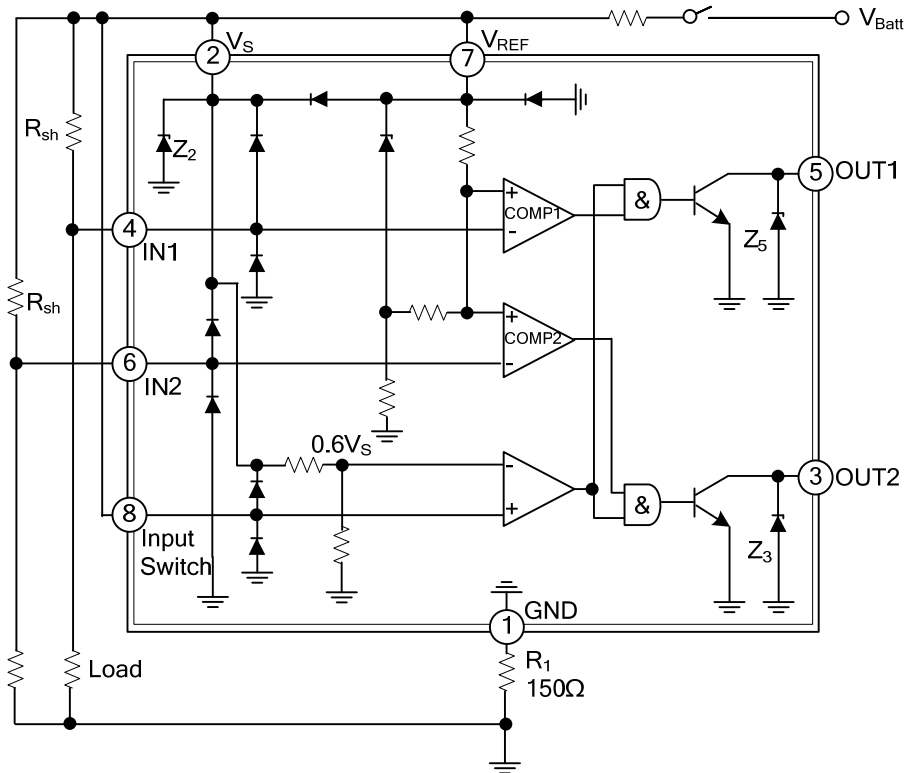

Fig. 1 Schematic and Application circuit

■ TIMING DIAGRAM

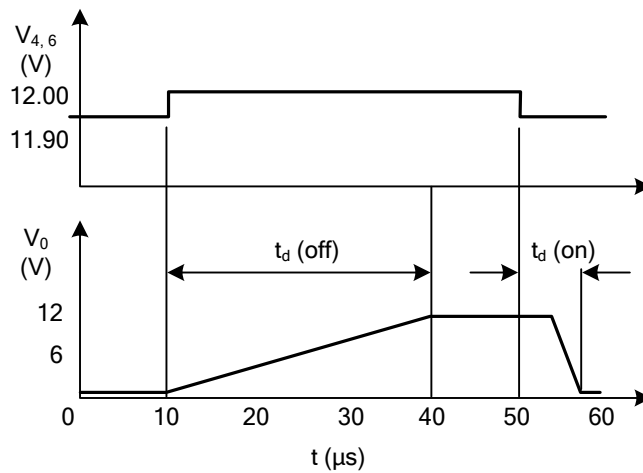

Fig. 2 Timing Diagram

UTC assumes no responsibility for equipment failures that result from using products at values that exceed, even momentarily, rated values (such as maximum ratings, operating condition ranges, or other parameters) listed in products specifications of any and all UTC products described or contained herein. UTC products are not designed for use in life support appliances, devices or systems where malfunction of these products can be reasonably expected to result in personal injury. Reproduction in whole or in part is prohibited without the prior written consent of the copyright owner. The information presented in this document does not form part of any quotation or contract, is believed to be accurate and reliable and may be changed without notice.