



# UC34463

## LINEAR INTEGRATED CIRCUIT

### 200KHZ, 2A PWM BUCK SWITCHING REGULATOR

#### DESCRIPTION

UTC **UC34463** is a PWM control, step down DC to DC power supply, fixed out 5V, with CA/CV mode and output line voltage loss compensation function. External EN port can control shutdown of the IC.

IC internal integration of various protection function, such as SCP, OTP, OCP and so on. The highest working voltage is up to 40V. The built-in compensation simplifies the peripheral applications.

The packages are available in a standard 8-lead SOP8.

#### FEATURES

- \* Voltage mode non-synchronous PWM control
- \* Thermal-shutdown and current-limit protection
- \* ON/OFF shutdown control input
- \* Input voltage range up to 40V
- \* Output load current: 2A
- \* 200 kHz fixed frequency internal oscillator
- \* Low power standby mode
- \* Built-in switching transistor on chip

#### ORDERING INFORMATION

Ordering Number		Package	Packing
Lead Free	Halogen Free		
UC34463L-S08-R	UC34463G-S08-R	SOP-8	Tape Reel
UC34463L-S08-T	UC34463G-S08-T	SOP-8	Tube
UC34463L-SH2-R	UC34463G-SH2-R	HSOP-8	Tape Reel
UC34463L-SH2-T	UC34463G-SH2-T	HSOP-8	Tube

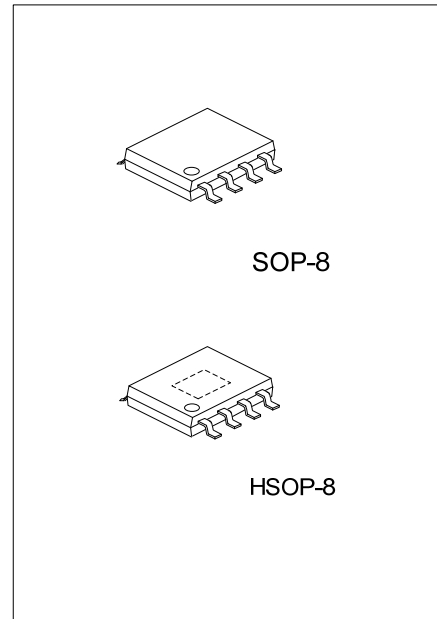

<p>UC34463L-S08-R</p> <p>(1) Packing Type</p> <p>(2) Package Type</p> <p>(3) Lead Free</p>	<p>(1) R: Tape Reel, T: Tube</p> <p>(2) S08: SOP-8, SH2: HSOP-8</p> <p>(3) Halogen Free, L: Lead Free</p>
--	---

## PIN CONFIGURATION

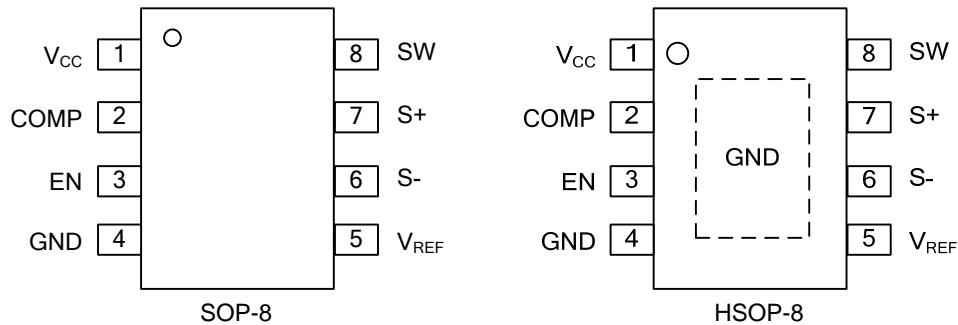

## PIN DESCRIPTION

PIN NO.	PIN NAME	DESCRIPTION
1	V <sub>CC</sub>	Operating voltage input
2	COMP	Compensation
3	EN	Shutdown pin
4	GND	Ground.
5	V <sub>REF</sub>	5V reference voltage
6	S-	Negative input
7	S+	Positive input
8	SW	Switching output

## BLOCK DIAGRAM

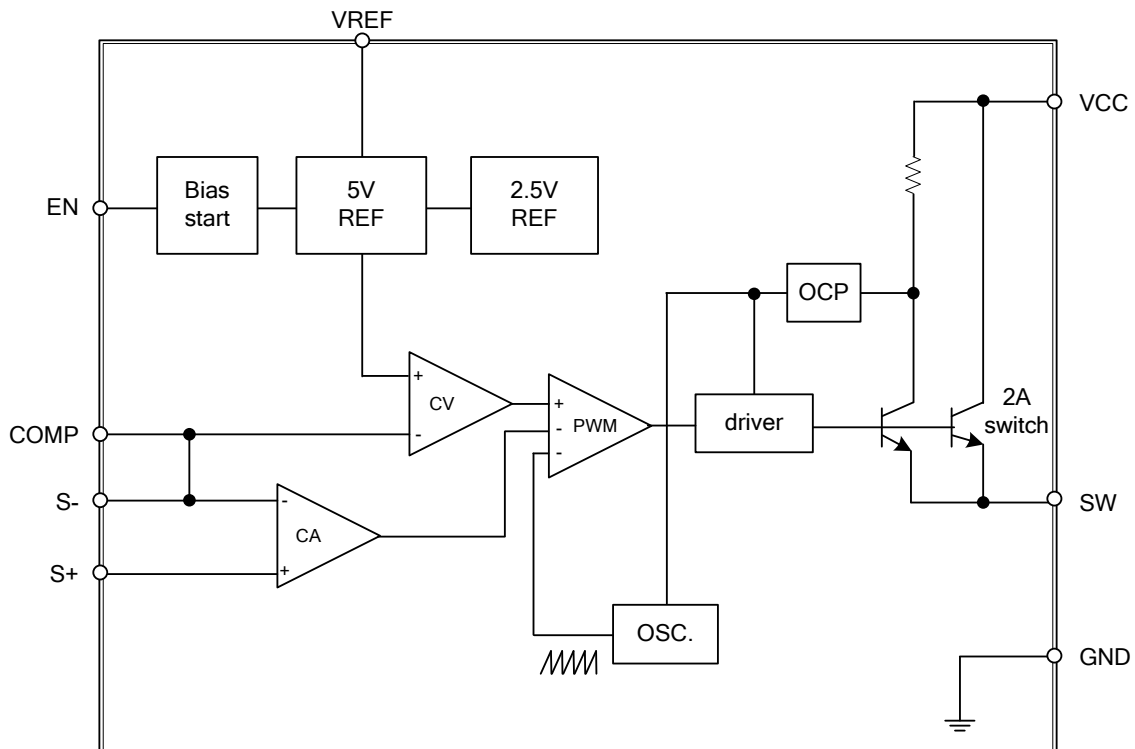

### ■ ABSOLUTE MAXIMUM RATING

PARAMETER	SYMBOL	RATINGS	UNIT
Supply Voltage	$V_{CC}$	+45	V
Power Dissipation	$P_D$	Internally limited	W
Storage Temperature	$T_{STG}$	-65 ~ +150	°C
Operating Temperature	$T_{OPR}$	-40 ~ +125	°C

Note: Absolute maximum ratings are those values beyond which the device could be permanently damaged. Absolute maximum ratings are stress ratings only and functional device operation is not implied.

### ■ ELECTRICAL CHARACTERISTICS ( $V_{IN}=12V$ , $I_{LOAD} = 0.2A$ , unless otherwise specified)

PARAMETER		SYMBOL	TEST CONDITIONS	MIN	TYP	MAX	UNIT
Oscillator Frequency		$F_{OSC}$		170	200	220	Khz
Oscillator Frequency of Short Circuit Protect		$F_{SCP}$	When current limit occurred and $V_{OUT}$ low		30		Khz
Saturation Voltage		$V_{SAT}$	$I_{OUT}=1.5A$ no outside circuit $V_{OUT}=0V$ force driver on		1.25 1.25	1.4 1.5	V
Max. Duty Cycle(ON)		DC	$V_{OUT}=0V$ force driver on		100		%
Min. Duty cycle(OFF)			$V_{OUT}=12V$ force driver off		0		
Current Limit		$I_{CL}$	peak current no outside circuit $V_{OUT}=0$ force driver on	2.4 2.4	2.9 2.9	3.3 3.6	A
Output Leakage Current	Output = 0V	$I_L$	no outside circuit $V_{OUT}=12V$ force driver off			-200	uA
	Output = -1V		$V_{IN}=24V$		-5		mA
Quiescent Current		$I_Q$	$V_{OUT}=12V$ force driver off		5	10	mA
Standby Quiescent Current		$I_{STBY}$	ON/OFF pin=5V, $V_{IN}=24V$		70 70	150 200	uA
ON/OFF Pin Logic Input Threshold Voltage		$V_{IL}$	Low (regulator ON)		1.3	0.6	V
		$V_{IH}$	High (regulator OFF)	2.0	1.3		
ON/OFF Pin Logic Input Current		$I_H$	$V_{LOGIC}=2.5V$ (OFF)			0.01	uA
ON/OFF Pin Input Current		$I_L$	$V_{LOGIC}=0.5V$ (ON)		-0.1	-1	
Over Temperature Shutdown Threshold		$T_S$	$T_J$ increasing		175		°C
			$T_J$ decreasing		150		

## ■ TYPICAL APPLICATION CIRCUIT

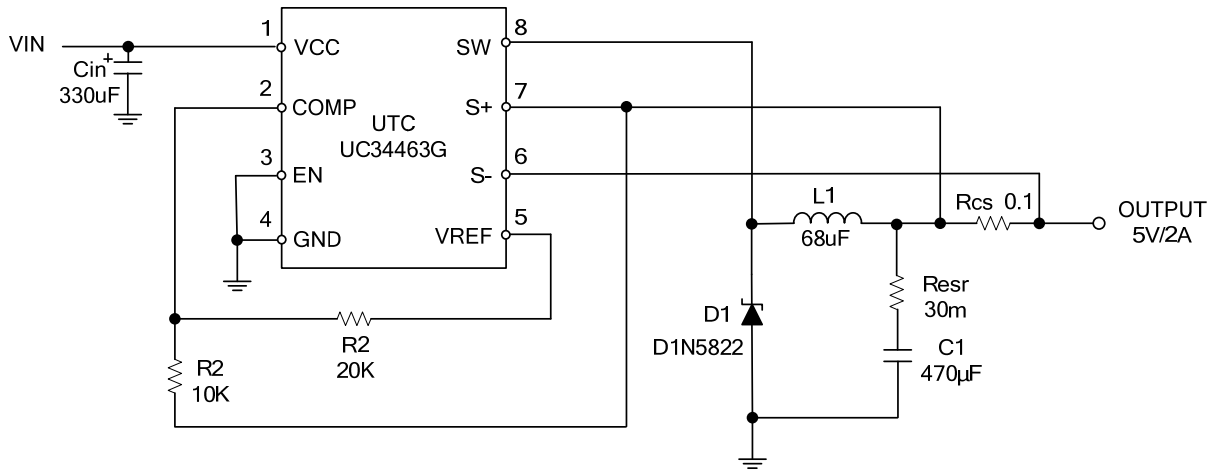

Note: If  $V_{CC} > 24V$ , COMP pin to GND need to add 0.1uF (option) compensation capacitor.

## ■ TYPICAL CHARACTERISTICS

1. Boot Power (CH2: Yellow 5V/div, CH3: Blue 2V/div)

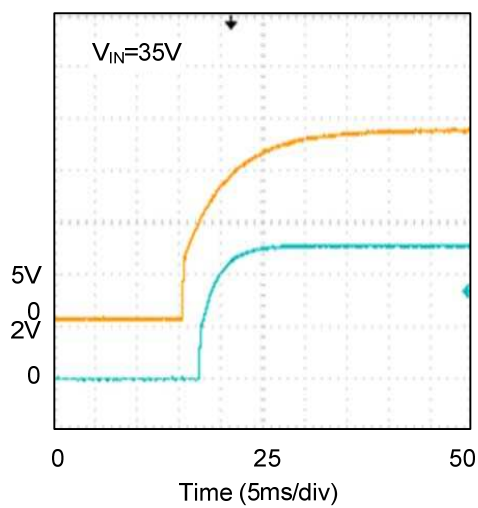
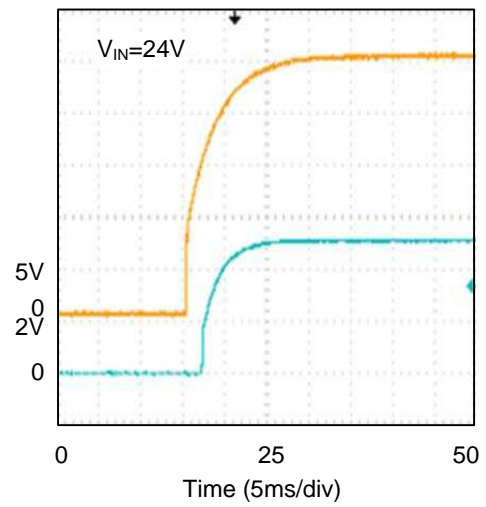
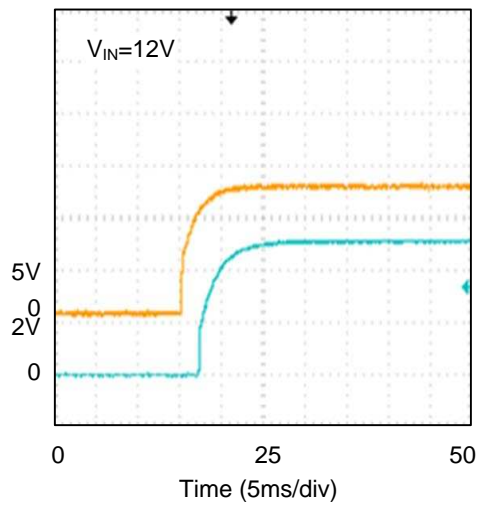

2. CA Mode

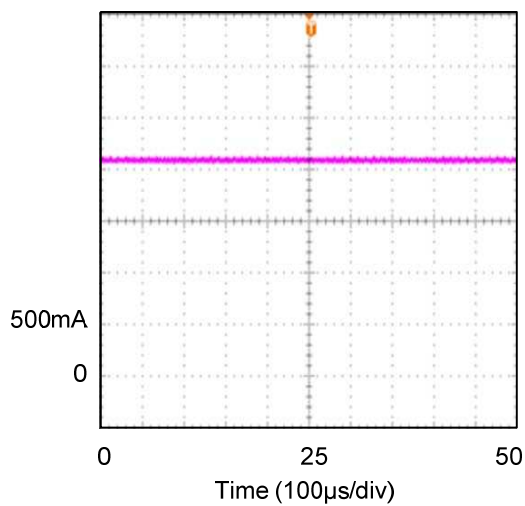

UTC assumes no responsibility for equipment failures that result from using products at values that exceed, even momentarily, rated values (such as maximum ratings, operating condition ranges, or other parameters) listed in products specifications of any and all UTC products described or contained herein. UTC products are not designed for use in life support appliances, devices or systems where malfunction of these products can be reasonably expected to result in personal injury. Reproduction in whole or in part is prohibited without the prior written consent of the copyright owner. The information presented in this document does not form part of any quotation or contract, is believed to be accurate and reliable and may be changed without notice.