



US16855

Preliminary

CMOS IC

DUAL HIGH-SIDE SWITCH FOR USB APPLICATION

DESCRIPTION

The UTC US16855 is a dual channel power switch with independent enable and flag functions optimized for bus-powered Universal Serial Bus (USB) and self-powered applications.

This product satisfies USB voltage drop requirement with soft start which eliminates the momentary voltage drop on the upstream port that may occur.

In addition, the UTC US16855 is equipped with over-temperature and over-current detectors and each flag output is available to indicate fault conditions independently to the USB controller. The UTC US16855 is available in active-high versions in 8-pin SOP package.

FEATURES

- \* 4V ~ 5.5V operating range
\* Two P-channel power MOSFET control switch
\* Over-current protection
\* Under-voltage lockout circuit
\* Thermal shutdown circuit
\* Soft-start circuit
\* Flag indicates fault conditions

ORDERING INFORMATION

Table with 4 columns: Ordering Number (Lead Free, Halogen Free), Package, and Packing. Rows include US16855L-S08-R, US16855G-S08-R, US16855L-S08-T, and US16855G-S08-T.

Note: xx: Output Voltage, refer to Marking Information.

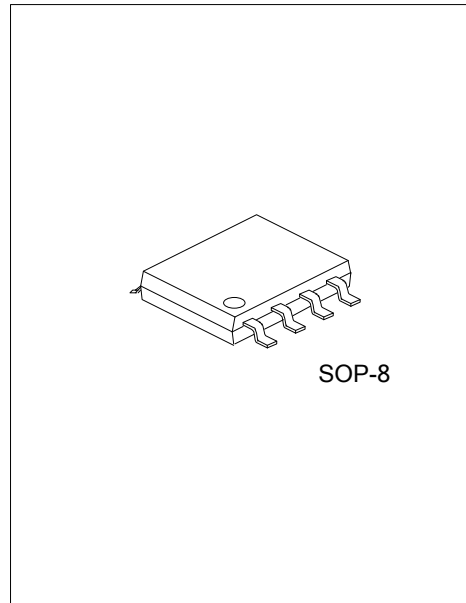
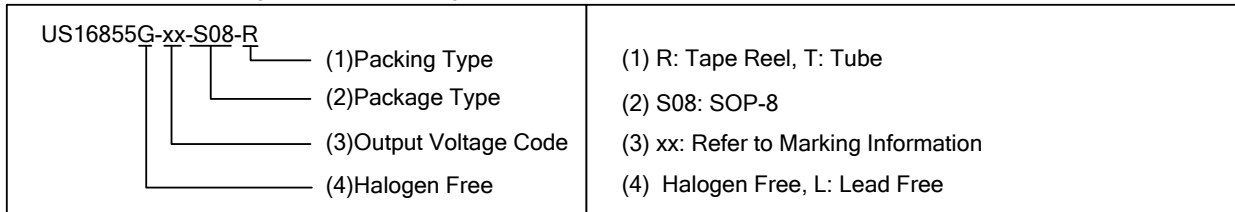

## ■ PIN CONFIGURATION

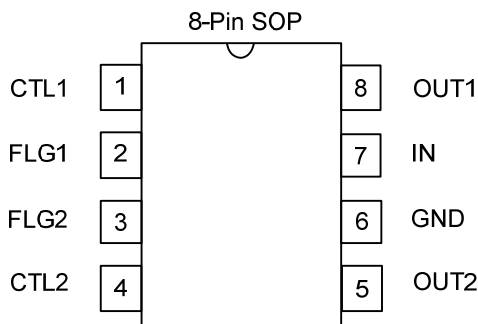

## ■ PIN DESCRIPTION

PIN NO.	PIN NAME	DESCRIPTION
1, 4	CTL1/CTL2	Control : TTL Input
2, 3	FLG1/FLG2	Over Current Detect Flag : Active-L, Nch open-drain
6	GND	Ground
7	IN	Power Supply : Source of MOSFET
8, 5	OUT1/OUT2	Output of Switch : Drain of MOSFET

## ■ DESCRIPTION of UTC US16855 FUNCTION

CTL Input Logic	Switch Operation with Over-Current Detect
"H" active	Switch Off regardless of CTL Input

## ■ TRUTH TABLE (H: High, L: Low, ON: Turn on, OFF: Turn off, X: H or L)

CTL1	FLG1	OUT1	CTL2	FLG2	OUT2	Operating mode
H	H	ON	H	H	ON	Normal mode
H	H	ON	L	H	OFF	Only OUT1 is ON
L	H	OFF	H	H	ON	Only OUT2 is ON
L	H	OFF	L	H	OFF	Standby mode
H	L	OFF	H	H	ON	Only OUT1 is over-current detect
H	H	ON	H	L	OFF	Only OUT2 is over-current detect
X	L	OFF	X	L	OFF	TSD mode
X	L	OFF	X	L	OFF	UVLO mode

■ BLOCK DIAGRAM

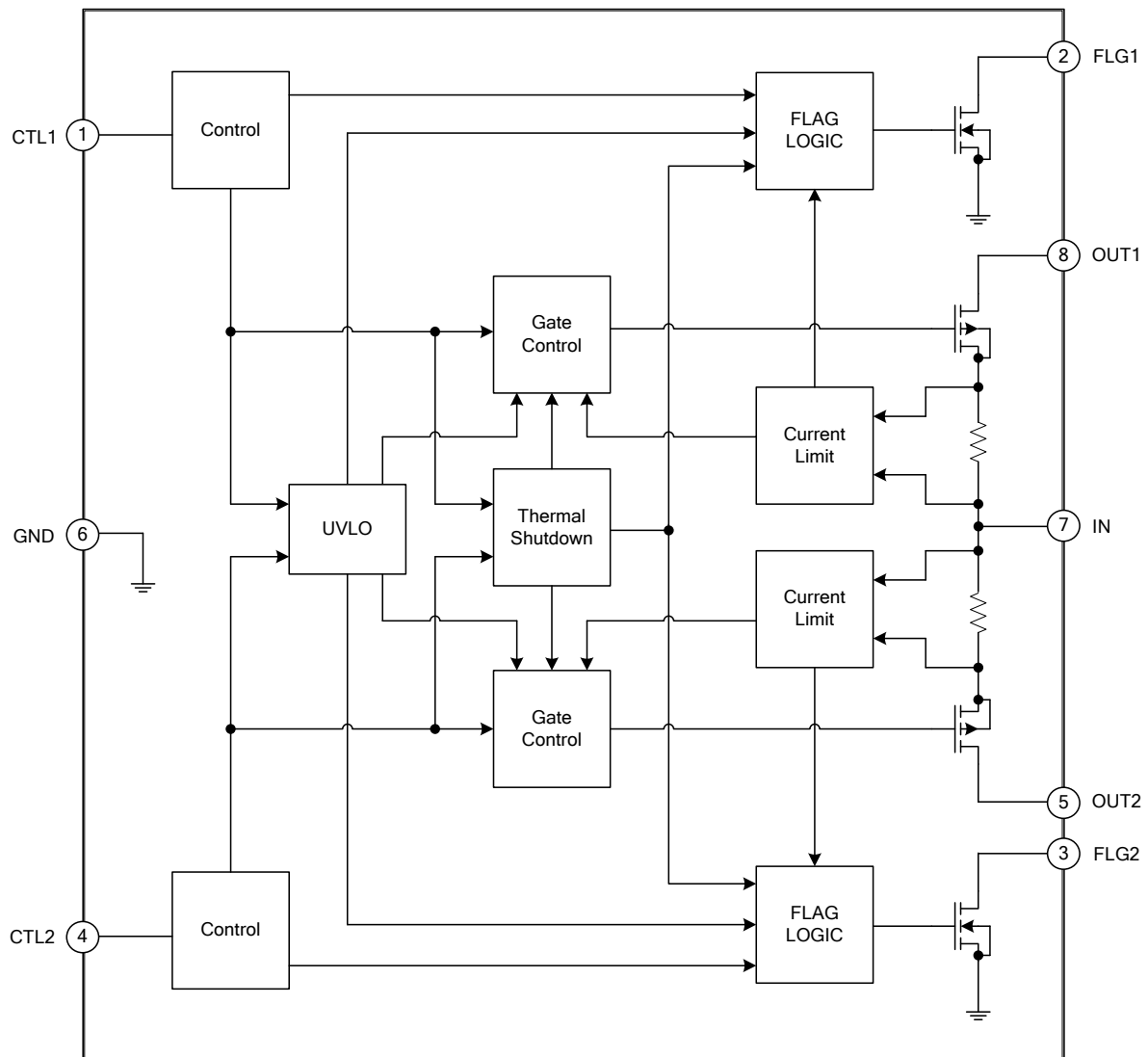

■ **ABSOLUTE MAXIMUM RATING** ( $T_A=25^{\circ}\text{C}$ , Unless otherwise specified)

PARAMETER		SYMBOL	RATINGS	UNIT
Input Voltage		$V_{IN}$	-0.3 ~ +6	V
Flag Voltage		$V_{FLG}$	-0.3 ~ +6	V
Control Input Voltage		$V_{CTL}$	-0.3 ~ +6	V
Output Voltage		$V_{OUT}$	$V_{IN} + 0.3$	V
Flag Current		$I_{FLG}$	50	mA
Output Current	DC	$I_{OUT}$	$V_{IN}=V_{CTL}=5\text{ V}$	+0.5
	Pulse Width $\leq 100\mu\text{s}$ Single Pulse		+3	-0.1
Power Dissipation		$P_D$	300	mW
Operating Temperature		$T_A$	-40 ~ +85	$^{\circ}\text{C}$
Storage Temperature		$T_{STG}$	-55 ~ +150	$^{\circ}\text{C}$

- Notes: 1. Absolute maximum ratings are those values beyond which the device could be permanently damaged. Absolute maximum ratings are stress ratings only and functional device operation is not implied.  
 2. The thermal shutdown circuit (operating temperature is more than 150  $^{\circ}\text{C}$  typ.) builds in this product.

■ **RECOMMENDED OPERATING RANGE**

PARAMETER	SYMBOL	RATINGS	UNIT
Input Voltage	$V_{IN}$	+4 ~ +5.5	V
Operating Temperature	$T_A$	0 ~ +70	$^{\circ}\text{C}$

■ **ELECTRICAL CHARACTERISTICS** ( $T_A = +25^{\circ}\text{C}$ ,  $V_{IN} = +5\text{V}$ , Unless otherwise specified)

PARAMETER	SYMBOL	TEST CONDITIONS	MIN	TYP	MAX	UNIT
<b>DC CHARACTERISTICS</b>						
Circuit Current	$I_{DD}$	$V_{CTL}=0\text{V}$ (both pin 1 & pin 4), OUT = open		1	5	$\mu\text{A}$
		$V_{CTL}=V_{IN}$ , OUT = open		1	1.5	mA
Low-level Input Voltage	$V_{IL}$	CTL Pin			1.0	V
High-level Input Voltage	$V_{IH}$	CTL Pin	2.0			V
Input Current of CTL pin	$I_{CTL}$	$V_{CTL}=0\text{V}$		0.01	1	$\mu\text{A}$
		$V_{CTL}=V_{IN}$		0.01	1	$\mu\text{A}$
Output MOSFET On Resistance	$R_{ON}$	$T_A=0 \sim +70^{\circ}\text{C}$ , $I_{OUT}=500\text{ mA}$		100	130	m $\Omega$
Output Leak Current	$I_{O\text{ LEAK}}$				10	$\mu\text{A}$
Over Current Detect Threshold	$I_{TH}$	$T_A=0 \sim +70^{\circ}\text{C}$	0.6	0.9	1.25	A
Flag Output Resistance	$R_{ONF}$	$I_L=10\text{ mA}$		10	25	$\Omega$
Flag Leak Current	$I_{O\text{ LEAK F}}$	$V_{FLAG}=5\text{ V}$		0.01	1	$\mu\text{A}$
Operating Voltage of Under Voltage Locked Out Circuit	$V_{UVLO}$	$V_{IN}$ : Up	2.2	2.5	2.8	V
		$V_{IN}$ : Down	2.0	2.3	2.6	V
		Hysteresis	0.1	0.2	0.3	V
<b>AC CHARACTERISTICS</b>						
Output Transition Rising Time	$t_{RISE}$	$R_L=10\Omega$ each output	2.5		12	ms
Output Transition Falling Time	$t_{FALL}$	$R_L=10\Omega$ each output			10	$\mu\text{s}$
Over Current Detect Delay Time	$t_{OVER}$		5		20	$\mu\text{s}$
CTL Input Low-Level Time	$t_{CTL}$	CTL : H $\rightarrow$ L $\rightarrow$ H	20			$\mu\text{s}$

■ TIMING DIAGRAM

Output Transition Rising Time (at ON)/Output Transition Falling Time (at OFF) at the timing of CTL changing “L” to “H”/“H” to “L” for UTC US16855

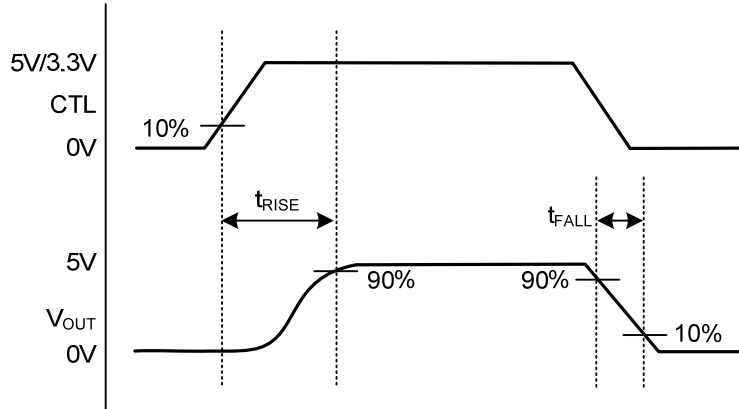

Over Current Detect Delay Time/CTL Input Low-Level Time for UTC US16855

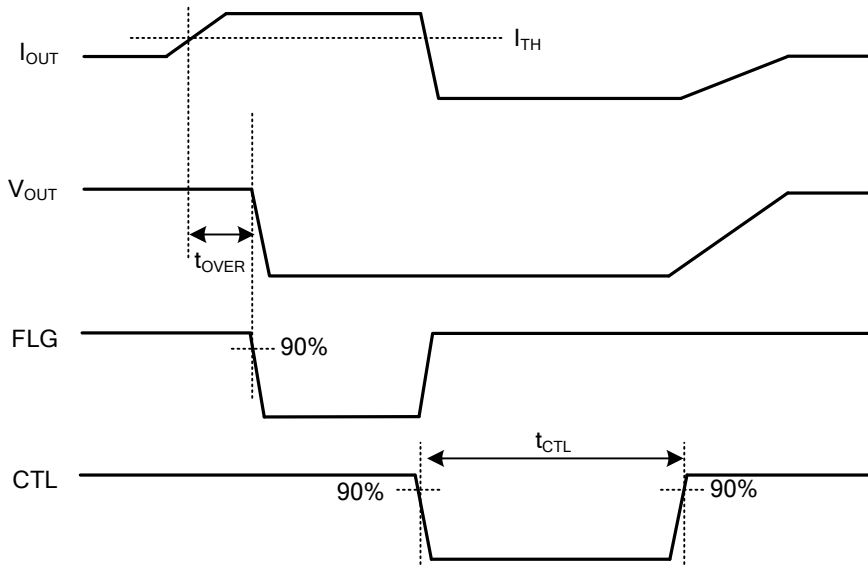

Over Current Detect Delay Time/CTL Input Low-Level Time for UTC US16855

■ FUNCTION DESCRIPTION

**UNDER VOLTAGE LOCKED OUT**

UVLO prevents malfunction of the switch because of voltage variation. When input voltage exceeds 2.5V (typical), the output MOSFET turns on. If input voltage drops below 2.3V (typical), UVLO shuts off the both output MOSFET switches and signals the FLAG.

**POWER ON AND OFF**

The UTC **US16855** performs a soft-start operation on power application, which is to prevent an over-current or inrush-current from flowing through the switch from IN to OUTX towards to the load, while the high-capacity capacitor is connected to the OUTX.

**OVER CURRENT DETECT**

The specification of over current detect is 0.6 ~ 1.25 A (typ. 900mA) in this IC. (500 mA max. in USB standard) This function is that flag-pin turns to Low-level and reports to the USB controller when over current is detected.

At this time, output of IC is operated as followed.

Output turns to off, and isn't based on the state of CTL-pin.

When CTL-pin turns to non-active, FLG-pin returns to High-level and Output-pin turn to OFF-state.

Immediately the controller should be inputted non-active level to CTL-pin after detecting FLG = "L" not to reach to the state of thermal shutdown.

Then, in the case of FLG-pin is High-level and CTL-pin is active level, Output-pin turns to ON-state.

To prevent from detecting wrongly the current to the moment, over current detect delay time is set up.

This delay time is 10 ms (typ.).

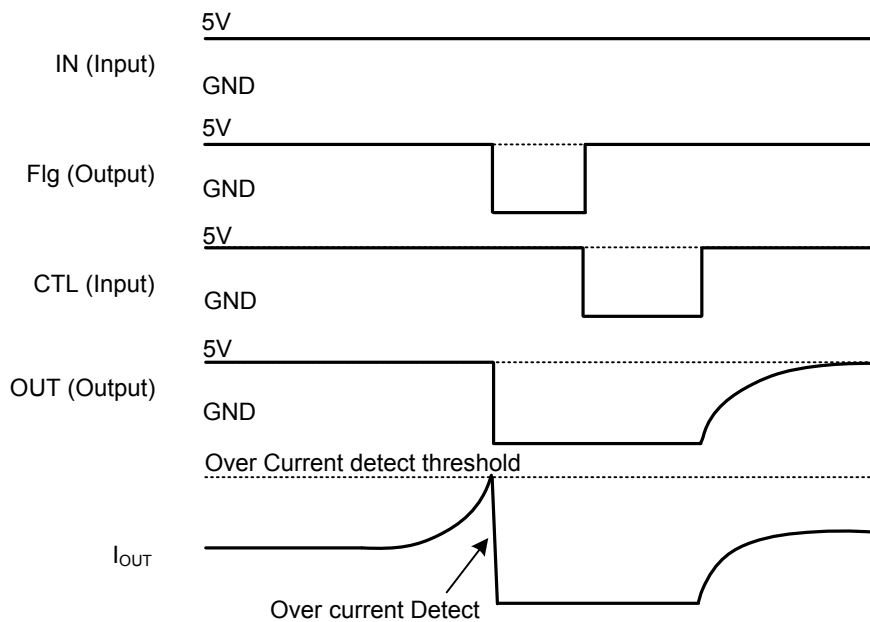

■ FUNCTION DESCRIPTION(Cont.)

**THERMAL SHUTDOWN**

The UTC **US16855** is internally protected against excessive power dissipation by thermal shutdown protection circuit. If device junction temperature rise above approximately 150°C, both switches are turned off, both fault FLAG outputs are activated, and they goes low. Hysteresis ensures that both switches turned off by thermal shutdown will not be turned on again until the die temperature is reduced to 145°C. When the thermal shutdown circuit is activated, the output pins are in the OFF status. However, the UTC **US16855** enters the standby status when CTL pins are all inactive.

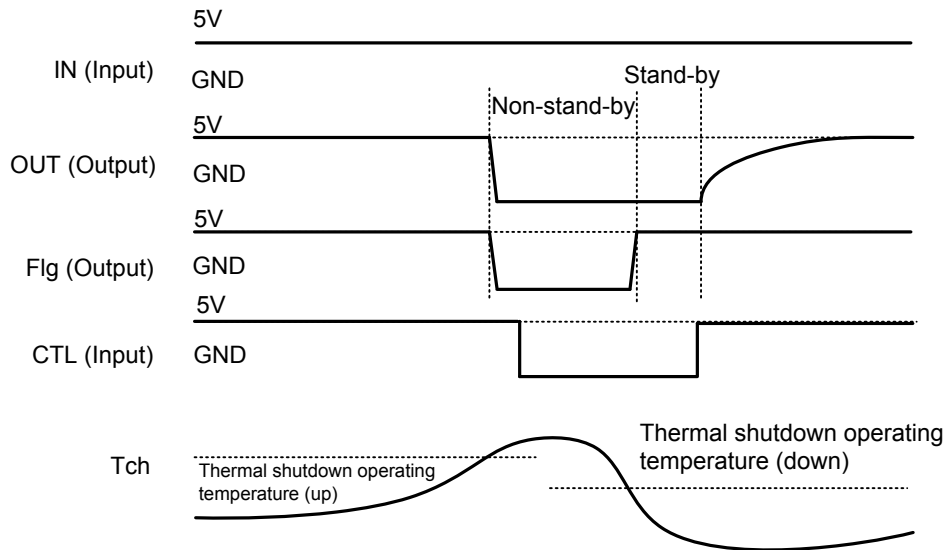

■ TEST CIRCUIT

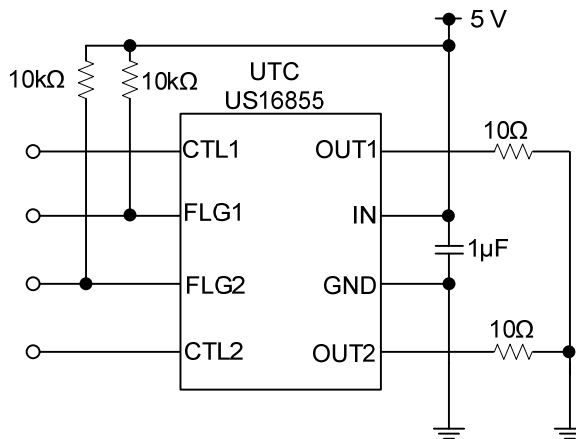

■ TYPICAL APPLICATION CIRCUIT

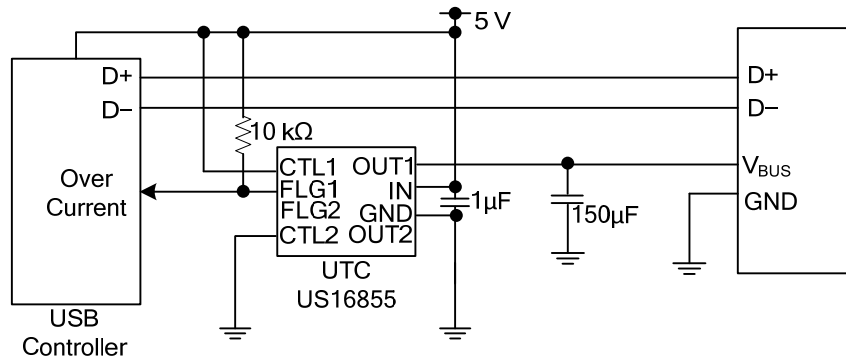

USB OUTPUT Port : 1 port  
controllable by USB-controller

UTC assumes no responsibility for equipment failures that result from using products at values that exceed, even momentarily, rated values (such as maximum ratings, operating condition ranges, or other parameters) listed in products specifications of any and all UTC products described or contained herein. UTC products are not designed for use in life support appliances, devices or systems where malfunction of these products can be reasonably expected to result in personal injury. Reproduction in whole or in part is prohibited without the prior written consent of the copyright owner. The information presented in this document does not form part of any quotation or contract, is believed to be accurate and reliable and may be changed without notice.