



# US2076B

Preliminary

CMOS IC

## DUAL USB HIGH-SIDE POWER SWITCH

### DESCRIPTION

The UTC **U2076B** is a dual integrated high-side power switch particularly designed for self-powered and bus-powered Universal Serial Bus (USB) applications.

The UTC **U2076B** meets the requirements of the USB. The low on-resistance of the switch satisfies USB voltage drop requirements. Fault current is limited to typically 750mA, well below the UL 25VA safety requirement. Flag outputs are available to indicate fault conditions to the local USB controller. In addition, soft start can eliminate the momentary voltage drop which is generated on the upstream port that may occur when the switch is enabled in bus-powered applications.

This device has independent functions enable and flag, and an enable input is compatible with both 3.3V and 5V logic.

The UTC **U2076B** includes protection circuits. Thermal shutdown circuit is designed to protect the device from being damaged when high-current loads exist. UVLO (Under-voltage lockout) is used to keep the device off unless there is a valid input voltage present.

The UTC **U2076B** is used in application such as USB host and self-powered hubs, bus-powered hubs, hot plug-in power supplies and battery-charger circuits.

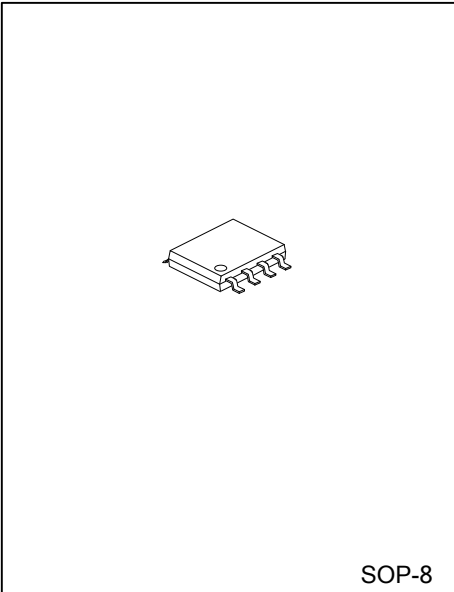

SOP-8

### FEATURES

- \* MOSFET with Low On-Resistance: 140mΩ max.@5.0V per Channel
- \* Continuous Load Current: 500mA (MIN.) per Channel
- \* Off-State Supply Current: 1μA (TYP.)
- \* Output can be Forced Higher than Input (Off-State)
- \* Current Limit up to 1.25A (MAX.)
- \* Input Supply Voltage: 3.0V ~ 5.5V
- \* On-State Supply Current: 110μA (TYP.)
- \* Thermal Shutdown Protection Circuit
- \* UVLO (Undervoltage Lockout): 2.4V (TYP.)
- \* Open-Drain Fault Flag
- \* 1ms Turn-On (Soft-Start) and Fast Turn-Off
- \* Compliant to USB Specifications
- \* Available with Active-High Enable

### ORDERING INFORMATION

Ordering Number	Package	Packing
US2076BG-S08-R	SOP-8	Tape Reel

<p>US2076BG-S08-R</p>	<p>(1)Packing Type</p> <p>(2)Package Type</p> <p>(3)Halogen Free</p>	<p>(1) R: Tape Reel</p> <p>(2) S08: SOP-8</p> <p>(3) G:Halogen Free</p>
-----------------------	--	---

■ **PIN CONFIGURATION**

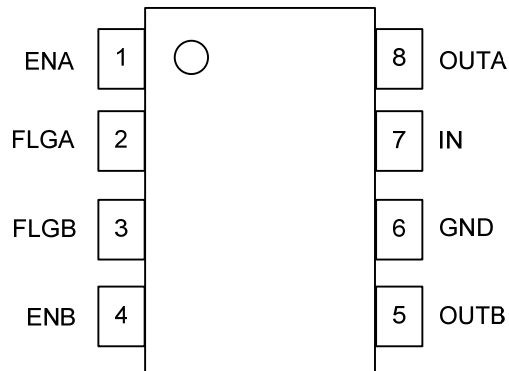

■ **PIN DESCRIPTION**

PIN NO.	PIN NAME	DESCRIPTION
1, 4	EN(A/B)	Enable (Input): Logic-compatible enable input. Active – High; Do Not Float.
2, 3	FLG(A/B)	Fault Flag (Output): Active-low, open-drain output. Indicates overcurrent, UVLO, and thermal shutdown.
6	GND	Ground: Supply return.
7	IN	Supply Input: Output MOSFET source. Also supplies IC's internal circuitry. Connect to positive supply.
5, 8	OUT(A/B)	Switch Output: Output MOSFET drain. Typically connect to switched side of load.

■ BLOCK DIAGRAM

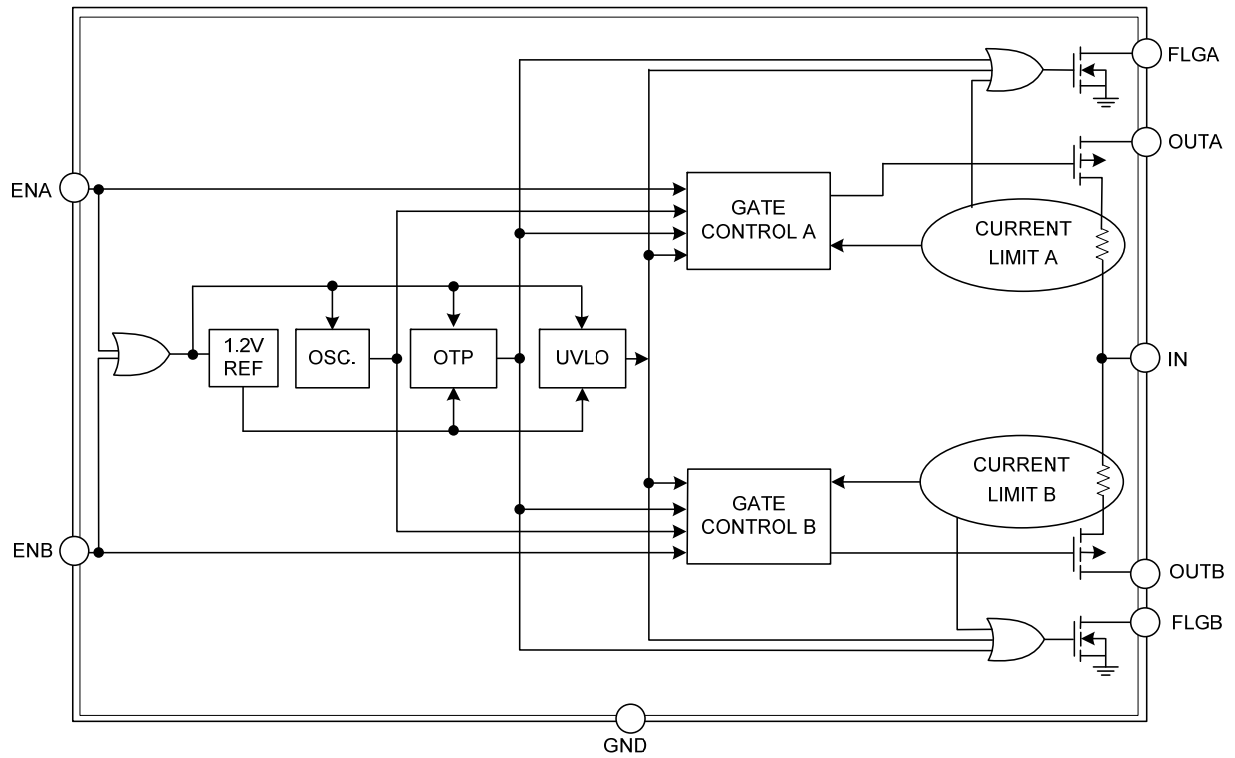

## ■ ABSOLUTE MAXIMUM RATING

PARAMETER	SYMBOL	RATINGS	UNIT
Output Current	$I_{OUT}$	Internally Limited	
Fault Flag Current	$I_{FLG}$	50	mA
Fault Flag Voltage	$V_{FLG}$	+6.0	V
Supply Voltage	$V_{IN}$	+6.0	V
Output Voltage	$V_{OUT}$	+6.0	V
Control Input	$V_{EN}$	-0.3 ~ 6	V
Storage Temperature	$T_{STG}$	-65 ~ +150	°C

Note: Absolute maximum ratings are those values beyond which the device could be permanently damaged. Absolute maximum ratings are stress ratings only and functional device operation is not implied.

## ■ OPERATING RATINGS

PARAMETER	SYMBOL	RATINGS	UNIT
Supply Voltage	$V_{IN}$	+3 ~ +5.5	V
Ambient Operating Temperature	$T_{OPR}$	-40 ~ +85	°C

## ■ THERMAL DATA

PARAMETER	SYMBOL	RATINGS	UNIT
Junction to Ambient	$\theta_{JA}$	160	°C/W

## ■ ELECTRICAL CHARACTERISTICS ( $V_{IN}=+5V$ , $T_A=25^\circ C$ , unless otherwise specified.)

PARAMETER	SYMBOL	TEST CONDITIONS	MIN	TYP	MAX	UNIT
Supply Current	$I_{S(OFF)}$	switch off, OUT = open		25		$\mu A$
	$I_{S(ON)}$	switch on, OUT = open		110		$\mu A$
Enable Input Threshold	$V_{IH}$	low to high transition		2.4	2.5	V
	$V_{IL}$	high to low transition	1.0	2.2		V
Enable Input Current	$I_{EN}$	$V_{EN} = V_{OH(min)} = 2.4V$		0.01	1	$\mu A$
		$V_{EN} = V_{OL(max)} = 0.8V$		0.01	1	$\mu A$
Enable Input Capacitance				1		pF
Switch Resistance	$R_{ON}$	$V_{IN} = 5V$		100		m $\Omega$
		$V_{IN} = 3V$		140		m $\Omega$
Output Turn-On Delay	$t_{ON(DLY)}$	$R_L = 10\Omega$ each output		1		ms
Output Turn-On Rise Time	$t_{RISE}$	$R_L = 10\Omega$ each output		0.5		ms
Output Turn-Off Delay	$t_{OFF(DLY)}$	$R_L = 10\Omega$ each output		1	20	$\mu s$
Output Turn-Off Fall Time	$t_{OFF}$	$R_L = 10\Omega$ each output		1	20	$\mu s$
Output Leakage Current	$I_{O(LEAK)}$	each output			10	$\mu A$
Short Circuit Current Limit	$I_{SHORT}$	each output	0.5	0.75	1.25	A
Overtemperature Shutdown Threshold	$OT_{Threshold}$	$T_J$ increasing		135		°C
		$T_J$ decreasing		125		°C
Error Flag Output Resistance		$V_{IN} = 5V, I_L = 10mA$		10		$\Omega$
		$V_{IN} = 3.3V, I_L = 10mA$		15		$\Omega$
Error Flag Off Current		$V_{FLAG} = 5V$		0.01	1	$\mu A$
UVLO Threshold	$V_{UVLO}$	$V_{IN} =$ increasing		2.5		V
		$V_{IN} =$ decreasing		2.3		V

## ■ FUNCTIONAL DESCRIPTION

The UTC **US2076B** is dual high-side switch with active-high enable inputs. Fault conditions turn off or inhibit turn-on one or both of the output transistors, controlling by the type of fault, and the FLG pin is pulled to ground by being activated the open-drain error flag transistors.

### Input and Output

IN (input) is the power supply connection to the logic circuitry and the source of the output MOSFET. OUTx (output) is the drain of the output A or B MOSFET.

IN pin (input) is the power supply connection to the logic circuitry and the source of the output MOSFET. OUT pin (output) is the output MOSFET's drain. Current flows through the switch from IN pin to OUT pin toward the load in many applications. All OUT pins must be connected together to the load.

The output MOSFET and driver circuit are also designed to allow the MOSFET drain to be externally forced to a higher voltage than the source ( $V_{OUT} > V_{IN}$ ) when the switch is off. This avoids undesirable drain-to-body diode current flow by connecting the body to the most positive voltage. If  $V_{OUT} > V_{IN}$  when switch is enabled, current will flow from  $V_{OUT}$  to  $V_{IN}$ .

### Thermal Shutdown

Thermal shutdown is designed to prevent this device from being damaged due to excessive power dissipation. It is used to turn off the output MOSFET if the temperature is higher than 135°C, 10°C of hysteresis prevents the switch from turning on until the die temperature drops to 125°C. Thermal shutdown circuit functions only when the switch is enabled.

### Undervoltage Lockout

UVLO (Undervoltage Lockout) turns off the MOSFET switch and signals the fault flag pin once the input voltage falls below 2.3V (TYP.) and if the input voltage exceeds 2.5V (TYP.), the switch will be turned on. UVLO detection functions only when the switch is enabled.

### Current Sensing and Limiting

The current limit threshold is fixed internally, allowing a 0.5A minimum current to flow through the output MOSFET. However, the current limit threshold can prevent the output MOSFET and external load from being damage. A current sense circuit protects the MOSFET switch's output current. If output current becomes higher than the current limit threshold, the output MOSFET switch is turned off and a fault flag is pulled low. The reaction to an overcurrent is measured with the following scenarios:

#### Switch Enable into Heavy Load

If a switch is powered-on or enabled into a heavy load or short-circuit, the switch immediately goes into a constant-current mode, reducing output voltage. The fault flag goes low until the load is reduced or thermal shutdown occurs.

If the switch is powered on or enabled into a heavy load or short-circuit, the switch enters a constant-current mode immediately, reducing the output voltage. The fault flag drops low until thermal shutdown occurs or the load is reduced.

#### Heavy Load Applied Suddenly to Enabled Switch

When a heavy load is applied, a large-undesired transient current occurs which may damage the switch. Then the current limit circuit may turn off the switch, folding back into constant-current mode. In that case, the fault flag falls until the load is reduced.

### Fault Flag

Fault flag is an open-drained output of an N-channel MOSFET. It drops low to indicate error conditions as follows: current limiting, UVLO, or thermal shutdown. The flag output MOSFET is capable of sinking a 10mA load to typically 100mV above ground. Both flag pins may be "wire-NORed" to a common pullup resistor.

■ APPLICATIONS INFORMATION

Supply filtering

In order to control supply transients, a bypass capacitor is located nearly between IN to GND. 0.1μF ~ 1μF is suitable (See Figure 1). Without a bypass capacitor, an output short may cause sufficient ringing on the input (from supply lead inductance) to damage internal control circuitry.

Input transients must not exceed the absolute maximum supply voltage ( $V_{IN\ max} = 6V$ ) even for a short duration. 4.0V~5.5V

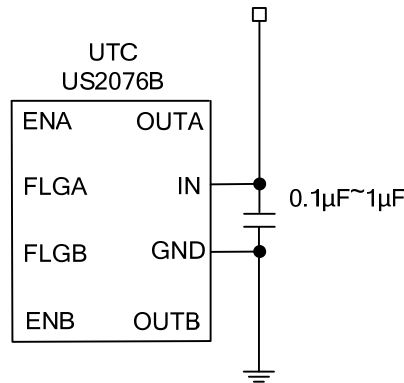

Figure 1. Supply Bypassing

Enable Input

For a clearly defined input, the EN pin must be driven logic high or logic low. Floating the input may cause unpredictable operation. EN should not be allowed to go negative with respect to GND.

Soft Start

The UTC **US2076B** is high impedance when off and slowly becomes a low impedance as it turns on. This reduces inrush current and related voltage drop that results from charging a capacitive load, satisfying the USB voltage drop requirements, for bus-powered applications as shown in Figure 2.

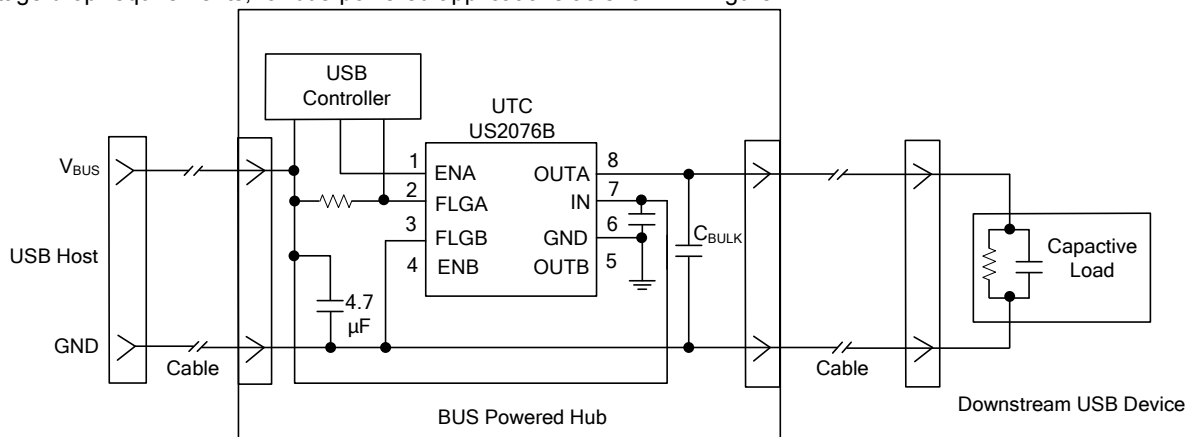

Figure 2. Soft Start (Single Channel)

■ APPLICATIONS INFORMATION (Cont.)

In Figure 3, the soft start circuit is shown, and the soft start circuit can be utilized to meet USB transient regulation specifications with large load capacitances ( $C_{BULK} > 10\mu F$ ). The device will provide inrush current limiting for these applications.

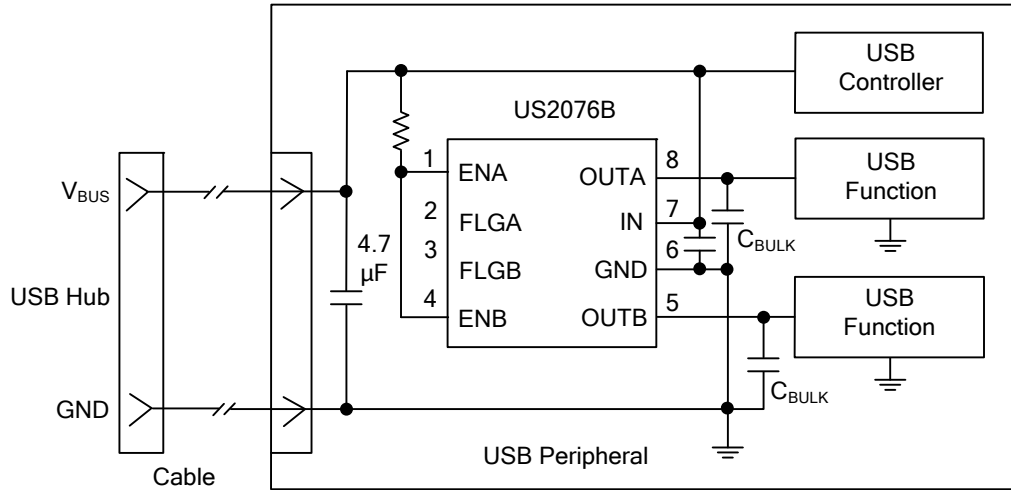

Figure 3. Inrush Current-Limit Application

If an inrush current which is from the connection of a heavy capacitive load, the inrush current may cause the fault flag to fall for a short duration, while the switch is in a constant-current mode, or charging the capacitance. In that case, to protect this circuit from damage due to erroneous overcurrent reporting, the fault flag circuit can be in series with a simple 1ms RC low-pass filter (see Figure 4)

Transient Overcurrent Filter

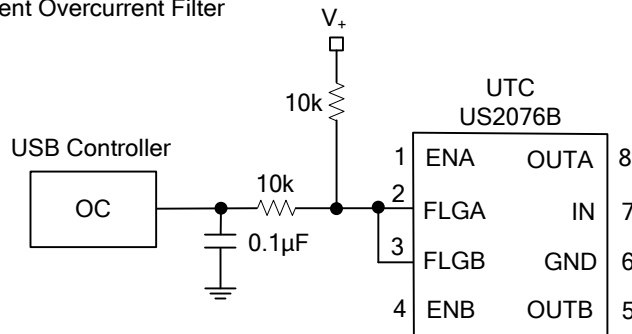
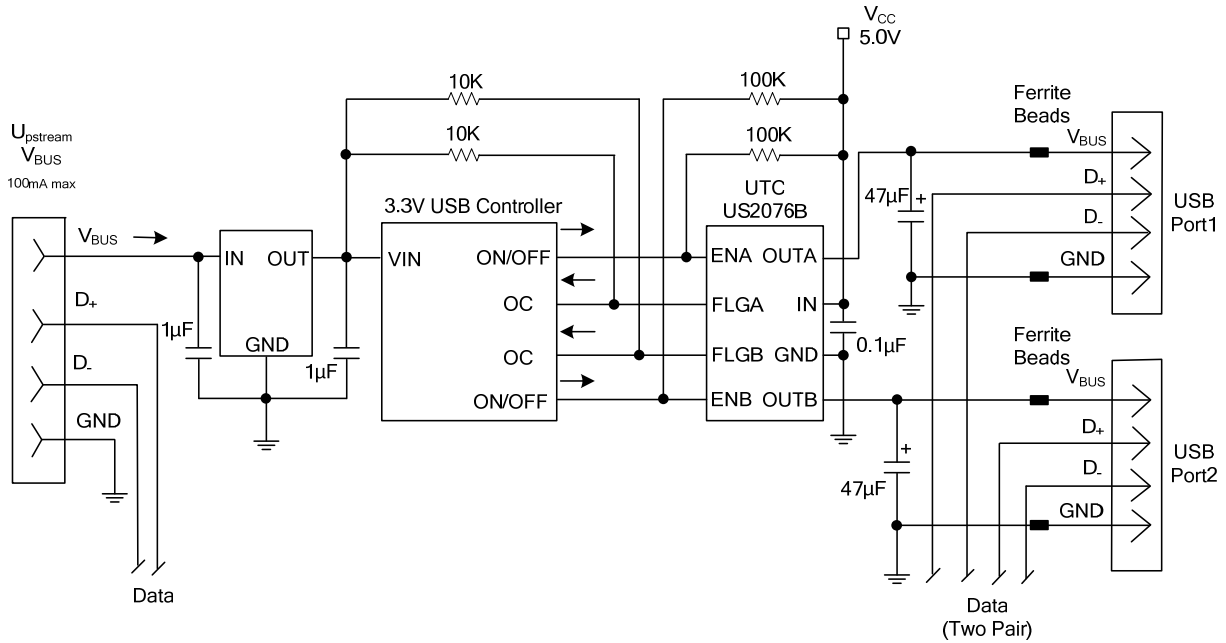

Figure 4. Transient Filter

■ TYPICAL APPLICATION CIRCUIT



UTC assumes no responsibility for equipment failures that result from using products at values that exceed, even momentarily, rated values (such as maximum ratings, operating condition ranges, or other parameters) listed in products specifications of any and all UTC products described or contained herein. UTC products are not designed for use in life support appliances, devices or systems where malfunction of these products can be reasonably expected to result in personal injury. Reproduction in whole or in part is prohibited without the prior written consent of the copyright owner. The information presented in this document does not form part of any quotation or contract, is believed to be accurate and reliable and may be changed without notice.