



# US3X77

CMOS IC

## POWER DISTRIBUTION SWITCH

### DESCRIPTION

The UTC **US3X77** is a power distribution switch and particularly designed for self-powered and bus-powered Universal Serial Bus (USB) applications.

The UTC **US3X77** incorporates protection circuits including current limiting circuit with foldback function, thermal shutdown circuit designed to prevent catastrophic switch failure due to increasing power dissipation when continuous heavy loads or short circuit occurs. Besides, a built-in charge pump is used to drive the N-channel MOSFET that is free of parasitic body diode to eliminate any reversed current flow across the switch when it is powered off.

The  $R_{DS(ON)}$  of the MOSFET switch is as low as 100mΩ.  $\overline{OC}$  is open-drain output report over-current or over-temperature event which has deglitch typical 9ms timeout period typically 9ms.

The UTC **US3X77** is applied in high-side power protection switch, USB power management, USB host and self-powered hubs, USB bus-powered hubs, hot plug-in power supplies, battery-charger circuits.

### FEATURES

- \* 100mΩ High-Side MOSFET
- \* Supply Current:
  - Switch on : 65μA(Typ)
  - Switch off : 1μA (Max)
- \* Accurate Current Limit with Foldback
- \* Deglitched Open-Drain Over-Current Flag Output ( $\overline{OC}$ )
- \* No Reverse Current when Power Off
- \* Under voltage Lockout
- \* Operating Range:2.7V ~ 5.5V
- \* Output Shutdown Pull-low Resistor

### ORDERING INFORMATION

Ordering Number		Package	Packing
Lead Free	Halogen Free		
US3X77XL-S08-R	US3X77XG-S08-R	SOP-8	Tape Reel
US3X77XL-S08-T	US3X77XG-S08-T	SOP-8	Tube
US3X77XL-SM1-R	US3X77XG-SM1-R	MSOP-8	Tape Reel
US3X77XL-SM1-T	US3X77XG-SM1-T	MSOP-8	Tube

<p>US3X77XL-S08-R</p>	<p>(1) R: Tape Reel, T: Tube          (2) S08: SOP-8, SM1: MSOP-8          (3) G: Halogen Free, L: Lead Free          (4) H: Active High, L: Active Low          (5) 1: 1A, 2: 1.5A, 3:2.0A, 4: 2.5A</p>
-----------------------	--

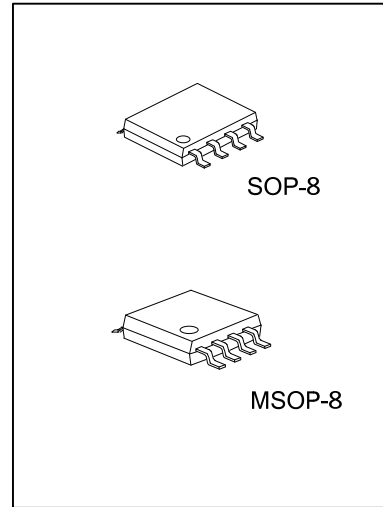

## ■ PIN CONFIGURATION

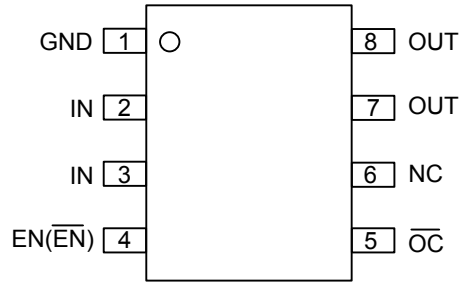

## ■ PIN DESCRIPTION

PIN NO.	PIN NAME	DESCRIPTION
1	GND	Ground
2, 3	IN	Input Supply: Output MOSFET Drain, which also supplies IC's internal circuitry. Connect to positive supply.
4	EN( $\overline{\text{EN}}$ )	Enable: Logic level enable input. Make sure EN pin never floating.
5	$\overline{\text{OC}}$	Over-Current: Open-Drain $\overline{\text{OC}}$ output.
6	NC	No connection.
7, 8	OUT	Switch Output: Output MOSFET Source of switch. Typically connect to switched side of load.

## ■ BLOCK DIAGRAM

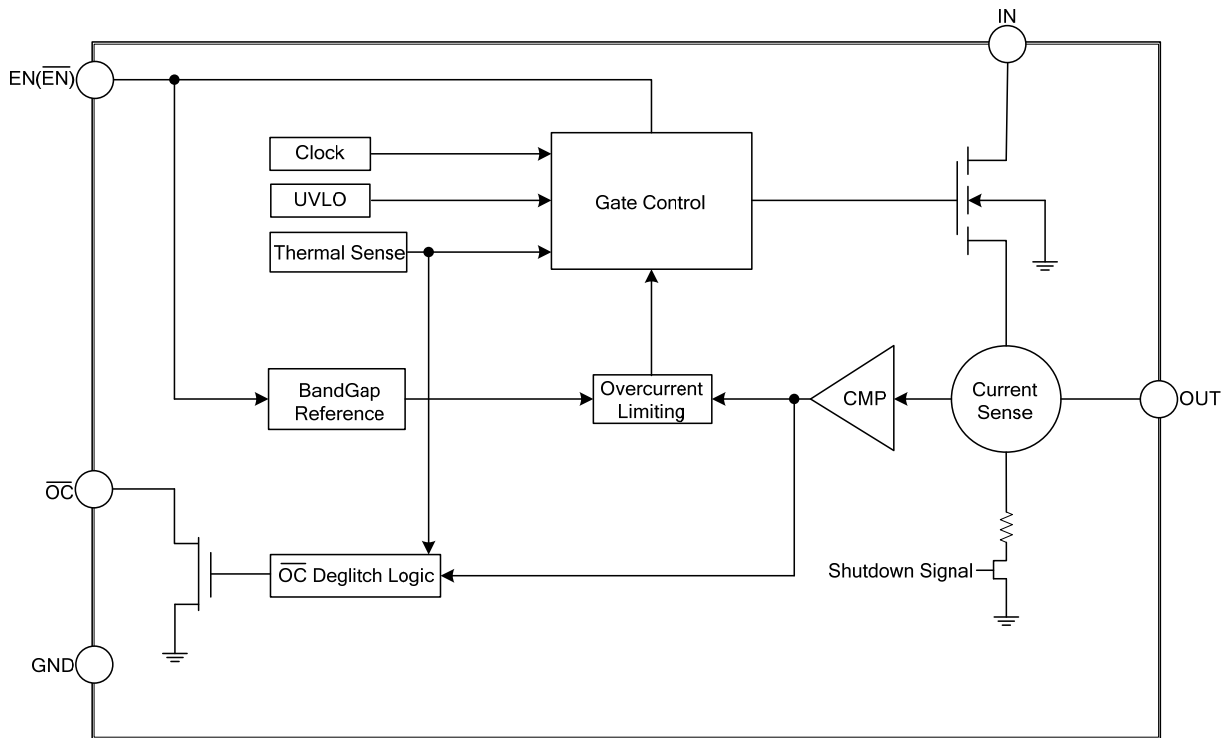

## ■ ABSOLUTE MAXIMUM RATING (T<sub>A</sub> = 25°C, unless otherwise specified)

PARAMETER	SYMBOL	RATINGS	UNIT
Supply Voltage	V <sub>IN</sub>	6	V
Output Voltage	V <sub>OUT</sub>	6	V
Enable Input	V <sub>EN</sub>	-0.3 ~ 6	V
Output Current	I <sub>OUT</sub>	Internally Limited	A
Storage Temperature	T <sub>STG</sub>	-65~ +150	°C
Reflow Temperature (Soldering, 10sec)		260	°C
ESD Protection		2	kV

Note: Absolute maximum ratings are those values beyond which the device could be permanently damaged.

Absolute maximum ratings are stress ratings only and functional device operation is not implied.

## ■ OPERATING RATINGS

PARAMETER	SYMBOL	RATINGS	UNIT
Supply Voltage	V <sub>IN</sub>	+3 ~ +5.5	V
Operating Temperature	T <sub>A</sub>	-40 ~ +85	°C

## ■ ELECTRICAL CHARACTERISTICS

(V<sub>IN</sub> = 5V, C<sub>IN</sub>=1μF, C<sub>OUT</sub>=1μF, R<sub>L</sub>=10Ω, T<sub>A</sub> = 25°C, unless otherwise specified)

PARAMETER	SYMBOL	TEST CONDITIONS	MIN	TYP	MAX	UNIT	
Input Voltage	V <sub>IN</sub>		2.7		5.5	V	
Output MOS R <sub>DS(ON)</sub>		US3477, I <sub>OUT</sub> =1.5A		100	115	mΩ	
		US3377, I <sub>OUT</sub> =1.0A					
		US3277, I <sub>OUT</sub> =0.5A					
		US3177, I <sub>OUT</sub> =0.3A					
Supply Current	I <sub>IN</sub>		65			μA	
Output Turn-on Rising Time		R <sub>L</sub> =10Ω, 90% Settling		400		μs	
Current Limit Threshold	I <sub>THD(LIMIT)</sub>	V <sub>OUT</sub> =4V	US3477	2	2.5	3.3	A
			US3377	1.6	2	2.6	
			US3277	1.2	1.5	1.9	
			US3177	0.75	1	1.45	
Short-Circuit Current	I <sub>SC</sub>	V <sub>OUT</sub> =0V, 2.7V<V <sub>IN</sub> <5.5V	US3477	0.2	1.7	2.3	A
			US3377	0.2	1.3	1.7	
			US3277	0.2	1	1.3	
			US3177	0.2	0.7	0.9	
EN Input Threshold			1	1.6	1.8	V	
Shutdown Supply Current	I <sub>SHDN</sub>			0.1	1	μA	
Shutdown Pull Low Resistance				75	150	Ω	
Output Leakage Current	I <sub>O(LEAK)</sub>	EN="0", V <sub>OUT</sub> =0V		0.5	1	μA	
V <sub>IN</sub> Under Voltage Lockout			2.2	2.5	2.7	V	
V <sub>IN</sub> Under Voltage Hysteresis				200		mV	
Thermal Limit				135		°C	
Thermal Limit Hysteresis				20		°C	
OC Deglitch		OC assertion or deassertion	4	9	15	ms	
OC Output Low Voltage		I <sub>OC</sub> = 5mA			0.4	V	
OC Off-State Current		V <sub>OC</sub> = 5V			1	μA	

## ■ FUNCTIONAL DESCRIPTION

### OVERCURRENT PROTECTION

When the output load exceeds the current-limit threshold, The Over Current Protection will be triggered. The typical current limit value of UTC **US3077/US3277/US3377/US3477** is 1A, 1.5A, 2A, 2.5A. There is foldback of current limit when short-circuit being encountered.

### $\overline{\text{OC}}$ RESPONSE

The  $\overline{\text{OC}}$  open-drain output is asserted (active low) when an over current or over-temperature shutdown condition is encountered after a 9-ms deglitch timeout. The output remains asserted until the over-current or over-temperature condition is removed.

### THERMAL SHUTDOWN

Thermal shutdown protects UTC **US3X77** from excessive power dissipation. If the die temperature exceeds 135°C, the MOSFET switch is shut off. 20°C of hysteresis prevents the switch from turning on until the die temperature drops to 115°C. Thermal shutdown circuit functions only when the switch is enabled.

### UNDERVOLTAGE LOCKOUT (UVLO)

UVLO (under-voltage lockout) prevents the output MOSFET from turning on until IN (input voltage) exceeds 2.5V typically. After the switch turns on, if the voltage drops below 2.3V typically, UVLO shuts off the output MOSFET.

■ TEST CIRCUITS

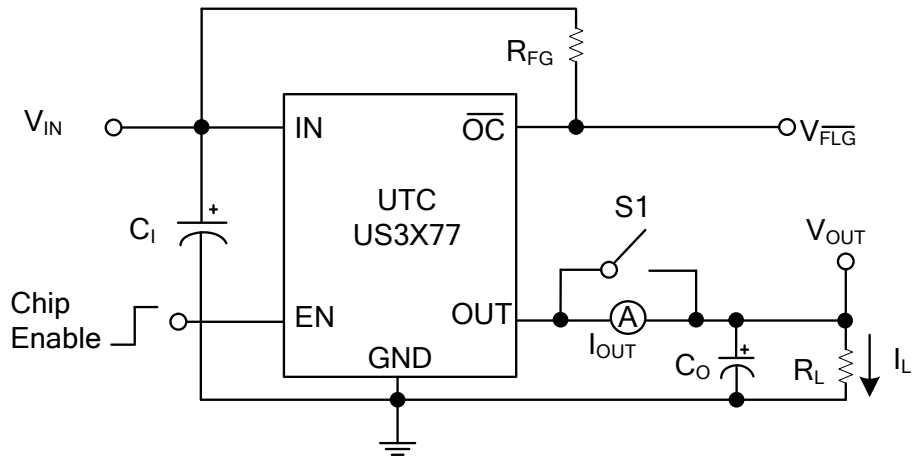

Turn-On & Off Response, Flag Response

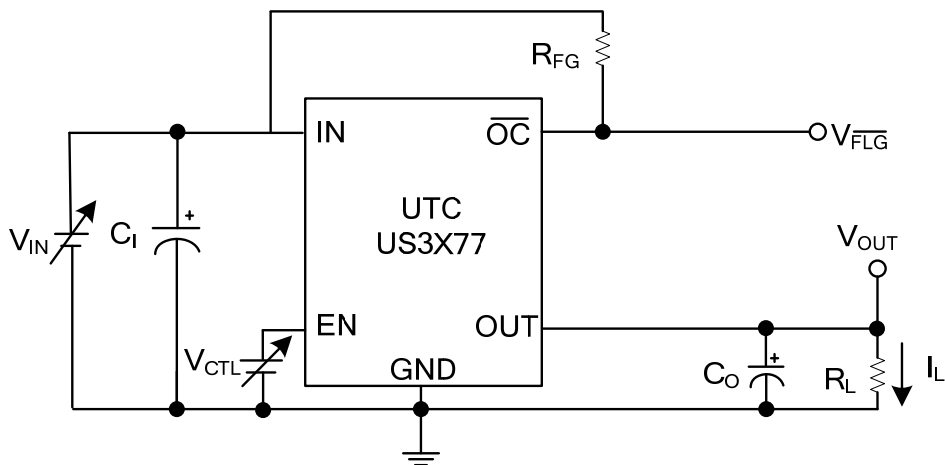

UVLO at Rising & Falling

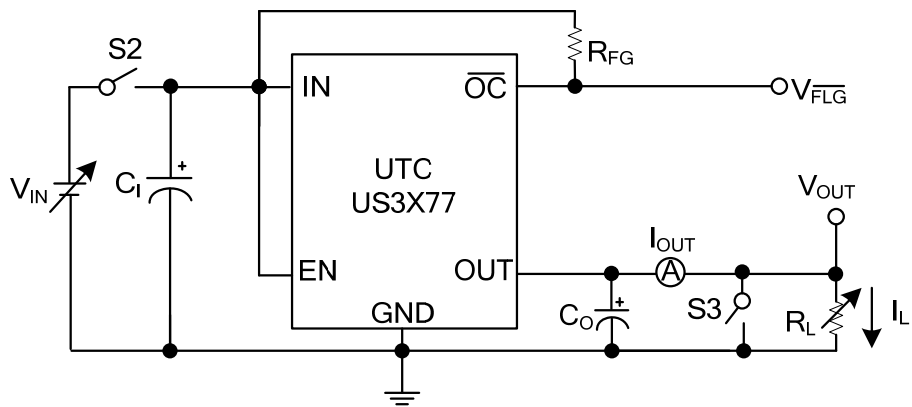

Current Limit vs. Input Voltage, Inrush Current Response, Current Limit Transient Response

■ TYPICAL APPLICATION CIRCUIT

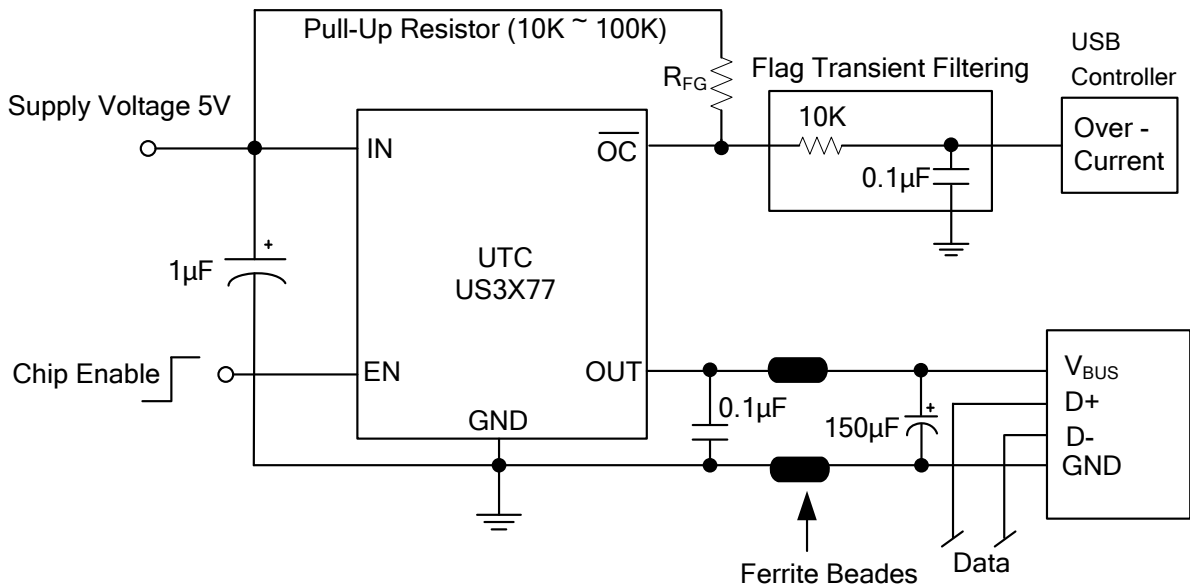

Note. A low-ESR 150µF aluminum electrolytic or tantalum between  $V_{OUT}$  and GND is strongly recommended to meet the 330mV maximum droop requirement in the hub  $V_{BUS}$ .

**POWER SUPPLY CONSIDERATIONS**

A 1µF bypass capacitor on IN pins, a high value capacitor and a 0.1µF bypass capacitor on OUT pins, are strongly recommended, because this precaution can reduce a poor risk that an output short may cause sufficient ringing on the input to damage internal control circuitry.

Input transients must not exceed the absolute maximum supply voltage (6V) even for a short duration.

**ENABLE INPUT**

EN must be driven logic high or logic low for a clearly defined input. Floating the input may cause unpredictable operation. EN should not be allowed to go negative with respect to GND.

## TYPICAL CHARACTERISTICS

( $T_A=25^\circ\text{C}$ ,  $V_{IN}=5\text{V}$ , 3275H,  $C_{IN}=1\mu\text{F}$ ,  $C_{OUT}=1\mu\text{F}$ ,  $V_{EN}=0\text{V}$ , unless otherwise specified.)

Turn on delay time and rise time

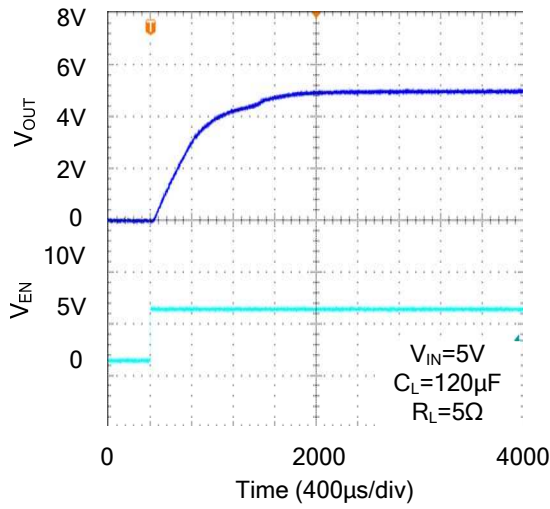

Turn off delay time and fall time

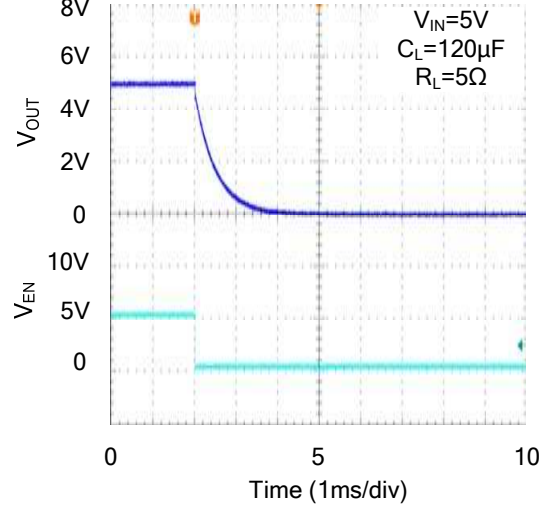

Inrush Current With Different Load Capacitance

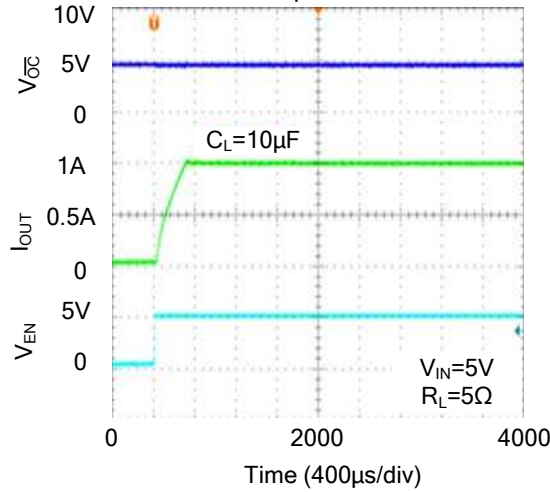

Inrush Current With Different Load Capacitance

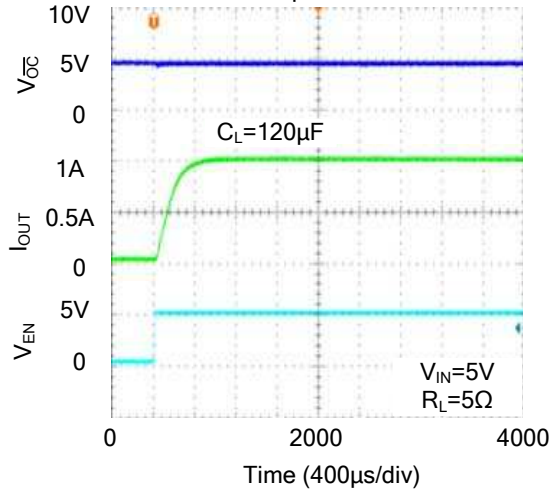

Inrush Current With Different Load Capacitance

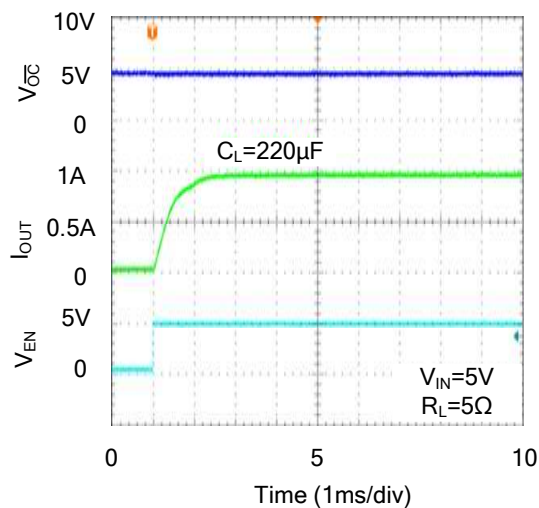

Thermal Shutdown Response

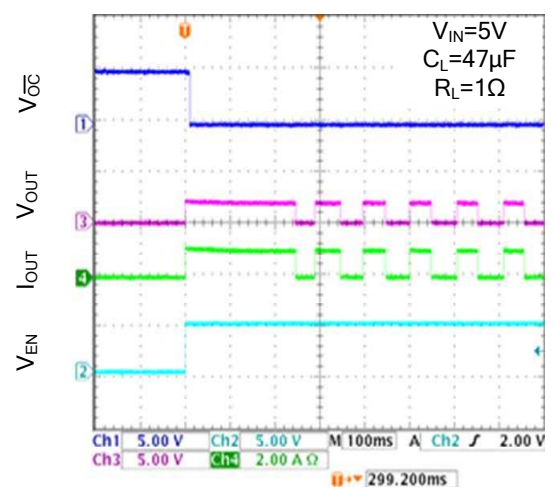

## ■ TYPICAL CHARACTERISTICS (Cont.)

UVLO protection at rising

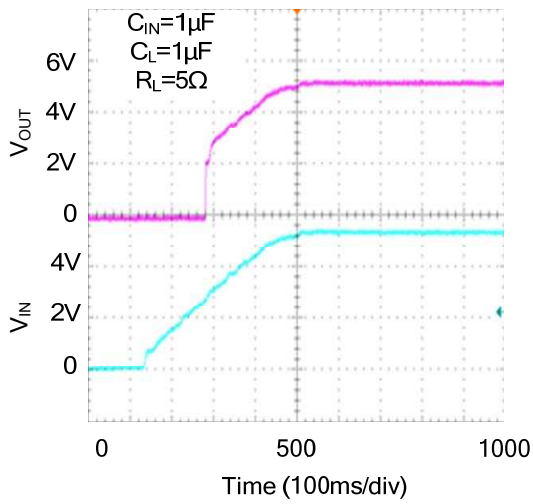

UVLO protection at falling

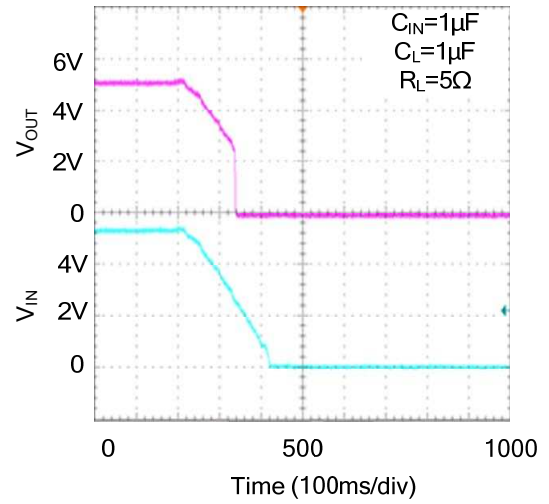

Short circuit response at start up

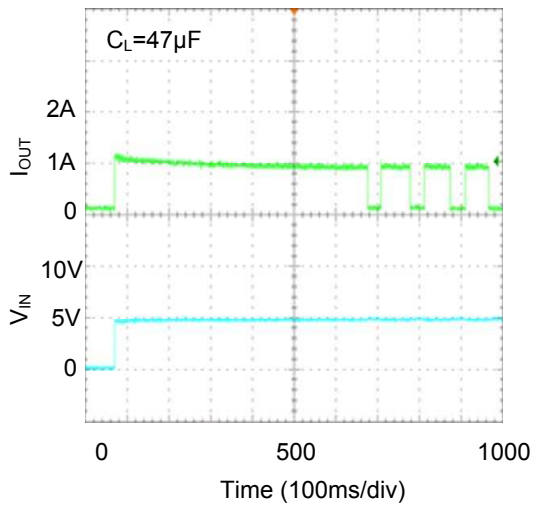

Short-circuit current, device enable into short

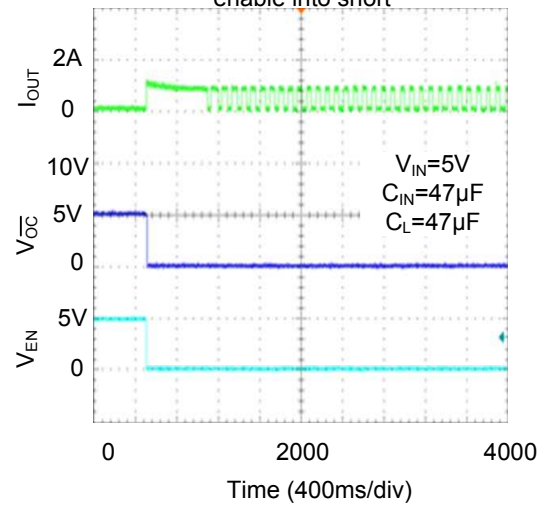

Inrush short circuit response

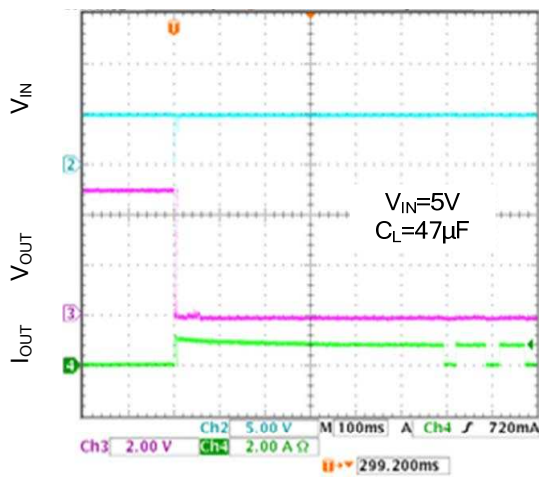

Capacitance Load Inrush Response

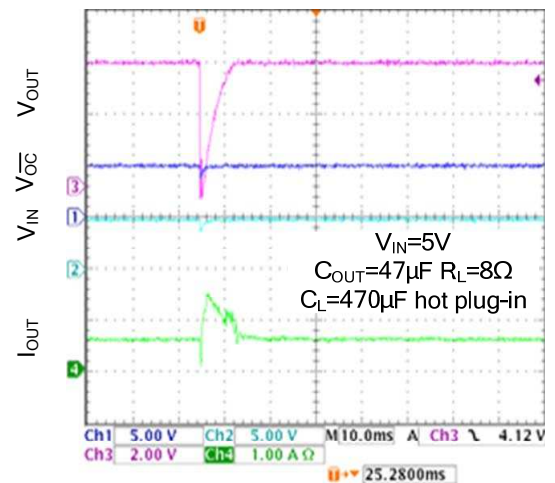

■ TYPICAL CHARACTERISTICS (Cont.)

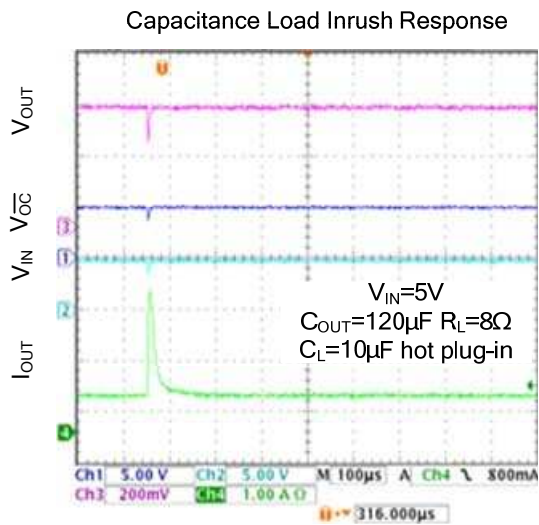

UTC assumes no responsibility for equipment failures that result from using products at values that exceed, even momentarily, rated values (such as maximum ratings, operating condition ranges, or other parameters) listed in products specifications of any and all UTC products described or contained herein. UTC products are not designed for use in life support appliances, devices or systems where malfunction of these products can be reasonably expected to result in personal injury. Reproduction in whole or in part is prohibited without the prior written consent of the copyright owner. The information presented in this document does not form part of any quotation or contract, is believed to be accurate and reliable and may be changed without notice.