



UC3380

CMOS IC

PWM STEP UP DC-DC CONTROLLER

DESCRIPTION

The UC3380 is PWM step up DC-DC switching controller that operates from 0.9V. The low start up input voltage makes UC3380 specially designed for powering portable equipment from one or two cells battery packs. This device consist of a soft start circuit, a reference voltage source, an error amplifier, an oscillator, a phase compensation, a PWM controller and an output drive circuit for driving external power transistor.

Additionally, a chip enable feature is provided to power down the converter for extended battery life. The device features a voltage mode PWM control loop, providing stable and high efficiency operation over a broad load current range.

FEATURES

- * 0.9V Low Start-Up Input Voltage at 1mA Load
- * Low Operation Current
- * 0.5uA Low Shutdown Current
- * Fix Frequency PWM at 300KHZ
- * Built in PWM Switching Control Circuit ,Duty Ratio is 0~78%
- * Output Voltage:0.1V Step Setting is Available Between 2.0V and 6.5V
- * Soft Start Time: 3ms
- * Shutdown Function

APPLICATIONS

- *Portable Devices
- *Electronic Games
- *Portable Audio (MP3)
- *Personal Digital Assistant (PDA)
- *Digital still Cameras(DSC)
- *Camcorders
- *White LED Driver
- *Single and Dual-Cell Battery Operated Products

ORDERING INFORMATION

Ordering Number		Package	Packing
Lead Free	Halogen Free		
UC3380L-xx-AF5-R	UC3380G-xx-AF5-R	SOT-25	Tape Reel

<p>UC3380L-xx-AF5-R</p> <ul style="list-style-type: none"> (1)Packing Type (2)Package Type (3)Output Voltage Code (4)Lead Free 	<ul style="list-style-type: none"> (1) R: Tape Reel (2) AF5: SOT-25 (3) xx: refer to Marking Information (4) G: Halogen Free, L: Lead Free
--	--

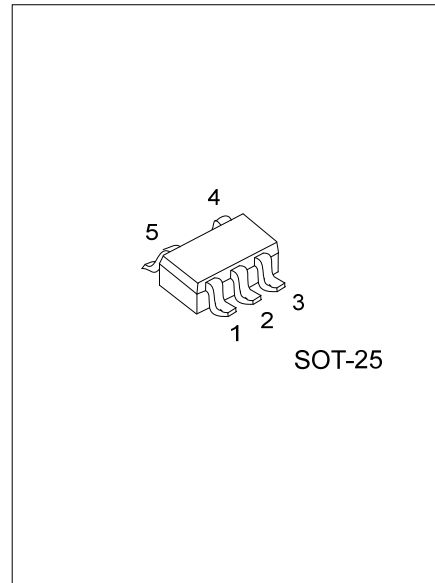

MARKING INFORMATION

PACKAGE	VOLTAGE CODE	MARKING
SOT-25	18:1.8V	
	21:2.1V	
	25:2.5V	
	27:2.7V	
	30:3.0V	
	33:3.3V	
	40:4.0V	
50:5.0V		

PIN DESCRIPTION

PIN NO	NAME	DESCRIPTION
1	SHUTDOWN	Shutdown control input, "H" : normal operation "L" : stop step up(whole circuit stop).
2	V _{OUT}	Power supply and voltage output.
3	NC	No connection.
4	V _{SS}	Ground.
5	EXT	Switching the circuit by connecting to a transistor.

BLOCK DIAGRAM

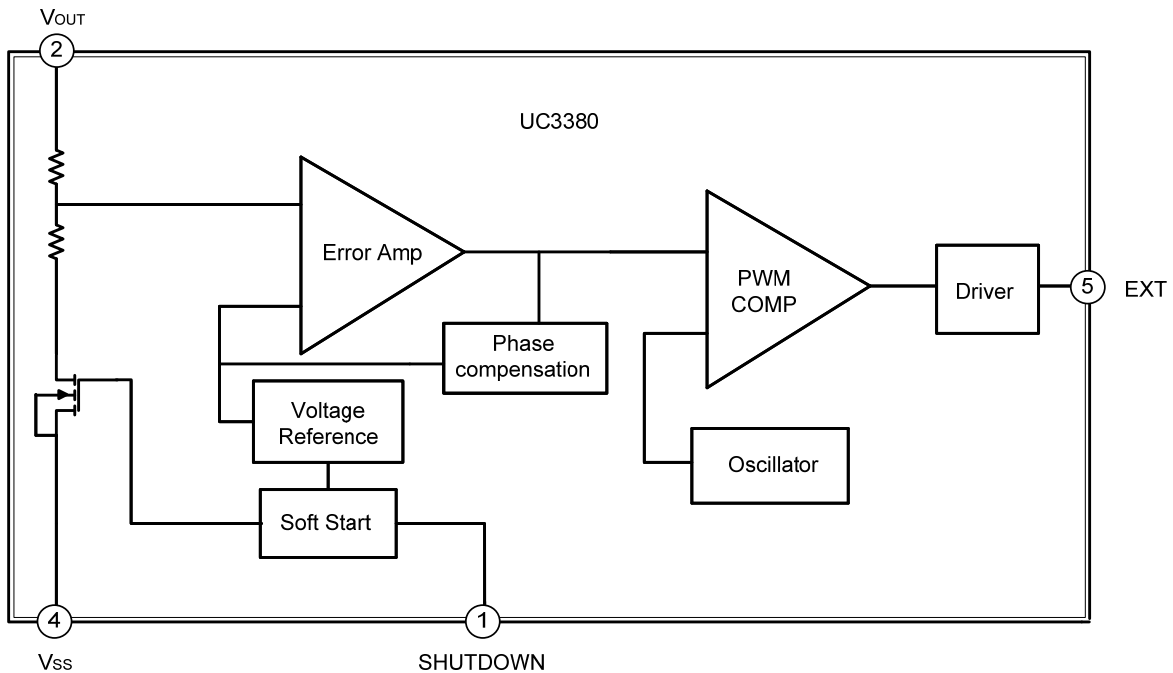

■ ABSOLUTE MAXIMUM RATINGS

PARAMETER	SYMBOL	RATINGS	UNIT
V _{OUT} Pin Voltage	V _{OUT}	12	V
SHUTDOWN Pin Voltage	V _{SHUTDOWN}	V _{SS} -0.3~12	V
EXT Pin Voltage	V _{EXT}	-0.3~ V _{OUT} +0.3	V
EXT Pin Current	I _{EXT}	±80	mA
Power Dissipation	P _D	250	mW
Operating Ambient Temperature	T _{OPR}	-40~+85	°C
Storage Temperature	T _{STG}	-40~ +125	°C

Note: Absolute maximum ratings are those values beyond which the device could be permanently damaged. Absolute maximum ratings are stress ratings only and functional device operation is not implied.

■ ELECTRICAL CHARACTERISTICS

Refer to the test circuit, T_{OPR}=25°C, V_{IN}=V_{OUT} (S)*0.6, I_{OUT}=V_{OUT} (S)/50Ω, unless otherwise specified.

PARAMETER	SYMBOL	TEST CIRCUIT	TEST CONDITION	MIN	TYP	MAX	UNIT
TOTAL DEVICE							
Output Voltage	V _{OUT}	2		V _{OUT} (S)*0.976	V _{OUT} (S)	V _{OUT} (S)*1.024	V
Supply Current 1	I _{S1}	1	V _{OUT} = V _{OUT} (S)*0.95	V _{OUT} (S)15 to 19	33.8	56.4	uA
				V _{OUT} (S)20 to 29	50.3	83.9	
				V _{OUT} (S)30 to 39	68.6	114.4	
				V _{OUT} (S)40 to 49	88.4	147.4	
				V _{OUT} (S)50 to 59	109.4	182.4	
Supply Current 2	I _{S2}	1	V _{OUT} = V _{IN} (S)+0.5V	V _{OUT} (S)15 to 19	9.7	19.4	uA
				V _{OUT} (S)20 to 29	9.9	19.7	
				V _{OUT} (S)30 to 39	10.0	20.0	
				V _{OUT} (S)40 to 49	10.2	20.4	
				V _{OUT} (S)50 to 59	10.4	20.7	
V _{OUT} (S)60 to 65	10.5	21.0					
Input Voltage	V _{IN}	2				10	V
Operation Holding Voltage	V _{HOLD}	2	Measured by decreasing V _{IN} voltage gradually, when I _{OUT} =1mA.	0.7			V
Operation Start Voltage	V _{ST1}	2	I _{OUT} =1mA			0.9	V
Oscillation Start Voltage	V _{ST2}	1	Increase the V _{IN} until EXT pin output the oscillating signal			0.8	V
Oscillation Frequency	f _{OSC}	1	V _{OUT} =V _{OUT} (S)*0.95	255	300	345	KHz
Duty Ratio	Duty	1	V _{OUT} =V _{OUT} (S)*0.95	70	78	85	%
Line Regulation	ΔLNR	2	V _{IN} =V _{OUT} (S)*0.4 to *0.6		30	60	mV
Load Regulation	ΔLDR	2	I _{OUT} =10uA to V _{OUT} (S)/50*1.25		30	60	mV
Temperature Coefficient	E _T	2	ΔV _{OUT} /(ΔT _{OPR} *V _{OUT}) T _{OPR} =-40°C ~ +85°C		±50		ppm/°C
Efficiency	E _F	2			85		%
Soft Start time	T _S	2		1.5	3.0	6.0	ms

■ ELECTRICAL CHARACTERISTICS

PARAMETER	SYMBOL	TEST CIRCUIT	TEST CONDITION	MIN	TYP	MAX	UNIT
SHUTDOWN							
Shutdown Supply Current	I_{SS}	1	$V_{SHUTDOWN}=0$			0.5	μA
Shutdown Pin Input Current	I_{SH}	1	$V_{SHUTDOWN}=V_{OUT(S)}*0.95$			0.1	μA
	I_{SL}		$V_{SHUTDOWN}=0$			-0.1	μA
Shutdown Pin Input Voltage Threshold	V_{IH}	1	Shutdown pin "L" to "H" until EXT output oscillating signal	0.75			V
	V_{IL1}		Shutdown pin "H" to "L" until EXT output oscillating signal	$V_{OUT} \geq 1.5V$		0.3	V
	V_{IL2}		$V_{OUT} < 1.5V$		0.2	V	
EXT							
EXT Pin Current	I_{EXTH}	1	$V_{EXT} = V_{OUT(S)} - 0.4V$	$V_{OUT(S)} 15$ to 19	-4.5	-8.9	mA
				$V_{OUT(S)} 20$ to 24	-6.2	-12.3	
				$V_{OUT(S)} 25$ to 29	-7.8	-15.7	
				$V_{OUT(S)} 30$ to 39	-10.3	-20.7	
				$V_{OUT(S)} 40$ to 49	-13.3	-26.7	
				$V_{OUT(S)} 50$ to 59	-16.1	-32.3	
				$V_{OUT(S)} 60$ to 65	-18.9	-37.7	
	I_{EXTL}	1	$V_{EXT} = 0.4V$	$V_{OUT(S)} 15$ to 19	9.5	19.0	mA
				$V_{OUT(S)} 20$ to 24	12.6	25.2	
				$V_{OUT(S)} 25$ to 29	15.5	31.0	
				$V_{OUT(S)} 30$ to 39	19.2	38.5	
				$V_{OUT(S)} 40$ to 49	23.8	47.6	
				$V_{OUT(S)} 50$ to 59	27.4	54.8	
				$V_{OUT(S)} 60$ to 65	30.3	60.6	

Note: $V_{OUT(S)}$ is the value of the set output voltage.

APPLICATION CIRCUIT

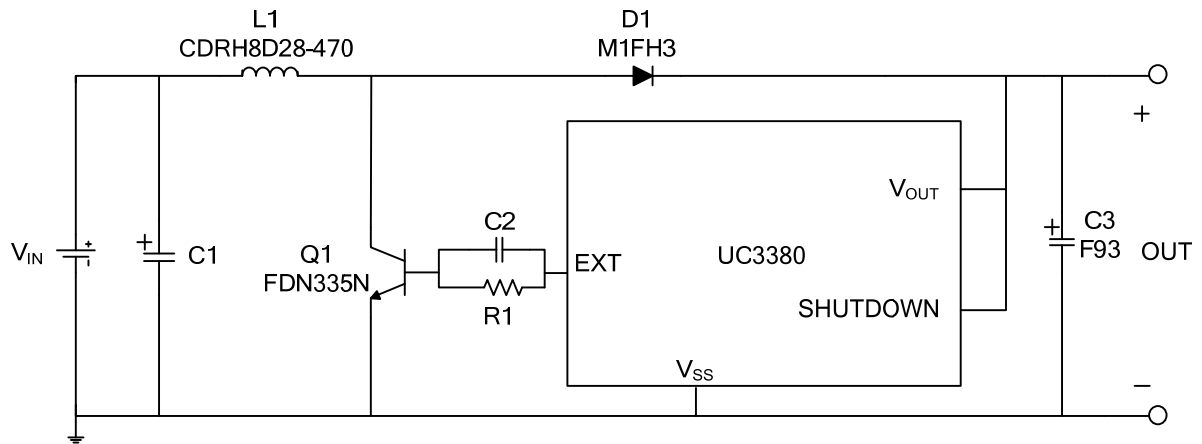

TEST CIRCUIT

1.

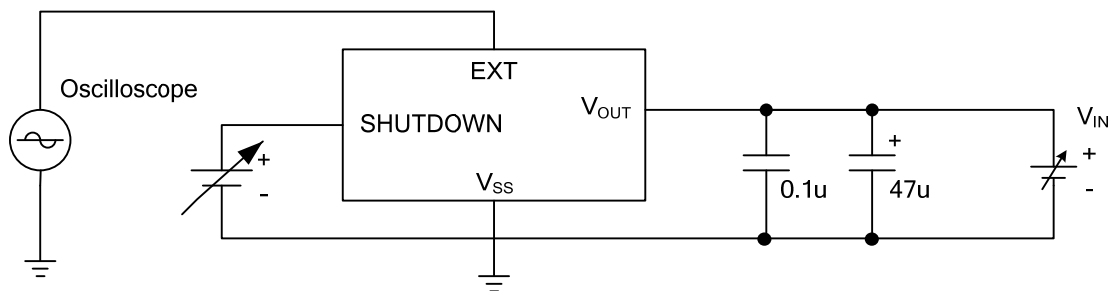

2.

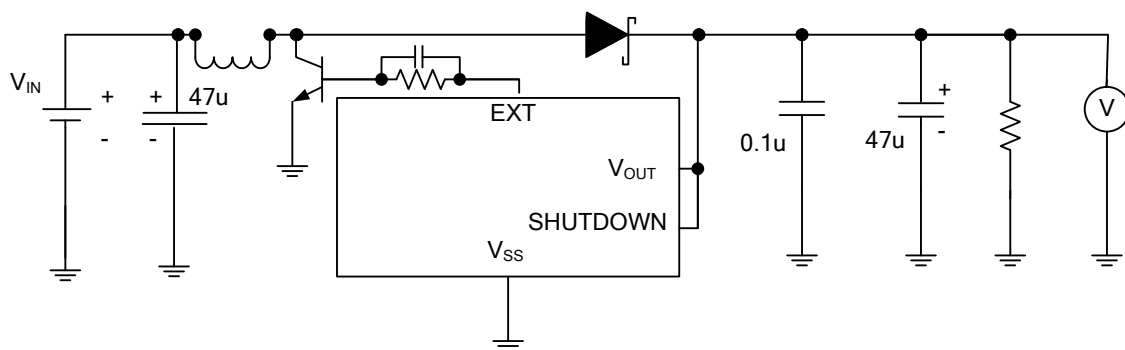

■ APPLICATION CIRCUIT INFORMATION

The following equations show the relation of the basic design parameters.

1. Refer to the application circuit, the increasing inductor current when the switch is turn on is given by the following equation

$$\Delta i_L^+ = \frac{1}{L} U_L T_{ON} = \frac{1}{L} (U_{IN} - U_S) \frac{d}{f} \quad (U_{IN} : \text{input voltage}; U_S : \text{transistor saturation voltage})$$

The decreasing inductor current when the switch is turn off can derive by the equation below

$$\Delta i_L^- = \frac{1}{L} U_L T_{OFF} = -\frac{1}{L} (U_O + U_D - U_{IN}) \frac{1-d}{f} \quad (U_D : \text{diode forward voltage})$$

according to $\Delta i_L^+ + \Delta i_L^- = 0$, the duty ratio is given by

$$d = \frac{U_O + U_D - U_{IN}}{U_O + U_D - U_S}$$

2. The average current flowing through the inductor is $I_L = \frac{I_O}{1-d}$

3. We note that $I_O = (1-d)I_L$ then we can write: $I_O = (1-d) \frac{I_L}{\Delta i_L} \cdot \Delta i_L$

substituting $\Delta i_L = \frac{1}{L} U_L T_{OFF} \Delta i_L$ for equation above, output current is given by

$$I_O = (1-d) \cdot \frac{1}{ICR} \cdot \frac{1}{L} U_L T_{OFF} \quad (ICR = \frac{\Delta i_L}{I_L})$$

$$I_O = (1-d) \cdot \frac{1}{ICR} \cdot \frac{1}{L} (U_O + U_D - U_{IN}) \frac{1-d}{f}$$

$$I_O = (1-d)^2 \cdot \frac{U_O + U_D - U_{IN}}{ICR \cdot L \cdot f}$$

derive that

$$L = \frac{(1-d)^2 (U_O + U_D - U_{IN})}{ICR \cdot I_O \cdot f}$$

4. The peak current of the inductor is given by

$$I_{PK} = I_L + \frac{1}{2} \Delta i_L$$

$$I_{PK} = I_L + \frac{1}{2} \frac{\Delta i_L}{I_L} \cdot I_L$$

according to $ICR = \frac{\Delta i_L}{I_L}$ derive that

$$I_{PK} = I_L + \frac{1}{2} ICR \cdot I_L$$

Then derive the following equation for peak current of inductor

$$I_{PK} = I_L (1 + \frac{1}{2} ICR)$$

5. Charge stores in C3 during charging up is given by $\Delta Q = I_C \cdot T_{OFF}$

we can write $\Delta Q = (I_L - I_O) \cdot \frac{1-d}{f}$

■ APPLICATION CIRCUIT INFORMATION (Cont.)

6. Output ripple voltage is given by

$$V_{PP} = \Delta U_C + ESR \cdot (I_L - I_O) \quad (\text{ESR: equivalent series resistance of the output capacitor})$$

$$V_{PP} = \frac{\Delta Q}{C} + ESR \cdot (I_L - I_O)$$

Then we give the following example about choosing external components by considering the design parameters.

Design parameters: $U_{IN}=1.5V$ $U_O=2.1V$ $I_O=200mA$ $V_{PP}=100mV$ $f=300KHz$ $ICR=0.2$

Assume U_D and U_S are both 0.3V, the duty ratio is

$$d = \frac{U_O + U_D - U_{IN}}{U_O + U_D - U_S} = \frac{2.1 + 0.3 - 1.5}{2.1 + 0.3 - 0.3} = 0.429$$

In order to generate the desired output current and ICR, the value of inductor should meet the following formula

$$L \leq \frac{(1-d)^2(U_O + U_D - U_{IN})}{ICR \cdot I_O \cdot f} = \frac{(1-0.429)^2(2.1V + 0.3V - 1.5V)}{0.2 \times 0.2A \times 300000HZ} = 24.5\mu H$$

Calculate the average current and the peak current of inductor

$$I_L = \frac{I_O}{1-d} = \frac{0.2A}{1-0.429} = 0.35A$$

$$I_{PK} = I_L \left(1 + \frac{1}{2} ICR\right) = 0.35A \times \left(1 + \frac{1}{2} \times 0.2\right) = 0.385A$$

So, we make a trial of choosing a 22uH inductor that allowable maximum current is larger than 0.385A.

Determine the delta charge stores in C3 during charging up

$$\Delta Q = (I_L - I_O) \cdot \frac{1-d}{f} = (0.35A - 0.2A) \times \frac{1-0.429}{300000HZ} = 0.286\mu C$$

Assume the ESR of C3 is 0.15Ω, determine the value of C3

$$C \geq \frac{\Delta Q}{V_{PP} - ESR \cdot (I_L - I_O)} = \frac{0.286 \times 10^{-6} C}{0.1 - 0.15\Omega \times (0.35A - 0.2A)} = 3.69\mu F$$

Therefore, a Tantalum capacitor with value of 10uF and ESR of 0.15Ω can be used as output capacitor. However, the optimized value should be obtained by experiment.

■ EXTERNAL COMPONENTS

1. Diode (D1)

The diode is the largest source of loss in DC-DC converters. The most important parameters which affect the efficiency are the forward voltage drop U_D and the reverse recovery time. The forward voltage drop creates a loss just by having a voltage across the device while a current flowing through it. The reverse recovery time generates a loss when the diode is reverse biased, and the current appears to actually flow backwards through the diode due to the minority carriers being swept from the P-N junction. A Schottky diode with the following characteristics is recommended:

- *Low forward voltage: $U_D < 0.3V$
- *Fast reverse recovery time/switching speed: $\leq 50nS$
- *Rated current: $> I_{PK}$
- *Reverse voltage: $\geq U_O + U_D$

2. Inductor (L1)

Low inductance values supply higher output current, but also increase the ripple and reduce efficiency. Choose a low DC-resistance inductor to minimize loss. It is necessary to choose an inductor with saturation current greater than the peak current that the inductor will encounter in the application. Saturation occurs when the inductor's magnetic flux density reaches the maximum level the core can support and inductance falls.

3. Capacitor (C1, C2)

The input capacitor C1 improves the efficiency by reducing the power impedance and stabilizing the input current. Select a C1 value according to the impedance of the power supply used. Small Equivalent Series Resistance (ESR) Tantalum or ceramic capacitor with an appropriate value should be suitable.

The output capacitor is used for smoothing the output voltage and sustaining the output voltage when the switch is on. Select an appropriate capacitor depending on the ripple voltage that increases in case of a higher output voltage or a higher load current. The capacitor value should be 10uF minimum. Small ESR should be used to reduce output ripple voltage. However, the best ESR may depend on L, capacitance, wiring and applications (output load). Therefore, fully evaluate ESR under an actual condition to determine the best value.

4. External transistor (Q1 R1 C2)

An enhancement N-channel MOSFET or a bipolar NPN transistor can be used as the external switch transistor.

*Bipolar NPN transistor

The h_{FE} value of NPN transistor and the R1 value determine the driving capacity to increase the output current using a bipolar transistor. 1K Ω is recommended for R1. R1 is selected from the following calculation.

Calculate the necessary base current (I_b) from the bipolar transistor h_{FE} using $I_b = \frac{I_{PK}}{h_{FE}}$

$$R1 = \frac{V_{OUT} - 0.7}{I_b} - \frac{0.4}{|I_{EXTH}|}$$

Since the pulse current flows through the transistor, the exact R_B value should be finely tuned by the experiment. Generally, a small R_B value can increase the output current capability, but the efficiency will decrease due to more energy is used to drive the transistor.

Moreover, a speed up capacitor, C2, should be connected in parallel with R1 to reduce switching loss and improve efficiency. C2 can be calculated by the equation below:

$$C2 \leq \frac{1}{2\pi \times R1 \times f_{OSC} \times 0.7}$$

It is due to the variation in the characteristics of the transistor used. The calculated value should be used as the initial test value and the optimized value should be obtained by the experiment.

*Enhancement MOS FET

For enhancement N-channel MOSFET, since enhancement MOSFET is a voltage driven, it is a more efficient switch than a BJT transistor. However, the MOSFET requires a higher voltage to turn on as compared with BJT transistors. An enhancement N-channel MOSFET can be selected by the following guidelines:

- Input capacitance less than 700pF.
- Low gate threshold voltage.
- Low on-resistance.
- The allowable maximum current of drain should be larger than peak current of inductor.

UTC assumes no responsibility for equipment failures that result from using products at values that exceed, even momentarily, rated values (such as maximum ratings, operating condition ranges, or other parameters) listed in products specifications of any and all UTC products described or contained herein. UTC products are not designed for use in life support appliances, devices or systems where malfunction of these products can be reasonably expected to result in personal injury. Reproduction in whole or in part is prohibited without the prior written consent of the copyright owner. The information presented in this document does not form part of any quotation or contract, is believed to be accurate and reliable and may be changed without notice.