



UA7527

Preliminary

LINEAR INTEGRATED CIRCUIT

POWER FACTOR CONTROLLER

DESCRIPTION

The UTC **UA7527** is a simple and high performance active power factor corrective controller for boost PFC application which operates in the critical conduction mode. The UTC **UA7527** is optimized for electronic ballasts, low power and high density power supplies which require minimum board area reduced component count and low power dissipation. Internal R/C filter eliminates the need for an external R/C filter. Special circuitry has also been added to prevent no load runaway conditions. The output drive clamping circuit limits the overshoot of the power MOSFET gate drive despite the supply voltage. This greatly enhances the system reliability.

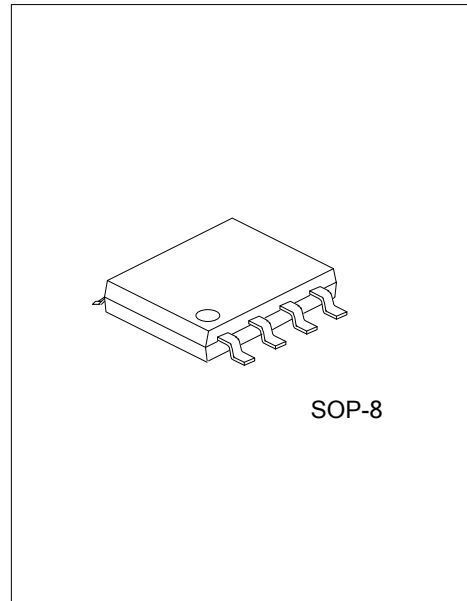

FEATURES

- * Internal Start-up Timer
- * Very Precise Adjustable Output Over Voltage Protection
- * Zero Current Detector
- * Quadrant Multiplier
- * Internal R/C Filter Eliminates the Need for an External R/C Filter
- * Trimmed 1.5% Internal Band Gap Reference
- * Under Voltage Lockout with 3V of Hysteresis
- * Totem Pole Output With High State Clamp
- * Low Start-up and Operating Current

ORDERING INFORMATION

| Ordering Number | | Package | Packing |
|-----------------|---------------|---------|-----------|
| Lead Free | Halogen Free | | |
| UA7527L-S08-R | UA7527G-S08-R | SOP-8 | Tape Reel |
| UA7527L-S08-T | UA7527G-S08-T | SOP-8 | Tube |

| | |
|---|---|
| <p>UA7527L-S08-R</p> <p>(1) Packing Type (2) Package Type (3) Lead Free</p> | <p>(1) R: Tape Reel, T: Tube (2) S08: SOP-8 (3) G: Halogen Free, L: Lead Free</p> |
|---|---|

■ **PIN CONFIGURATION**

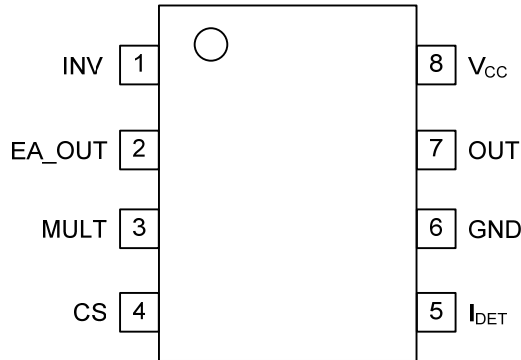

■ **PIN DESCRIPTION**

| PIN NO. | PIN NAME | DESCRIPTION |
|---------|----------|---|
| 1 | INV | The inverting input of the error amplifier. The output of the boost converter should be resistively divided to 2.5V and connected to this pin. |
| 2 | EA_OUT | The error amplifier output. A feedback compensation network is placed between this pin and the INV pin. |
| 3 | MULT | Input to the multiplier stage. Full-wave rectified AC voltage is divided into a voltage less than 2V and is connected to this pin. |
| 4 | CS | Input of the Pulse-Width Modulation comparator. Current is sensed in the boost stage MOSFET by a resistor in the source lead. An internal R / C filter can filter out any high frequency noise. |
| 5 | IDET | Input to zero current detection. |
| 6 | GND | The IC ground. |
| 7 | OUT | Gate driver output. This pin provides an output to an external Power MOSFET with peak current of 500mA. |
| 8 | VCC | The positive supply of the device. |

■ BLOCK DIAGRAM

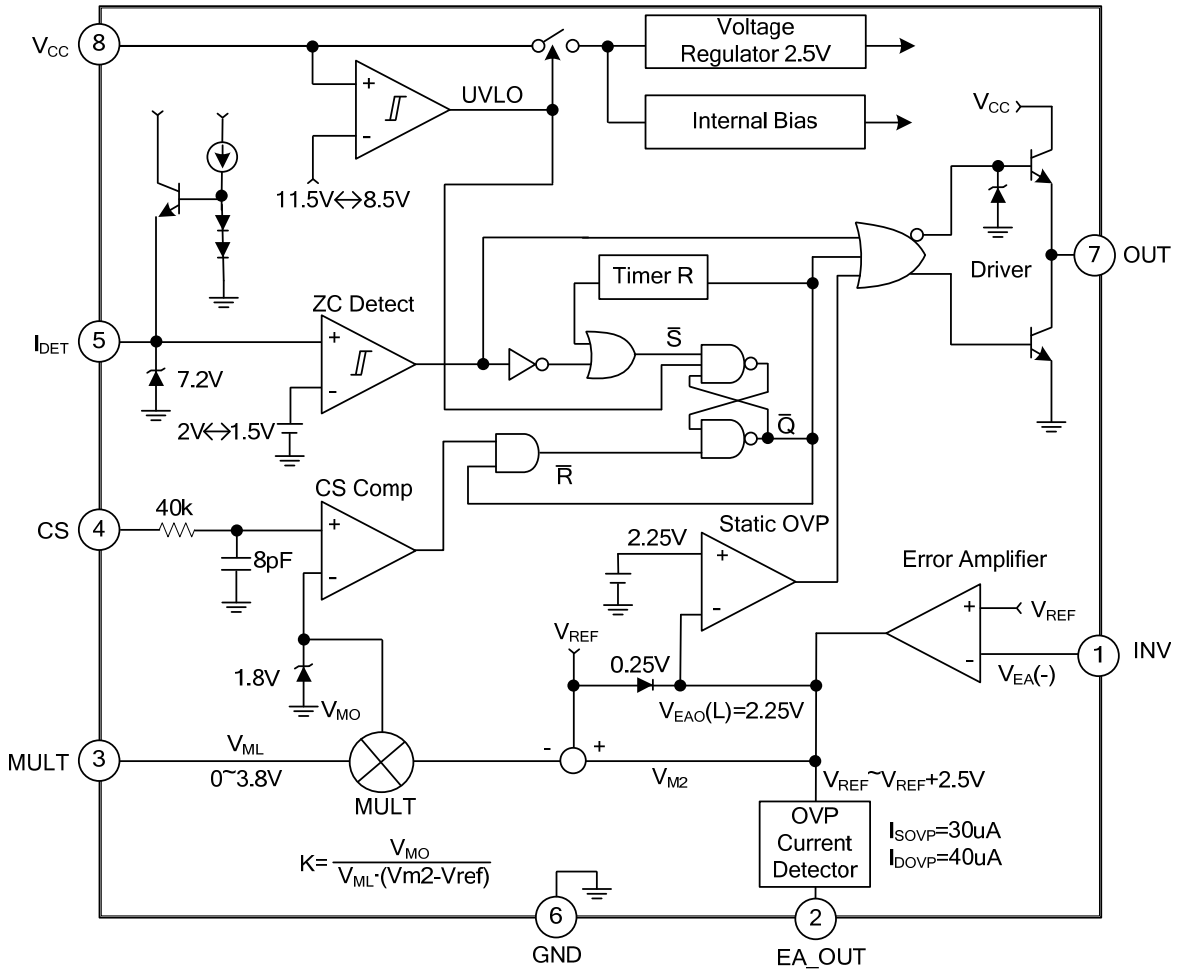

■ **ABSOLUTE MAXIMUM RATING** ($T_A=25^{\circ}\text{C}$, unless otherwise specified)

| PARAMETER | SYMBOL | RATINGS | UNIT |
|---|------------------|-----------|--------------------|
| Supply Voltage | V_{CC} | 30 | V |
| Multiplier, Error Amp and Comparator Input Voltages | V_{IN} | -0.3 ~ 6 | V |
| Peak Drive Output Current | I_{OH}, I_{OL} | ± 500 | mA |
| Output Clamping Diodes Current $V_O > V_{CC}$ or $V_O < -0.3\text{V}$ | I_{CLAMP} | ± 10 | mA |
| Detect Clamping Diodes Current | I_{DET} | ± 10 | mA |
| Power Dissipation | P_D | 0.8 | W |
| Junction Temperature | T_J | 150 | $^{\circ}\text{C}$ |
| Operating Temperature | T_{OPR} | -25 ~ 125 | $^{\circ}\text{C}$ |
| Storage Temperature | T_{STG} | -65 ~ 150 | $^{\circ}\text{C}$ |

Note: Absolute maximum ratings are those values beyond which the device could be permanently damaged. Absolute maximum ratings are stress ratings only and functional device operation is not implied.

■ **TEMPERATURE CHARACTERISTICS** ($-25^{\circ}\text{C} \leq T_A \leq 125^{\circ}\text{C}$)

| PARAMETER | SYMBOL | RATINGS | UNIT |
|---|---------------------|---------|-----------------------|
| Temperature Stability for Reference Voltage (V_{REF}) | ΔV_{REF} | 20 | mV |
| Temperature Stability for Multiplier Gain (K) | $\Delta K/\Delta T$ | -0.2 | $\%/^{\circ}\text{C}$ |

■ **ELECTRICAL CHARACTERISTICS** ($V_{CC}=14\text{V}$, $-25^{\circ}\text{C} \leq T_A \leq 125^{\circ}\text{C}$, unless otherwise specified.)

| PARAMETER | SYMBOL | TEST CONDITIONS | MIN | TYP | MAX | UNIT |
|---|---------------------|---|-----------|------|-----------------|-----------------------|
| UNDER VOLTAGE LOCKOUT SECTION | | | | | | |
| Start Threshold Voltage | $V_{TH(ST)}$ | V_{CC} Increasing | 10.5 | 11.5 | 12.5 | V |
| UV lockout Hysteresis | $HY_{(ST)}$ | | 2 | 3 | 4 | V |
| SUPPLY CURRENT SECTION | | | | | | |
| Start-up Supply Current | I_{ST} | $V_{CC} = V_{TH(ST)} - 0.2\text{V}$ | 10 | 60 | 100 | μA |
| Operating Supply Current | I_{CC} | Output not switching | | 3 | 6 | mA |
| Operating Current at OVP | $I_{CC(OVP)}$ | $V_{INV} = 3\text{V}$ | | 1.7 | 4 | mA |
| Dynamic Operating Supply Current | I_{DCC} | 50kHz, $C_I = 1\text{nF}$ | | 4 | 8 | mA |
| ERROR AMPLIFIER SECTION | | | | | | |
| Voltage Feedback Input Threshold | V_{REF} | $I_{REF} = 0\text{mA}$, $T_A = 25^{\circ}\text{C}$ | 2.465 | 2.5 | 2.535 | V |
| | | $-25 \leq T_A \leq 125^{\circ}\text{C}$ | 2.44 | 2.5 | 2.56 | V |
| Line Regulation | ΔV_{REF1} | $14\text{V} \leq V_{CC} \leq 25\text{V}$ | | 0.1 | 10 | mV |
| Temperature Stability of V_{REF} (Note 1) | ΔV_{REF3} | $-25 \leq T_A \leq 125^{\circ}\text{C}$ | | 20 | | mV |
| Input Bias Current | $I_{B(EA)}$ | | -0.5 | | 0.5 | μA |
| Output Current | I_{SOURCE} | $V_{M2} = 4\text{V}$ | -2 | -4 | | mA |
| | I_{SINK} | $V_{M2} = 4\text{V}$ | 2 | 4 | | mA |
| Output Upper Clamp Voltage (Note 2) | $V_{EA(OH)}$ | $I_{SOURCE} = 0.1\text{mA}$ | | 6 | | V |
| Output Lower Clamp Voltage (Note 3) | $V_{EA(OL)}$ | $I_{SINK} = 0.1\text{mA}$ | | 2.25 | | V |
| Large Signal Open Loop gain (Note 4) | G_V | | 60 | 80 | | dB |
| Power Supply Rejection Ratio (Note 5) | PSRR | $14\text{V} \leq V_{CC} \leq 25\text{V}$ | 60 | 80 | | dB |
| Unity Gain Bandwidth (Note 6) | GBW | | | 1 | | MHz |
| Slew Rate (Note7) | SR | | | 0.6 | | V/ μs |
| MULTIPLIER SECTION | | | | | | |
| Input Bias Current (Pin3) | $I_{B(M)}$ | | -0.5 | | 0.5 | μA |
| M1 Input Voltage Range (Pin3) | ΔV_{M1} | | 0 | | 3.8 | V |
| M2 Input Voltage Range (Pin2) | ΔV_{M2} | | V_{REF} | | $V_{REF} + 2.5$ | V |
| Multiplier Gain (Note8) | K | $V_{M1} = 1\text{V}$, $V_{M2} = 3.5\text{V}$ | 0.36 | 0.44 | 0.52 | 1/V |
| Maximum Multiplier Output Voltage | $V_{OMAX(M)}$ | $V_{INV} = 0\text{V}$, $V_{M1} = 4\text{V}$ | 1.65 | 1.8 | 1.95 | V |
| Multiplier Gain Stability (Note 9) | $\Delta K/\Delta T$ | $-25 \leq T_A \leq 125^{\circ}\text{C}$ | | -0.2 | | $\%/^{\circ}\text{C}$ |

■ **ELECTRICAL CHARACTERISTICS(Cont.)**

| PARAMETER | SYMBOL | TEST CONDITIONS | MIN | TYP | MAX | UNIT |
|--|----------------|--------------------------------|---------------|------|-----|------|
| CURRENT SENSE SECTION | | | | | | |
| Input Offset Voltage (Note 8) | $V_{IO(CS)}$ | $V_{M1}=0V, V_{M2}=2.2V$ | -10 | 3 | 10 | mV |
| Input Bias Current | $I_{B(CS)}$ | $0V \leq V_{CS} \leq 1.7V$ | -1 | -0.1 | 1 | uA |
| Current Sense Delay to Output | $t_{D(CS)}$ | (Note 11) | | 200 | 500 | ns |
| ZERO CURRENT DETECT SECTION | | | | | | |
| Input Voltage Threshold | $V_{TH(DET)}$ | V_{DET} Increasing | 1.7 | 2 | 2.3 | V |
| Detect Hysteresis | $HY_{(DET)}$ | | 0.2 | 0.5 | 0.8 | V |
| Input Low Clamp Voltage | V_{CLAMP} | $I_{DET} = -100\mu A$ | 0.45 | 0.75 | 1 | V |
| Input High Clamp Voltage | V_{CLAMP} | $I_{DET} = 3mA$ | 6.5 | 7.2 | 7.9 | V |
| Input Bias Current | $I_{B(DET)}$ | $1V \leq V_{DET} \leq 5V$ | -1 | -0.1 | 1 | uA |
| Input High/Low Clamp Diode Current | $I_{CLAMP(D)}$ | (Note 12) | | | ±3 | mA |
| OUTPUT SECTION | | | | | | |
| Output Voltage | High | V_{OH} | $I_O = -10mA$ | 10.5 | 11 | V |
| | Low | V_{OL} | $I_O = 10mA$ | | 0.8 | 1 |
| Rising Time (Note 13) | t_R | $C_I = 1nF$ | | 130 | 200 | ns |
| Falling Time (Note 14) | T_F | $C_I = 1nF$ | | 50 | 120 | ns |
| Maximum Output Voltage | $V_{OMAX(O)}$ | $V_{CC} = 20V, I_O = 100\mu A$ | 12 | 14 | 16 | V |
| Output Voltage with UVLO Activated | $V_{OMIN(O)}$ | $V_{CC} = 5V, I_O = 100\mu A$ | | | 1 | V |
| RESTART TIMER SECTION | | | | | | |
| Restart Time Delay | $t_{D(RST)}$ | $V_{M1} = 1V, V_{M2} = 3.5V$ | | 150 | | us |
| OVER VOLTAGE PROTECTION SECTION | | | | | | |
| Soft OVP Detecting Current | I_{SOVP} | | 25 | 30 | 35 | uA |
| Dynamic OVP Detecting Current | I_{DOVP} | | 35 | 40 | 45 | uA |
| Static OVP Threshold Voltage | V_{OVP} | $V_{INV} = 2.7V$ | 2.1 | 2.25 | 2.4 | V |

Notes: 1~14. These parameters, although guaranteed, are not 100% tested in production.

$$\text{Multiplier Gain: } K = \frac{\text{Pin4_Threshold}}{V_{M1} \times (V_{M2} - V_{REF})} \dots\dots (V_{M1}=V_{pin3}, V_{M2}=V_{pin2})$$

■ TYPICAL APPLICATION CIRCUIT

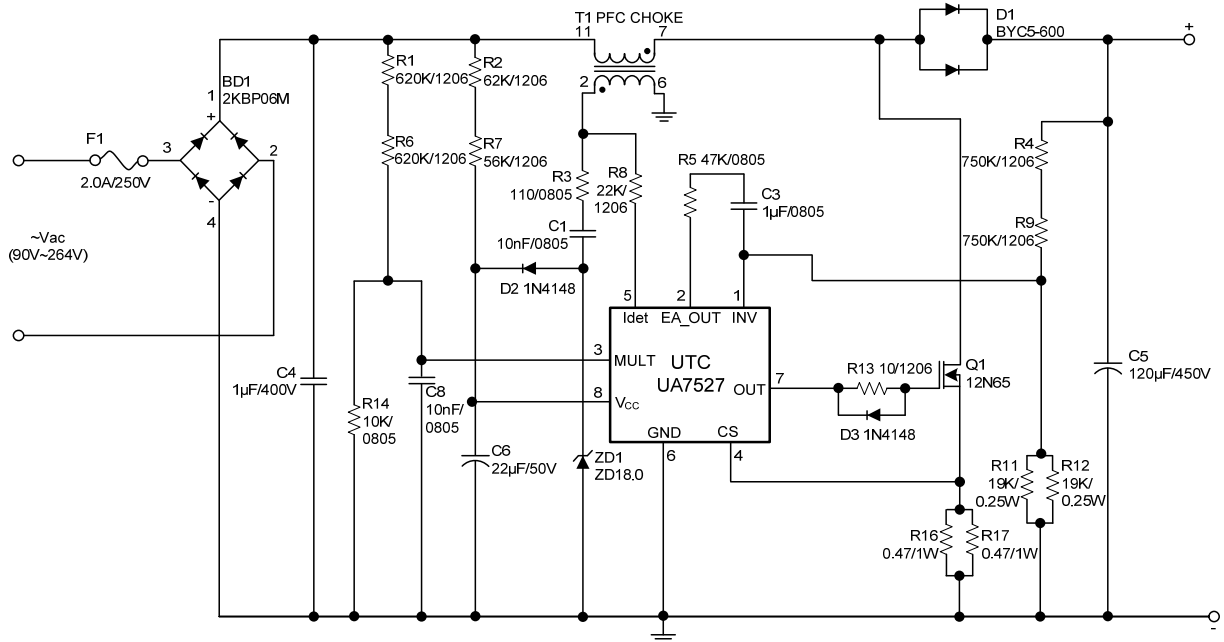

UTC assumes no responsibility for equipment failures that result from using products at values that exceed, even momentarily, rated values (such as maximum ratings, operating condition ranges, or other parameters) listed in products specifications of any and all UTC products described or contained herein. UTC products are not designed for use in life support appliances, devices or systems where malfunction of these products can be reasonably expected to result in personal injury. Reproduction in whole or in part is prohibited without the prior written consent of the copyright owner. The information presented in this document does not form part of any quotation or contract, is believed to be accurate and reliable and may be changed without notice.