



# M7240

CMOS IC

## 3 1/2 LCD DISPLAY DRIVER, A/D CONVERTERS

### DESCRIPTION

The UTC **M7240** is a low voltage power supply of three half A/D conversion IC. With the **M7240**, the product can be assembled the digital gauge outfit and digital multimeters with 3V batteries supply. The **M7240** has here the following features: using the only two batteries of 7V or a 3V lithium batteries can work for long time the chip contains an internal clock generator which can be fine-tuned by a resistor, slicing the band gap in design makes the benchmark signals shift and temperature shift noise greatly improve, slicing the negative power produced within the circuit design, the maximum load current can reach to 2mA.

### FEATURES

- \*Power Supply Voltage:2.5V ~ 6V
- \*external clock circuit within a resistor, used for clock frequency fine-tuning
- \*Built-in close bandgap reference, low temperature drift
- \*High input impedance
- \*Low noise A/D converter
- \*Guaranteed zero reading with zero input.
- \*Has triggered buttons that keep and low voltage alarm function that power
- \*Direct driver LCD display

### ORDERING INFORMATION

Ordering Number		Package	Packing
Lead Free	Halogen Free		
M7240L-QL1-Y	M7240G-QL1-Y	LQFP-44	Tray

<p>M7240L-QL1-Y</p> <p>(1)Packing Type (2)Package Type (3)Lead Free</p>	<p>(1) Y: Tray (2) QL1: LQFP-44 (3) G: Halogen Free, L: Lead Free</p>
---	---

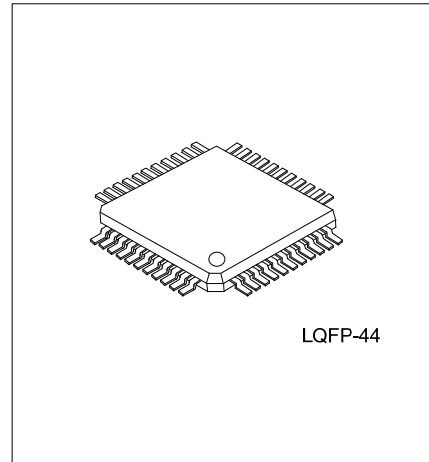

## PIN CONFIGURATIONS

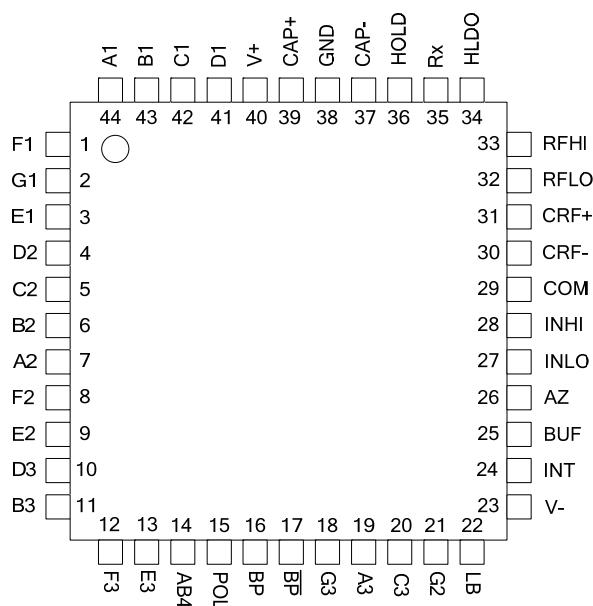

## PIN DESCRIPTION

PIN	NAME	TYPE	PIN DESCRIPTION
1~3、41~44	A1~G1	O	LCD segment drive
4~9、21	A2~G2	O	LCD segment drive
10~13、18~20	A3~G3	O	LCD segment drive
14	AB4	O	LCD segment drive
15	POL	O	LCD Drive display minus "-"
16	BP	O	LCD public driver
17	BP_	O	BP signal output terminals, inverse for LCD display decimal and other special symbols of liquid crystal display driver
22	LB	O	Low battery flag. Pull high if low battery
23	V-	-	Negative voltage
24	INT	-	Integrator output
25	BUF	-	Integration register connection.
26	AZ	-	Auto-zero capacitor connection
27	INLO	I	Analog low input signal
28	INHI	I	Analog high input signal
29	COM	-	Set the common-mode voltage for the system
30	CRF-	-	Negative capacitor connection for on-chip A/D converter
31	CRF+	-	Positive capacitor connection for on-chip A/D converter
32	RFLO	I	Low differential reference input connection.
33	RFHI	I	High differential reference input connection
34	HLDO		Keep output terminal display
35	Rx	-	The clock frequency adjustment, through a resistance to V + adjustable reduce chip clock frequency
36	HOLD		Hold input pin. Connecting to V+ for hold function
37	CAP-		Negative voltage capacitance connection negative terminals
38	GND	I	Ground
39	CAP+		Negative voltage capacitance connection positive terminals
40	V+	I	Positive supply voltage.

■ BLOCK DIAGRAM

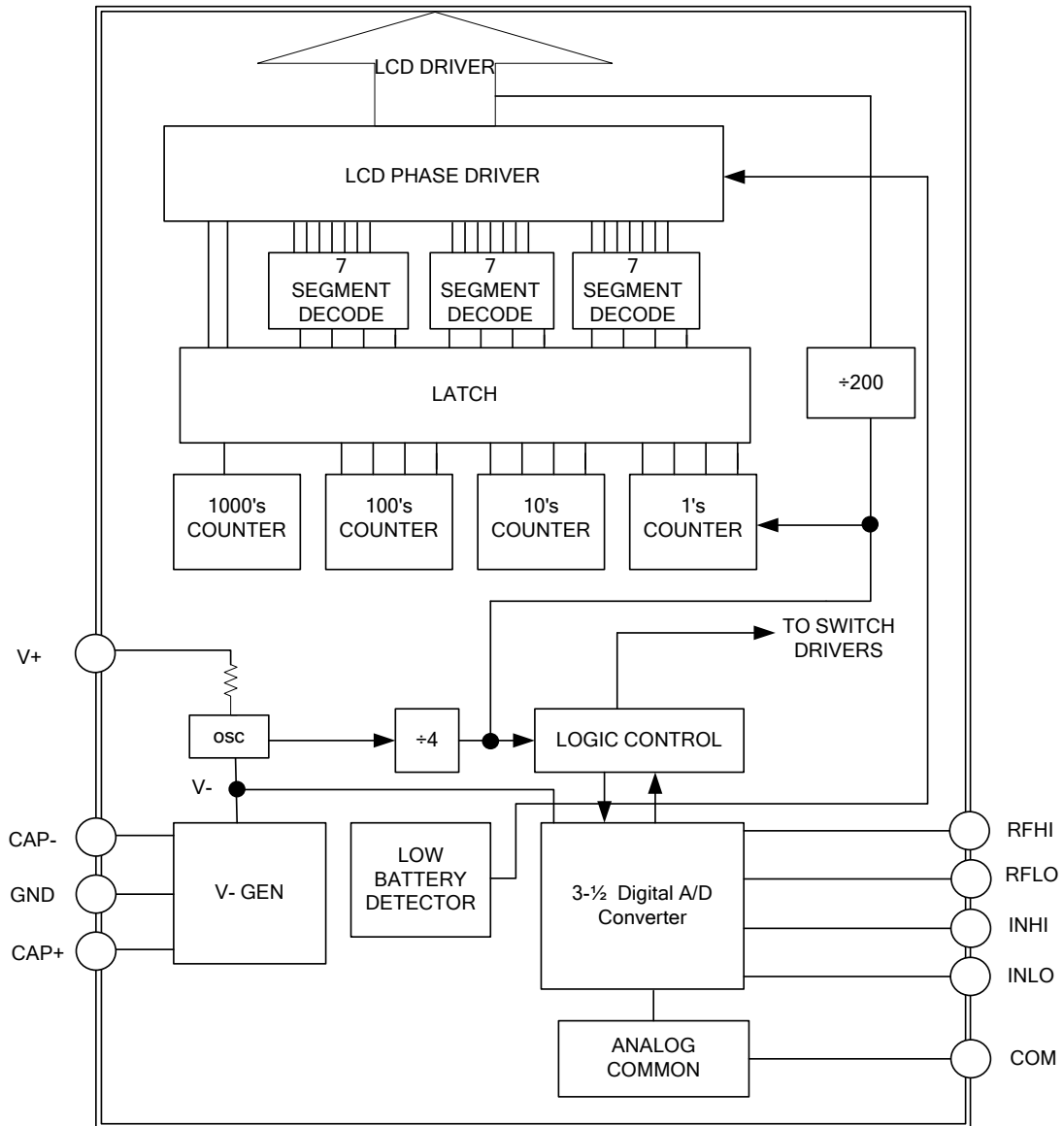

■ **ABSOLUTE MAXIMUM RATING** (unless otherwise specified)

PARAMETER	SYMBOL	RATINGS	UNIT
Power Supply Voltage(V+~V-)	V <sub>CC</sub>	7	V
Analog input voltage	V <sub>IANG</sub>	V+~V-	V
Reference Input Voltage	V <sub>IREF</sub>	V+~V-	V
Operating Temperature	T <sub>OPR</sub>	0 ~ 70	°C
Storage Temperature	T <sub>STG</sub>	-65 ~ +150	°C
Junction Temperature	T <sub>J</sub>	150	°C

Note: Absolute maximum ratings are those values beyond which the device could be permanently damaged.

Absolute maximum ratings are stress ratings only and functional device operation is not implied.

■ **RECOMMENDED OPERATING CONDITIONS** (unless otherwise specified)

PARAMETER	SYMBOL	MIN	TYP	MAX	UNIT
Power Supply Voltage	V <sub>CC</sub>	2.5	3	6	V

■ **ELECTRICAL CHARACTERISTICS** (V<sub>CC</sub>=3V, T<sub>A</sub>=25°C, unless otherwise specified)

PARAMETER	SYMBOL	TEST CONDITIONS	MIN	TYP	MAX	UNIT
V <sub>CC</sub> Range	V <sub>CC</sub>		2.5	3	6	V
Supply Current (Does not include COMMON current )	I <sub>CC</sub>	V <sub>IN</sub> =0V		0.2	0.5	mA
DC characteristics Zero Input Reading	R <sub>Z</sub>	V <sub>IN</sub> =0V,full-scale=200mV	0	0	0	Digital Reading
Ratio metric Reading	R <sub>R</sub>	V <sub>IN</sub> =V <sub>REF</sub> , V <sub>REF</sub> =100mV	999	1000	1001	Digital Reading
Linearity (MAX deviation form best straight line fit)	L	full-scale=200.0mV or full-scale=2.0V	-1	± 0.2	+1	Counts
Rollover Error	E <sub>R</sub>	-V <sub>IN</sub> =+V <sub>IN</sub> ~200mV	-1	± 0.2	+1	Counts
Leakage Current Input	I <sub>L</sub>	V <sub>IH</sub> =0V		1	10	PA
Low battery flag		V+ to V-	2.5	2.6	2.7	V
Analog Common Voltage ( with respect to V+ )	V <sub>COM</sub>	25kΩ Between Common and Positive Supply	2.4	2.5	2.6	V

■ TYPICAL APPLICATIONS CIRCUITS

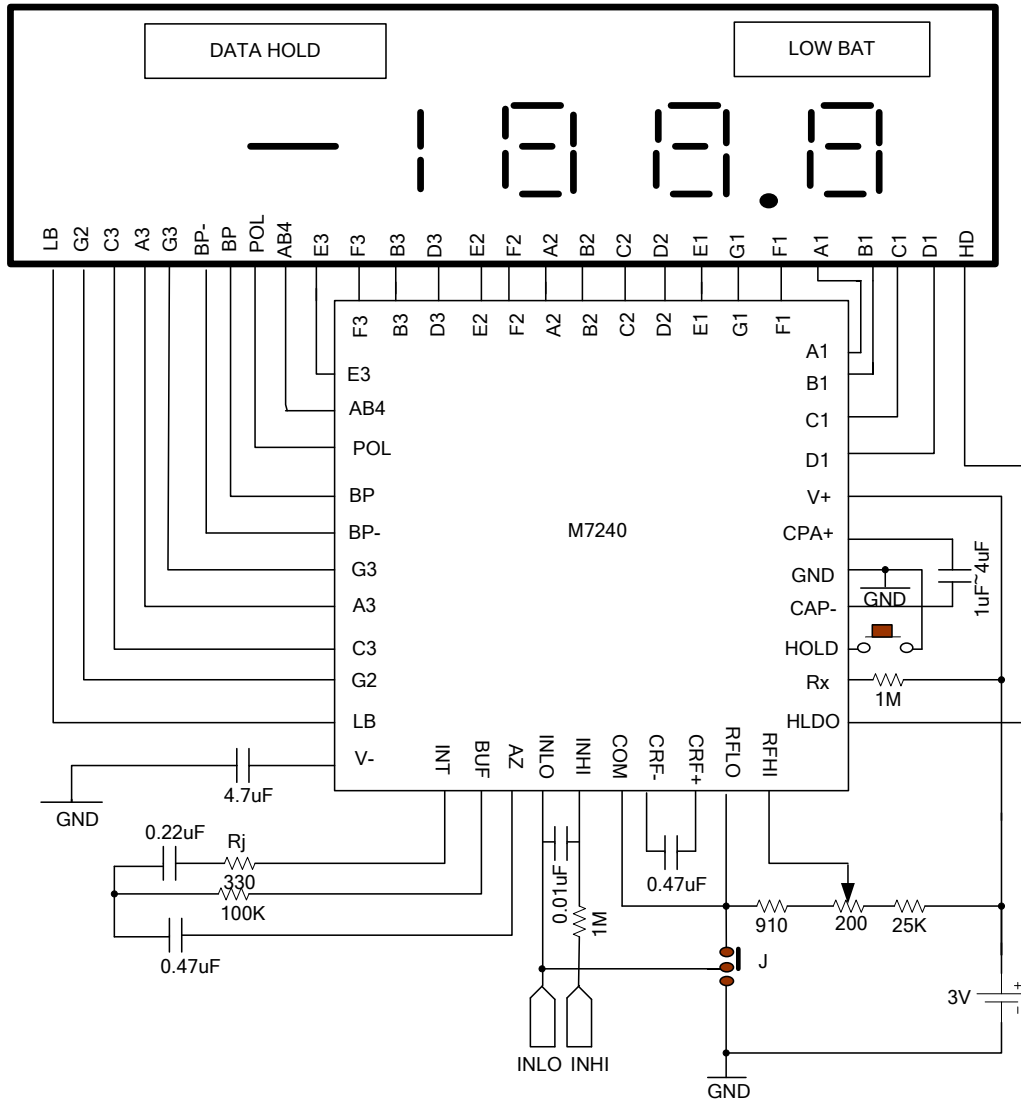

Fig.1

Note :  $R_j$  is a zero resistance, proper value can eliminate zero salvage value.

## ■ APPLICATION INFORMATION

The **M7240** is the production of the basic application of LCD digital DC voltage meter and digital multimeter, by selecting different parameters of the external components, you can create different range gauge outfit. The 200mV range gauge outfit which the most widely used because it is three and a half the basic components of digital multimeter. As **M7240** of 3V low-voltage power supply, making use **M7240** production of the digital DC voltage meter input signal can be a total of COM and common GND two access methods, Figure 1 is the 200mv typical application circuit.

In Fig.1 circuit, when moving the jumper J is connected to INLO and COM, the composition of the input signal connected in COM, when moving the jumper J is connected to INLO and GND, the composition of the input signal connected in GND, for the production of digital multimeter, two input signal connection method in general to meet the application requirements. Use the COM method to make the gauge outfit digital multimeter, the circuit is relatively simple form, but because of COM client can tolerate a few mA maximum current, the need for greater measurement poured into the current project, not applicable. Use the GND method to make the gauge outfit produced digital multimeter, there is no current problem of affordability, but measurement converter circuit is slightly changed.

In addition, if you live in the city to use electricity for 60HZ, in order to reduce the frequency of the circuit city electrical effects, the connection between the RX and power resistors, please use 680KΩ.

## ANALOG COMMON

The COM pin is used to set the common-mode voltage for the system in which the input signals are floating with respect to the power supply of the **M7240**. In most of the applications, INLO, RFLO and COM pins are tied to the same point, so that the common mode voltage can be removed from the reference system and the converter.

The COM pin is also used as a voltage reference. It sets a voltage of around 2.5 volts more negative than the positive supply.

The analog COM is tied internally to an NMOS capable of sinking 30mA. This NMOS will hold the COM voltage at 2.5 volts when an external load attempts to pull the COM voltage toward the positive supply.

The source current of COM is only 10μA, so it is easy to pull COM voltage to a more negative voltage with respect to the positive supply.

## REFERENCE VOLTAGE

For a 1000 counts reading, the input signal must be equal to the reference voltage. As a result, it requires the input signal be twice the reference voltage for a 2000 counts full-scale reading. Thus, for the 200.0mV and 2.000V full-scale, the reference voltage should equal 100.0mV and 1.000V. In some applications the full-scale input voltage may be other than 200mV or 2V, but 600mV. For example, the reference voltage should be set to 300mV and the input signal can be used directly without being divided.

The differential reference can be used during the measurement of resistor by the ratio metric method and when a digital reading of zero is desired for  $V_{in} \neq 0$ . A compensating offset voltage can be applied between COM and INLO and the voltage of being measured is connected between COM and INHI.

## AUTO-ZERO PHASE

During auto-zero three things happen. First, input high and low are disconnected from the pins and internally shorted to analog COM. Second, the reference capacitor is charged to the reference voltage. Third, a feedback loop is closed around the system to charge the auto-zero capacitor  $C_{AZ}$  to compensate for offset voltages in the buffer amplifier, integrator, and comparator. Since the comparator is included in the loop, the AZ accuracy is limited only by the noise of the system. In any case, the offset referred to the input is less than 10μV.

## SIGNAL INTEGRATE PHASE

During signal integrate phase, the auto-zero loop is opened, the internal short is removed, and the internal input high and low are connected to the external pins. The converter then integrates the differential voltage between INHI and INLO for a fixed time. This differential voltage can be within a wide common mode range: up to 1V from either supply. if, on the other hand, the input signal has no return with respect to the converter power supply, INLO can be tied to analog COM to establish the correct common mode voltage. At the end of this phase, the polarity of the integrated signal is determined.

## ■ APPLICATION INFORMATION(Cont.)

### DIFFERENTIAL INPUT

The input can accept differential voltages anywhere within the common mode range of the input amplifier, or specifically from 0.5V below the positive supply to 1V above the negative supply. In this range, the system has a CMRR of 86dB typical. However, care must be exercised to assure the integrator output does not saturate. A worst case condition would be a large positive common mode voltage with a near full scale negative differential input voltage. The negative input signal drives the integrator positive when most of its swing has been used up by the positive common mode voltage. For these critical applications the integrator output swing can be reduced to less than the recommended 2V full scale swing with little loss of accuracy. The integrator output can swing to within 0.3V of either supply without loss of linearity.

### REFERENCE VOLTAGE CAPACITOR

The reference voltage can be generated anywhere within the power supply voltage of the converter. The main source of common mode error is a roll-over voltage caused by the reference capacitor losing or gaining charge to stray capacity on its nodes. If there is a large common mode voltage, the reference capacitor can gain charge (increase voltage) when called up to de-integrate a positive signal but lose charge (decrease voltage) when called up to de-integrate a negative input signal. This difference in reference for positive or negative input voltage will give a roll-over error. However, by selecting the reference capacitor such that it is large enough in comparison to the stray capacitance, this error can be held to less than 0.5 count worst case.

## ■ COMPONENT VALUE SELECTION

### INTEGRATING RESISTOR

Both the buffer amplifier and the integrator have a class A output stage with 100 $\mu$ A of quiescent current. They can supply 4 $\mu$ A of drive current with negligible nonlinearity. The integrating resistor should be large enough to remain in this very linear region over the input voltage range, but small enough that undue leakage requirements are not placed on the PC board. For 2V full scale, 470k $\Omega$  is near optimum and similarly a 100k $\Omega$  for a 200mV scale.

### INTEGRATING CAPACITOR

The integrating capacitor should be selected to give the maximum voltage swing that ensures tolerance buildup will not saturate the integrator swing(approximately. 0.3V from either supply).In the **M7240**, when the analog COMMON is used as a reference, a nominal+2V full scale integrator swing is fine. For three readings/second (48kHz clock) nominal values for C<sub>INT</sub> are 0.22 $\mu$ F and 0.10 $\mu$ F, respectively. Of course, if different oscillator frequencies are used, these values should be changed in inverse proportion to maintain the same output swing.

An additional requirement of the integrating capacitor is that it must have a low dielectric absorption to prevent roll-over errors. While other types of capacitors are adequate for this application, polypropylene capacitors give undetectable errors at reasonable cost.

### AUTO-ZERO CAPACITOR

The size of the auto-zero capacitor has some influence on the noise of the system. For 200mV full scale where noise is very important, a 0.47 $\mu$ F capacitor is recommended. On the 2V scale, a 0.047 $\mu$ F capacitor increases the speed of recovery from overload and is adequate for noise on this scale.

### REFERENCE CAPACITOR

A 0.1 $\mu$ F capacitor gives good results in most applications. However, where a large common mode voltage exists and a 200mV scale is used, a larger value is required to prevent roll-over error. Generally 1 $\mu$ F will hold the roll-over error to 0.5 count in this instance.

UTC assumes no responsibility for equipment failures that result from using products at values that exceed, even momentarily, rated values (such as maximum ratings, operating condition ranges, or other parameters) listed in products specifications of any and all UTC products described or contained herein. UTC products are not designed for use in life support appliances, devices or systems where malfunction of these products can be reasonably expected to result in personal injury. Reproduction in whole or in part is prohibited without the prior written consent of the copyright owner. The information presented in this document does not form part of any quotation or contract, is believed to be accurate and reliable and may be changed without notice.