



# P2583

## LINEAR INTEGRATED CIRCUIT

### 380KHz, 3A STEP-DOWN SWITCHING REGULATOR

#### DESCRIPTION

The UTC **P2583** is a fixed 380kHz frequency, current mode, PWM controller with an internal power MOSFET. It achieves 3A continuous output current over a wide input supply range with excellent load and line regulation. Equipped with an external compensation pin, this device offers user flexibility in determining loop dynamic.

The UTC **P2583** integrates controls, monitoring and protection functions into a single 8-pin package to provide a low cost and perfect power solution. The device provides wide 3.6V to 28V operating input range, also highly efficient with peak operating efficiency at 90%.

An Under-Voltage-Lock-Out (UVLO) circuit monitors the Vin supply voltage to prevent wrong logic controls. An internal 1.222V reference provides low output voltage down to 1.22V for further applications. The controller's over-current protection monitors the output current by using the voltage drop across a current sensing resistor. Additional under voltage protections monitor the voltage on FB pin for short-circuit protections.

The UTC **P2583** provides fast transient respond and requires very few external devices for operation.

#### FEATURES

- \* 3A Output Current
- \*  $V_{in}=3.6V, V_{out}=2.5V, I_{load\_max}$  up to 3A
- \* 380kHz frequency of operation
- \* 3.6V to 28V Input Voltage Range
- \* 25 $\mu$ A Shutdown Supply Current
- \* Output Adjustable from 1.22V to 21V
- \* Frequency FoldBack at Short Circuit
- \* Thermal Shutdown
- \* Under Voltage Lock Output
- \* Current Mode with Low ESR Output Ceramic Capacitors
- \* Up to 90% Efficiency

#### ORDERING INFORMATION

Ordering Number		Package	Packing
Lead Free	Halogen Free		
P2583L-S08-R	P2583G-S08-R	SOP-8	Tape Reel
P2583L-S08-T	P2583G-S08-T	SOP-8	Tube

<p>P2583G-S08-R</p> <p>(1)Packing Type</p> <p>(2)Package Type</p> <p>(3)Halogen Free</p>	<p>(1) R: Tape Reel, T: Tube</p> <p>(2) S08: SOP-8</p> <p>(3) G: Halogen Free, L: Lead Free</p>
--	---

#### PIN CONFIGURATION

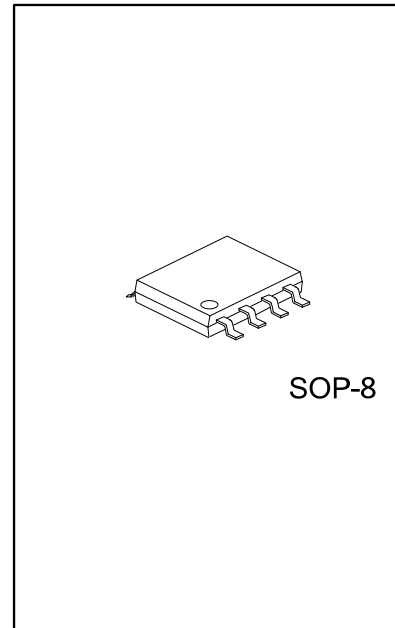

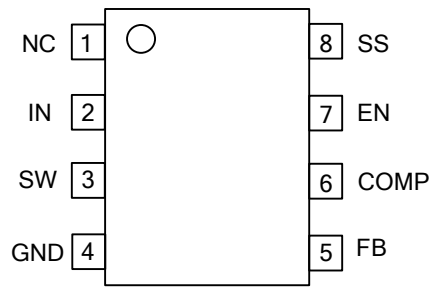

■ **PIN DESCRIPTION**

PIN NO.	PIN NAME	DESCRIPTION
1	NC	NC
2	IN	Power Supply pin.
3	SW	Power Switch Output pin.
4	GND	Ground pin.
5	FB	The output voltage feedback pin. It is also the inverting input of the error amplifier.
6	COMP	Compensation pin. It is also the output of the internal error amplifier. (1). A RC network at this pin compensates the control loop. (2). The voltage at this pin controls the peak current of the internal switch.
7	EN	Regulator On/Off Control pin. Leave EN unconnected if unused. A low input at EN turns on the converter, and a high input turns it off.
8	SS	Soft Start

## ■ BLOCK DIAGRAM

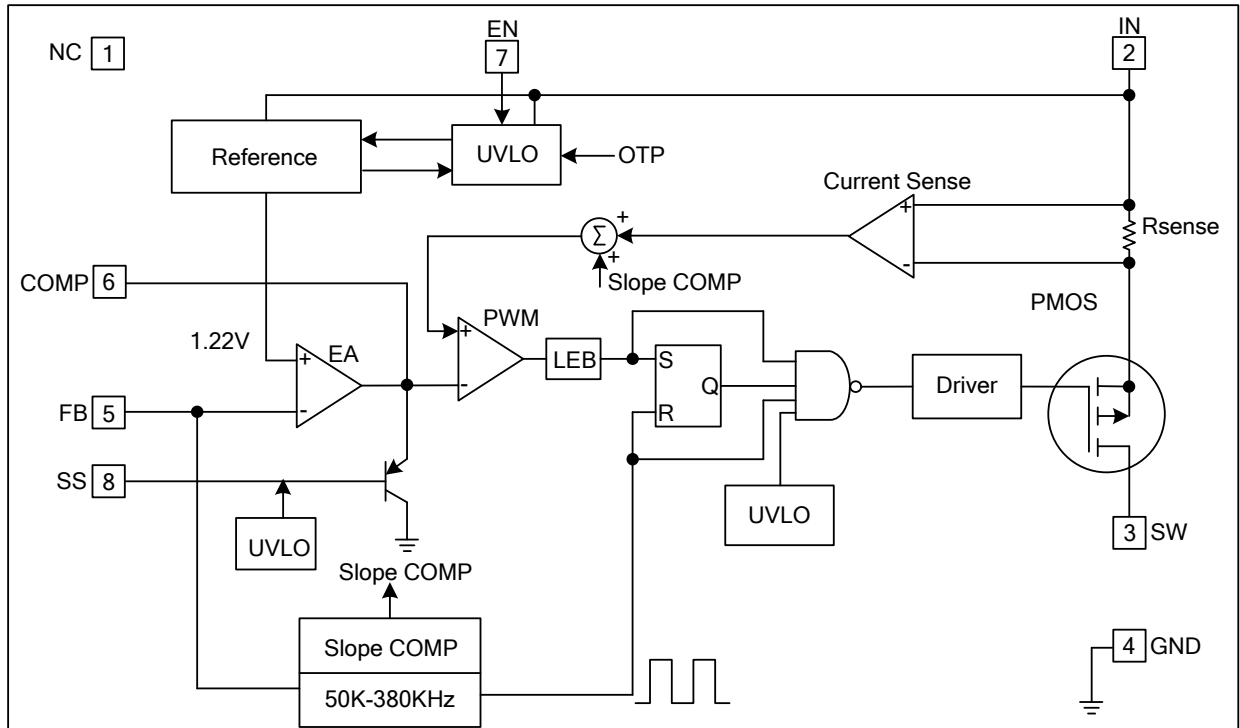

### ■ ABSOLUTE MAXIMUM RATING (Note 2)

PARAMETER	SYMBOL	RATINGS	UNIT
Supply Voltage	$V_{IN}$	28	V
Switch Voltage	$V_{SW}$	$-1 \sim V_{IN}+1$	V
Feedback Voltage	$V_{FB}$	-0.3~6	V
Enable/UVLO Voltage	$V_{EN}$	-0.3~6	V
Comp Voltage	$V_{COMP}$	-0.3~6	V
Sync Voltage	$V_{SYNC}$	-0.3~6	V
Junction Temperature	$T_J$	150	°C
Storage Temperature	$T_{STG}$	-65~+150	°C

Note:1. Absolute maximum ratings are those values beyond which the device could be permanently damaged.

Absolute maximum ratings are stress ratings only and functional device operation is not implied.

2. Exceeding these ratings may damage the device.

### ■ RECOMMENDED OPERATING CONDITIONS (Note 3)

PARAMETER	SYMBOL	RATINGS	UNIT
Input Voltage	$V_{IN}$	3.6~28	V
Ambient Operating Temperature	$T_A$	-40 ~ +125	°C

Note: 3. The device is not guaranteed to function outside its operating rating.

### ■ PACKAGE THERMAL CHARACTERISTICS (Note 4)

PARAMETER	SYMBOL	RATINGS	UNIT
Junction to Ambient	$\theta_{JA}$	105	°C/W
Junction to Case	$\theta_{JC}$	50	°C/W

Note: 4. Measured on approximately 1" square of 1 oz. Copper surrounding device leads.

### ■ ELECTRICAL CHARACTERISTICS (Unless otherwise specified $V_{IN}=12V$ , $T_A=25^\circ C$ )

PARAMETER	SYMBOL	TEST CONDITIONS	MIN	TYP	MAX	UNIT
Feedback Voltage	$V_{FB}$	$4.75V \leq V_{IN} \leq 25V$ , $V_{COMP} < 2V$	1.198	1.222	1.246	V
Switch On Resistance	$R_{SW}$			0.11		$\Omega$
Upper Switch Leakage	$I_{O(OFF)}$	$V_{EN}=0V$ , $V_{SW}=0V$		0	15	$\mu A$
Current Limit	$I_{LIMIT}$		3.3			A
Current Limit Gain. Output Current to Comp Pin Voltage				5.5		A/V
Error Amplifier Transconductance		$\Delta I_C = \pm 10\mu A$	500	800	1100	$\mu A/V$
Oscillator Frequency	F		342	380	418	KHz
Short Circuit Frequency	F	$V_{FB}=0V$	25	50	75	KHz
Maximum Duty Cycle	$D_{MAX}$	$V_{FB}=1.0V$		90		%
Minimum Duty Cycle	$D_{MIN}$	$V_{FB}=1.5V$			0	%
Enable Threshold	$V_{EN}$	$I_{CC} > 100\mu A$		1.2		V
Enable Pull Up Current	$I_{EN}$	$V_{EN}=0V$		1.5		$\mu A$
Supply Current (quiescent)	$I_{CC}$	$V_{EN} \geq 2.6V$ ; $V_{FB}=1.4V$		2.2	3.5	mA
Shutdown Current	$I_{SD}$	$V_{EN}=0V$		20	35	$\mu A$
Thermal Shutdown	T			160		°C

## ■ TYPICAL APPLICATION CIRCUIT

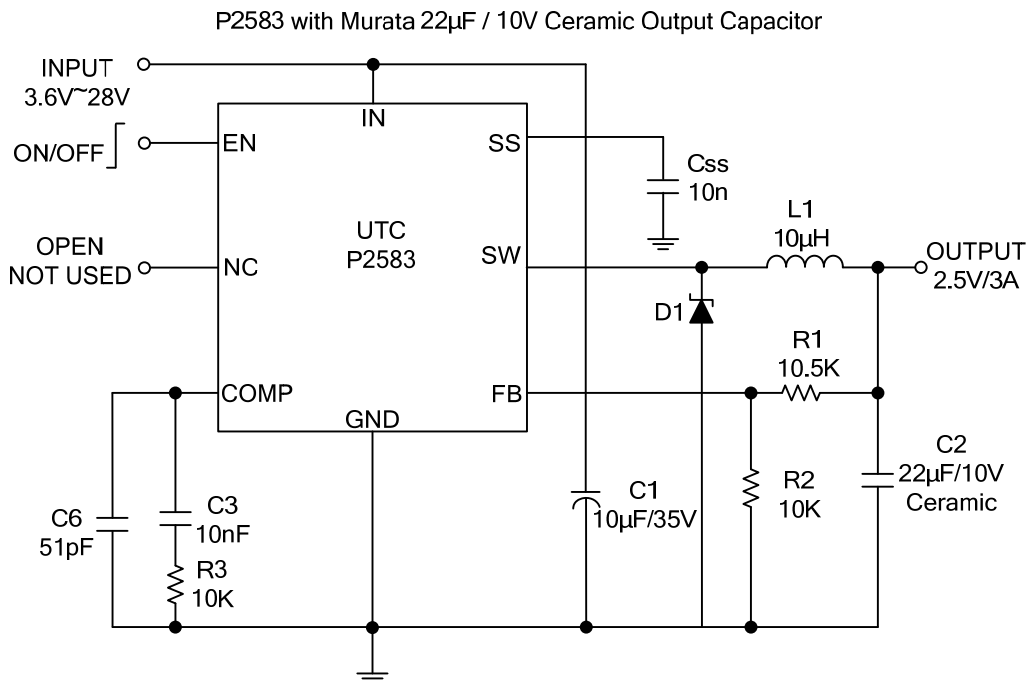
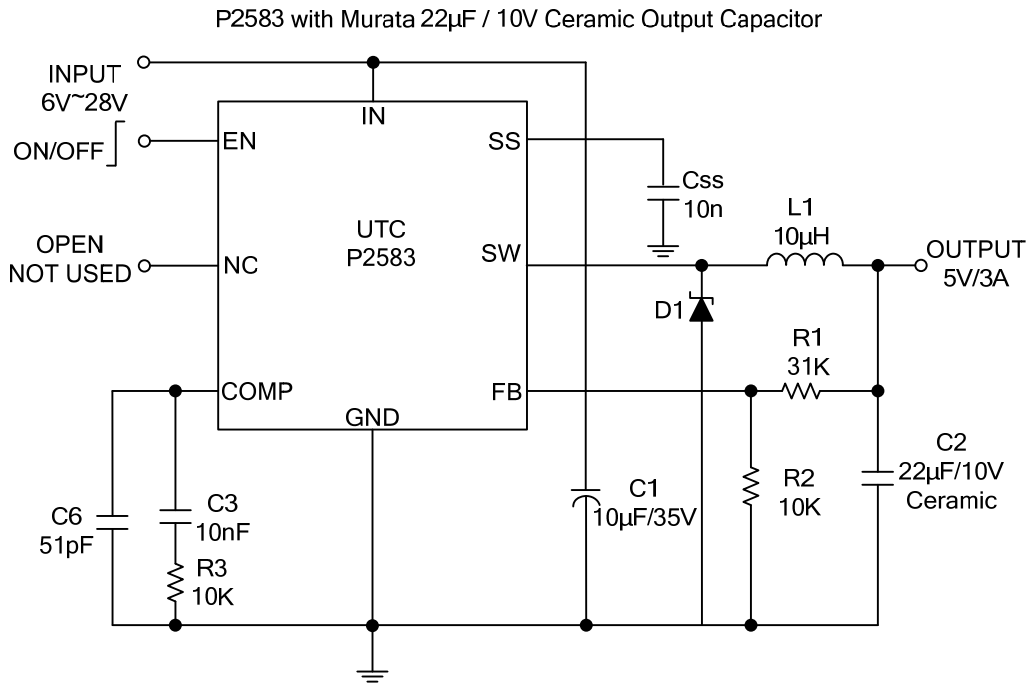

■ TYPICAL CHARACTERISTICS

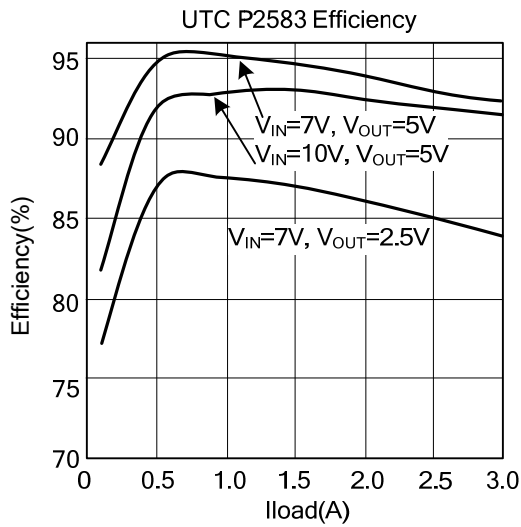

UTC assumes no responsibility for equipment failures that result from using products at values that exceed, even momentarily, rated values (such as maximum ratings, operating condition ranges, or other parameters) listed in products specifications of any and all UTC products described or contained herein. UTC products are not designed for use in life support appliances, devices or systems where malfunction of these products can be reasonably expected to result in personal injury. Reproduction in whole or in part is prohibited without the prior written consent of the copyright owner. The information presented in this document does not form part of any quotation or contract, is believed to be accurate and reliable and may be changed without notice.