



P1686

LINEAR INTEGRATED CIRCUIT

600KHZ, 3A STEP-DOWN CURRENT MDOE SWITCHING REGULATOR

DESCRIPTION

As a current mode switching regulator with an integrated switch, the UTC **P1686** is operating at 600kHz with separate sync and enable functions. In order to avoid frequency beating in noise sensitive applications the sync function allows customers to synchronize to a faster clock. Cost effective low power solutions is considered in the integrated switch ,and so peak switch current 3 amps. Very small passive components is considered in High frequency of operation. Current mode operation: fast dynamic response and instantaneous duty cycle adjustment as the input changes, as a ideal for CPE applications where the input is a wall plug power.

The low shutdown current as ideal for portable applications when battery life is important.

The UTC **P1686** is synchronizable to a frequency from 750kHz to 1.2MHz.

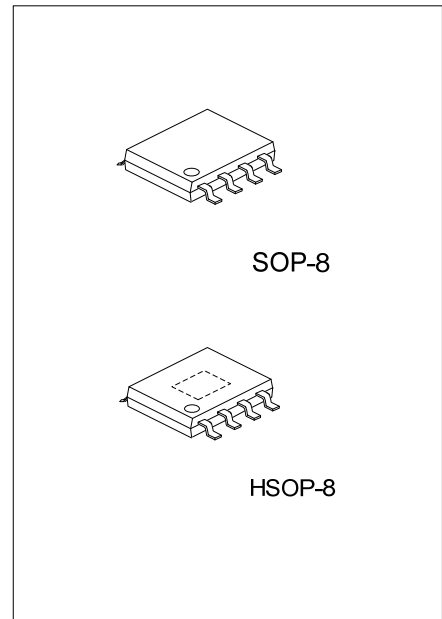

FEATURES

- * Integrated 3 Amp switch
- * 600kHz frequency of operation
- * Current mode controller
- * Synchronizable to higher frequency up to 1.2MHz
- * 6µA low shutdown current

ORDERING INFORMATION

Ordering Number		Package	Packing
Normal	Lead Free Plating		
P1686-S08-R	P1686L-S08-R	SOP-8	Tape Reel
P1686-S08-T	P1686L-S08-T	SOP-8	Tube
P1686-SH2-R	P1686L-SH2-R	HSOP-8	Tape Reel
P1686-SH2-T	P1686L-SH2-T	HSOP-8	Tube

<p>P1686L-S08-R</p> <p>(1)Packing Type (2)Package Type (3)Lead Plating</p>	<p>(1) R: Tape Reel, T: Tube (2) S08: SOP-8, SH2: HSOP-8 (3) L: Lead Free Plating, Blank: Pb/Sn</p>
--	---

■ PIN CONFIGURATION

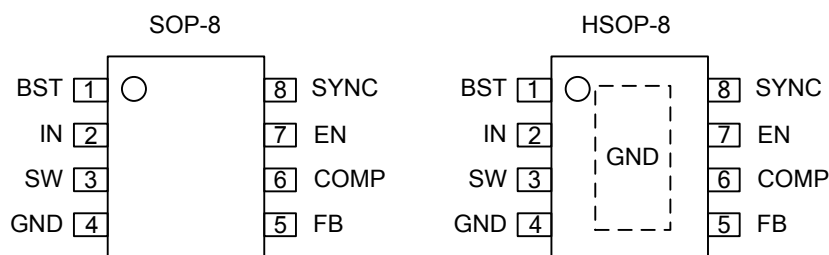

■ PIN DESCRIPTION

PIN NO.	PIN NAME	PIN FUNCTION
1	BST	Providing power to the internal NPN switch. To turn on for this switch the lowest voltage is 2.7V.
2	IN	This PIN delivers all control and power circuitry's power, and sees high di/dt during switching. A decoupling capacitor is better to be attached to this pin very closely.
3	SW	This PIN is the emitter of the internal switch and should be connected with the external freewheeling diode very closely.
4	GND	Almost all voltages are measured with respect to this pin. The decoupling capacitor and the freewheeling diode is better to be connected to this PIN as short as possible.
5	FB	Input of feedback for adjustable output controllers.
6	COMP	Output of the internal error amplifier and also input of the peak current comparator. To achieve the specified performance a compensation network is connected to this pin.
7	EN	Chip enable input. EN is high: the regulator switched on; EN is low: off. EN is low: the regulator is in standby mode, and the input supply current is reduced to a few microamperes.
8	SYNC	Synchronous control pin used to synchronize the internal oscillator to an external pulse control signal. But it should be connected to GND when not used.

■ BLOCK DIAGRAM

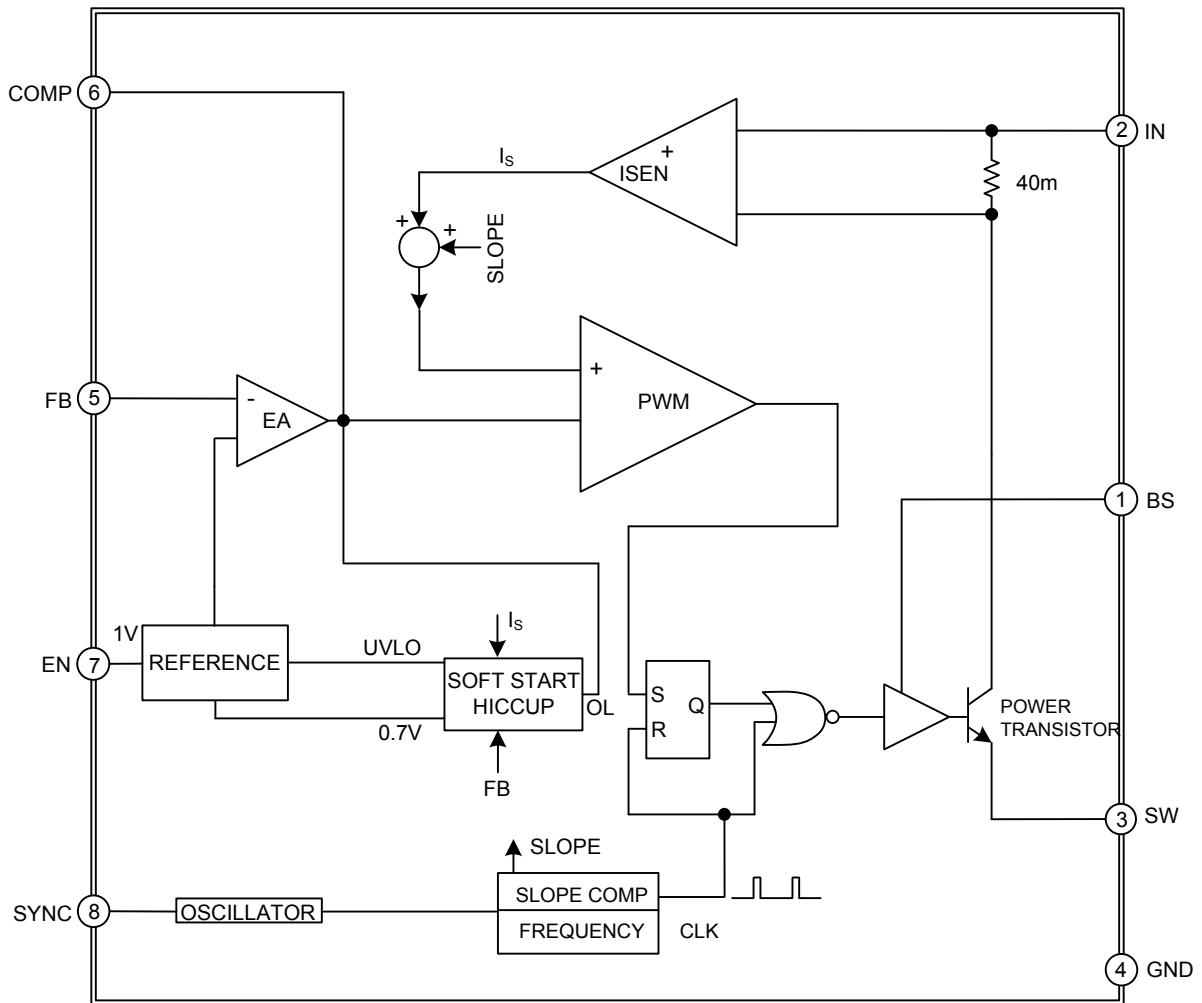

■ ABSOLUTE MAXIMUM RATINGS

PARAMETER	SYMBOL	RATINGS	UNITS
Input Supply Voltage	V_{IN}	-0.3 ~ +28	V
Boost Pin Above V_{SW}	$(V_{BST} - V_{SW})$	16	V
Boost Pin Voltage	V_{BST}	-0.3 ~ +32	V
EN Pin Voltage	V_{EN}	-0.3 ~ +16	V
FB Pin Voltage	V_{FB}	-0.3 ~ +6	V
FB Pin Current	I_{FB}	1	mA
SYNC Pin Current	I_{SYNC}	1	mA
Junction Temperature	T_J	150	°C
Operating Temperature	T_{OPR}	-40 ~ +85	°C
Storage Temperature	T_{STG}	-65 ~ +150	°C

Note: Absolute maximum ratings are those values beyond which the device could be permanently damaged.

Absolute maximum ratings are stress ratings only and functional device operation is not implied.

■ THERMAL DATA

PARAMETER	SYMBOL	RATINGS	UNITS
Junction to Ambient	θ_{JA}	36.5	°C/W

■ ELECTRICAL CHARACTERISTICS

($V_{IN} = 12V$, $V_{COMP} = 0.8V$, $V_{BS} = V_{IN} + 5V$, EN = tied to V_{IN} , SYNC = 0, SW = open. $T_A = T_J = -40^{\circ}C \sim 85^{\circ}C$.)

PARAMETER	SYMBOL	TEST CONDITIONS	MIN	TYP	MAX	UNITS
Operating Input Voltage (Note 1)	V_{IN}				16	V
Maximum Switch Current Limit	I_{SW}			3.0		A
Oscillator Frequency	f_{OSC}		550	600	750	kHz
Switch On Voltage Drop	$V_{D(SW)}$	$I_{SW} = 3A$		330		mV
V_{IN} Undervoltage Lockout	V_{UVLO}	$T_A = 25^{\circ}C$		2.60	3	V
V_{IN} Supply Current	I_Q	$V_{FB} = V_{OUT(NOM)} + 17\%$		1.0	5	mA
Standby Current	$I_{Q(OFF)}$	$V_{EN} = 0V$, $V_{IN} = V_{BOOST} = 16V$, $V_{SW} = 0V$		5	45	μA
FB Input Current	I_{FB}			-0.25	-0.50	μA
Feedback Voltage			1.176	1.2	1.224	V
Feedback Voltage Line Regulation		$3V < V_{IN} < 16V$ (Note 2)		+3		mV/V
FB to V_{COMP} Voltage Gain (Note 3)		$0.4V \leq V_{COMP} \leq 0.9V$	150	350		
FB to V_{COMP} Transconductance (Note 3)		$\Delta I_{COMP} = \pm 10\mu A$	500	850	1300	μMho
V_{COMP} Pin Source Current		$V_{FB} = V_{OUT(NOM)} - 17\%$		70	110	μA
V_{COMP} Pin Sink Current		$V_{FB} = V_{OUT(NOM)} + 17\%$		70	110	μA
V_{COMP} Pin to Switch Current Trans conductance				2.5		A/V
V_{COMP} Pin Maximum Switching Threshold		Duty cycle = 0%		0.35		V
V_{COMP} Pin Threshold		$I_{SW} = 3A$		0.9		V
Maximum Switch Duty Cycle		$V_{COMP} = 1.2V$, $I_{SW} = 400mA$	85			%
Minimum Boost Voltage Above Switch (Note 3)	V_{BOOST}	$I_{SW} = 3A$, $0^{\circ}C \leq T_A \leq 85^{\circ}C$ $I_{SW} = 2.5A$, $T_A < 0^{\circ}C$		1.8	2.7	V
Boost Current	I_{BOOST}	$I_{SW} = 1A$		10	15	mA
		$I_{SW} = 3A$, $0^{\circ}C \leq T_A \leq 85^{\circ}C$ $I_{SW} = 2.5A$, $T_A < 0^{\circ}C$		30	45	
Enable Input Threshold Voltage	V_{IH}		3			V
	V_{IL}				0.4	V
Enable Input Bias Current	I_{IL}	EN = 60mV above threshold		2.5		μA
	I_{IH}	EN = 100mV below threshold		5	15	μA
SYNC Threshold Voltage				1.5		V
SYNC Input Frequency (Note 4)			750		1200	kHz
SYNC Pin Resistance		$V_{SYNC} = 0.5V$		20		k Ω

Note: 1. The device may not function properly outside its operating input voltage range.

2. The required minimum input voltage for a regulated output depends on the output voltage and load condition.
3. Guaranteed by design.
4. For SYNC applications, please contact factory.

■ TYPICAL APPLICATION CIRCUIT

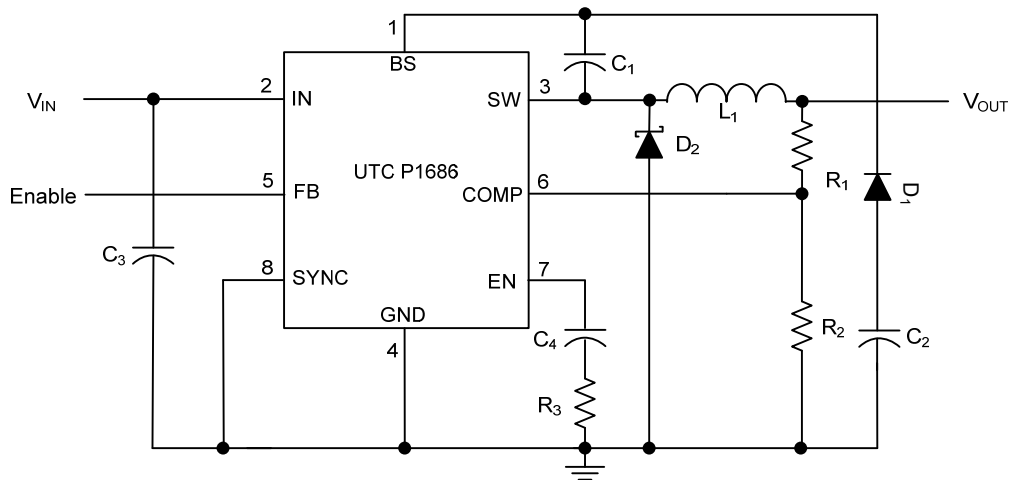

■ APPLICATION CIRCUIT

Design Example: 16V to 5V at 2A

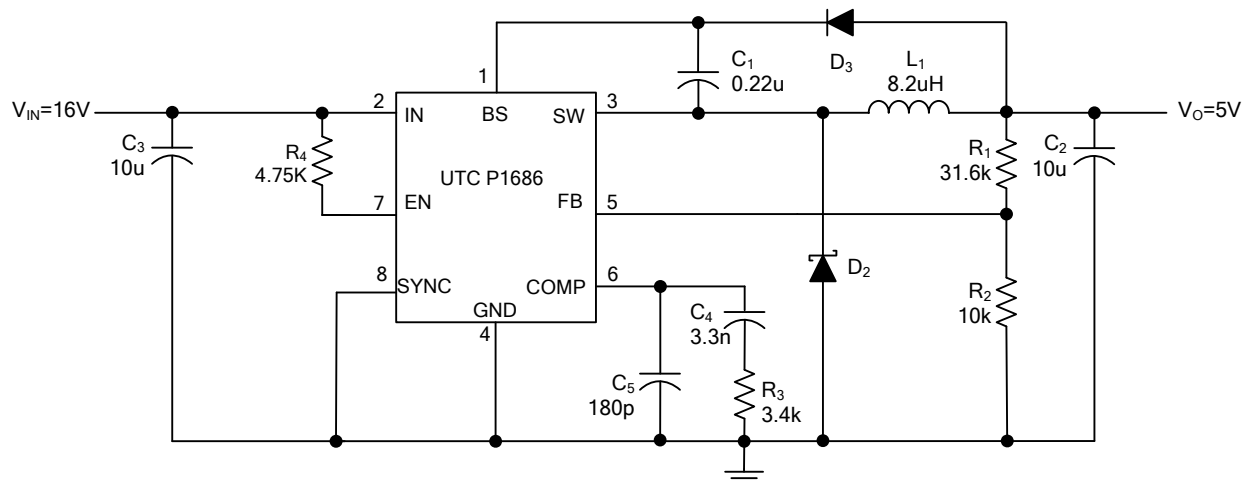

UTC assumes no responsibility for equipment failures that result from using products at values that exceed, even momentarily, rated values (such as maximum ratings, operating condition ranges, or other parameters) listed in products specifications of any and all UTC products described or contained herein. UTC products are not designed for use in life support appliances, devices or systems where malfunction of these products can be reasonably expected to result in personal injury. Reproduction in whole or in part is prohibited without the prior written consent of the copyright owner. The information presented in this document does not form part of any quotation or contract, is believed to be accurate and reliable and may be changed without notice.