



CD4069

CMOS IC

INVERTER CIRCUITS

DESCRIPTION

The UTC **CD4069** consists of six inverter circuits and is manufactured using complementary MOS (CMOS) to achieve wide power supply operating range, low power consumption, high noise immunity, and symmetric controlled rise and fall times.

All inputs are protected from damage due to static discharge by diode clamps to VDD and VSS.

FEATURES

- * Wide supply voltage range: 3.0V ~ 15V.
- * High noise immunity: 0.45 V_{DD} typ.
- * Low Power TTL compatibility: Fan out of 2 driving 74L or 1 driving 74LS.

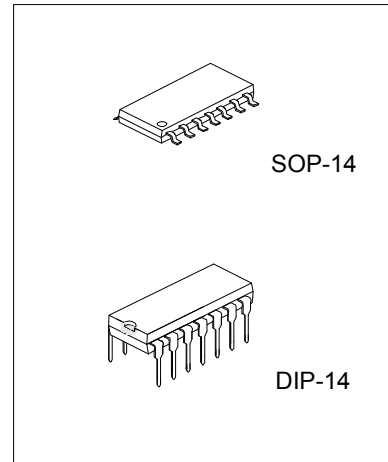

ORDERING INFORMATION

Ordering Number		Package	Packing
Lead Free	Halogen Free		
CD4069L-D14-T	CD4069G-D14-T	DIP-14	Tube
CD4069L-S14-R	CD4069G-S14-R	SOP-14	Tape Reel
CD4069L-S14-T	CD4069G-S14-T	SOP-14	Tube

<p>CD4069L-S14-R</p> <p>(1) Packing Type</p> <p>(2) Package Type</p> <p>(3) Lead Free</p>	<p>(1) R: Tape Reel, T: Tube</p> <p>(2) D14: DIP-14, S14: SOP-14</p> <p>(3) G: Halogen Free, L: Lead Free</p>
---	---

■ PIN CONFIGURATION

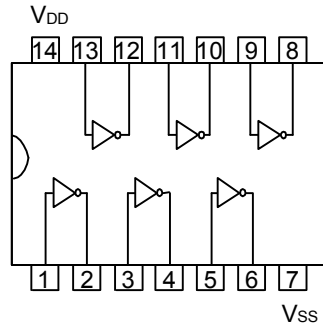

■ BLOCK DIAGRAM

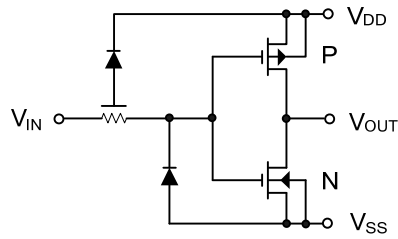

■ ABSOLUTE MAXIMUM RATINGS

PARAMETER	SYMBOL	RATINGS	UNIT
DC Supply Voltage	V_{DD}	-0.5 ~ +18	V
Input Voltage	V_{IN}	-0.5 ~ $V_{DD} + 0.5$	V
Storage Temperature Range	T_S	-65 ~ +150	°C
Power Dissipation	DIP-14	P_D	mW
	SOP-14		
		700	
		500	
Junction Temperature	T_J	125	°C
Operating Temperature	T_{OPR}	-20 ~ +85	°C
Storage Temperature	T_{STG}	-40 ~ +150	°C

Note: Absolute maximum ratings are those values beyond which the device could be permanently damaged.

Absolute maximum ratings are stress ratings only and functional device operation is not implied.

■ RECOMMENDED OPERATING CONDITIONS ($V_{SS}=0V$)

PARAMETER	SYMBOL	RATINGS	UNIT
DC Supply Voltage	V_{DD}	3 ~ 15	V
Input Voltage	V_{IN}	0 ~ V_{DD}	V
Operating Temperature	T_A	-40 ~ 85	°C

■ DC ELECTRICAL CHARACTERISTICS ($V_{SS}=0V$, $T_A=25^\circ C$, unless otherwise specified.)

PARAMETER	SYMBOL	CONDITIONS	MIN	TYP	MAX	UNIT
Quiescent Device Current	I_{DD}	$V_{DD}=5V$, $V_{IN}=V_{DD}$ or V_{SS}			1.0	μA
		$V_{DD}=10V$, $V_{IN}=V_{DD}$ or V_{SS}			2.0	
		$V_{DD}=15V$, $V_{IN}=V_{DD}$ or V_{SS}			4.0	
Low Level Output Voltage	V_{OL}	$ I_O < 1\mu A$	$V_{DD}=5V$	0	0.05	V
			$V_{DD}=10V$	0	0.05	
			$V_{DD}=15V$	0	0.05	
High Level Output Voltage	V_{OH}	$ I_O < 1\mu A$	$V_{DD}=5V$	4.95		V
			$V_{DD}=10V$	9.95		
			$V_{DD}=15V$	14.95		
Low Level Input Voltage	V_{IL}	$ I_O < 1\mu A$	$V_{DD}=5V$, $V_O=4.5V$		1.0	V
			$V_{DD}=10V$, $V_O=9V$		2.0	
			$V_{DD}=15V$, $V_O=13.5V$		3.0	
High Level Input Voltage	V_{IH}	$ I_O < 1\mu A$	$V_{DD}=5V$, $V_O=0.5V$	4.0		V
			$V_{DD}=10V$, $V_O=1V$	8.0		
			$V_{DD}=15V$, $V_O=1.5V$	12.0		
Low Level Output Current (Note 2)	I_{OL}	$V_{DD}=5V$, $V_O=0.4V$	0.44	0.88		mA
		$V_{DD}=10V$, $V_O=0.5V$	1.1	2.25		
		$V_{DD}=15V$, $V_O=1.5V$	3.0	8.8		
High Level Output Current (Note 2)	I_{OH}	$V_{DD}=5V$, $V_O=4.6V$	-0.44	-0.88		mA
		$V_{DD}=10V$, $V_O=9.5V$	-1.1	-2.25		
		$V_{DD}=15V$, $V_O=13.5V$	-3.0	-8.8		
Input Current	I_{IN}	$V_{DD}=15V$, $V_{IN}=0V$		-10^{-5}	-0.30	μA
		$V_{DD}=15V$, $V_{IN}=15V$		10^{-5}	0.30	

■ **AC ELECTRICAL CHARACTERISTICS** (Note 1)

($T_A=25^{\circ}\text{C}$, $C_L=50\text{pF}$, $R_L=200\text{k}\Omega$, t_R and $t_F \leq 20$ ns, unless otherwise specified)

PARAMETER	SYMBOL	CONDITIONS	MIN	TYP	MAX	UNIT
Propagation Delay Time from Input to Output	t_{PHL} or t_{PLH}	$V_{DD}=5\text{V}$		50	90	ns
		$V_{DD}=10\text{V}$		30	60	
		$V_{DD}=15\text{V}$		25	50	
Transition Time	t_{THL} or t_{TLH}	$V_{DD}=5\text{V}$		80	150	ns
		$V_{DD}=10\text{V}$		50	100	
		$V_{DD}=15\text{V}$		40	80	
Average Input Capacitance	C_{IN}	Any Gate		6	15	pF
Power Dissipation Capacitance	C_{PD}	Any Gate (Note 3)		12		pF

Notes: 1. AC Parameters are guaranteed by DC correlated testing.

2. I_{OH} and I_{OL} are tested one output at a time.

3. C_{PD} determines the no load AC power consumption of any CMOS device.

■ AC TEST CIRCUITS AND SWITCHING TIME WAVEFORMS

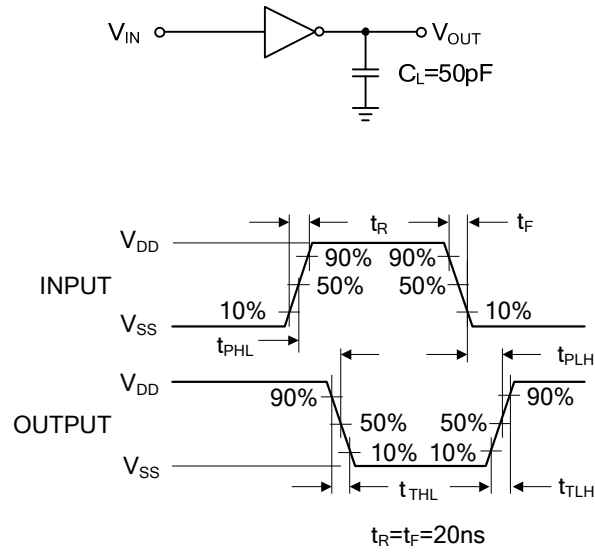

TYPICAL PERFORMANCE CHARACTERISTICS

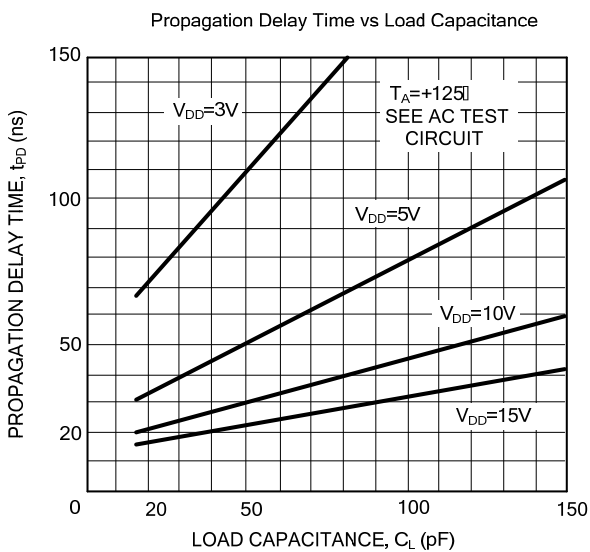
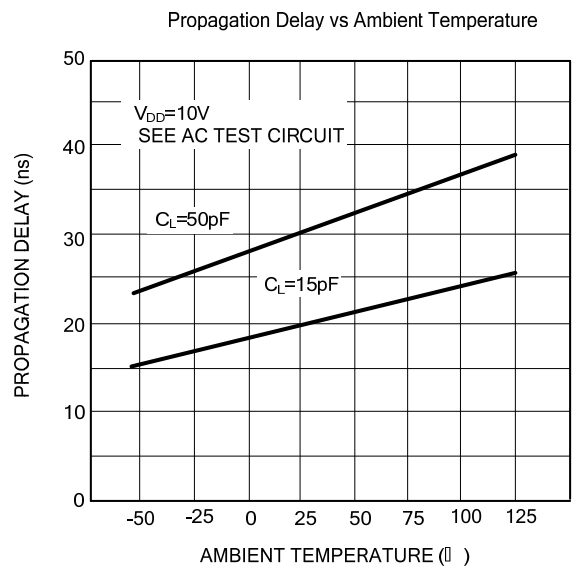
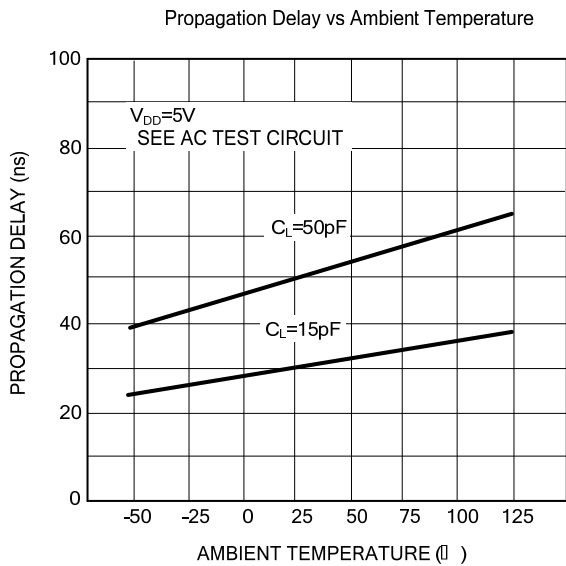
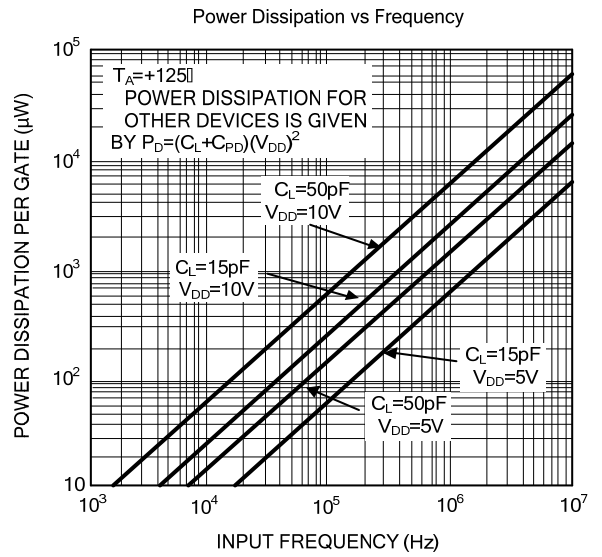
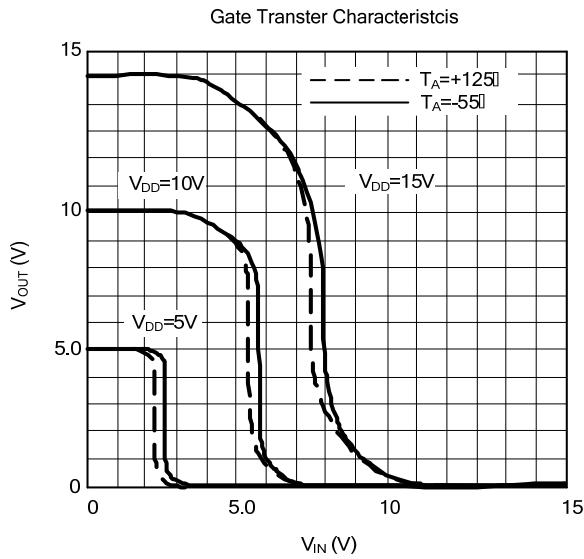

UTC assumes no responsibility for equipment failures that result from using products at values that exceed, even momentarily, rated values (such as maximum ratings, operating condition ranges, or other parameters) listed in products specifications of any and all UTC products described or contained herein. UTC products are not designed for use in life support appliances, devices or systems where malfunction of these products can be reasonably expected to result in personal injury. Reproduction in whole or in part is prohibited without the prior written consent of the copyright owner. The information presented in this document does not form part of any quotation or contract, is believed to be accurate and reliable and may be changed without notice.