

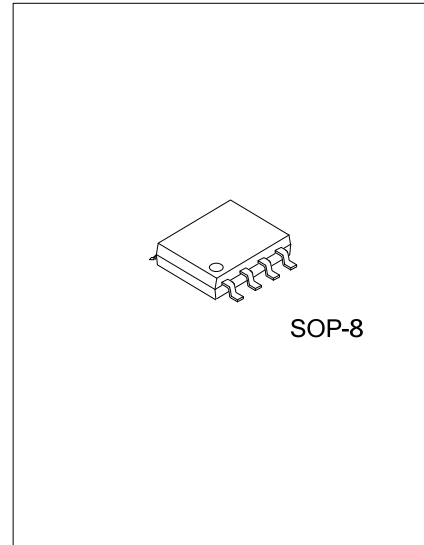

## ADVANCED LINEAR CHARGE MANAGEMENT IC FOR SINGLE AND TWO-CELL LITHIUM-ION AND LITHIUM-POLYMER



### ■ DESCRIPTION

UTC **UB2012** is designed for portable electronics with lower cost. Its advantages of high-accuracy voltage/current regulation, charging status indication, temperature monitoring, and automatic charge-rate compensation.

In applications, the battery temperature is continuously under monitor by using an external thermistor, if the temperature is over user-defined threshold; UTC **UB2012** inhibits charge for safety concern.

Generally, the UTC **UB2012** charges the battery in conditioning, constant voltage and constant current phases. If the battery voltage is lower than the low-voltage threshold ( $V_{MIN}$ ), a low current is used for conditioning the battery. The conditioning charge rate is around 10% of the regulation current and the heat dissipation in the external pass element during the initial stage of the charge is minimized by the conditioning current. After the conditioning phase, the UTC **UB2012** applies a constant current that be set by an external sense-resistor to the battery. The sense-resistor can be on the battery without additional components. The constant current phase continues until the battery reaches the charge-regulation voltage, then the constant voltage phase is beginning.

UTC **UB2012** offers 4.1V, 4.2V, 8.4V and 8.4V fixed-voltage for single and dual cells. Charge stops when the current tapers to the charge termination threshold ( $I_{TERM}$ ) and will recharge if the battery voltage falls below the  $V_{RCH}$ .

The automatic charge-rate compensation feature reduces the charging time of batteries. For the internal impedance of battery pack during charge, this advanced technique offers safe and dynamic compensation.

### ■ FEATURES

- \* Ideal for Single 4.1V, 4.2V and Dual-Cell 8.2V, 8.4V Li-Ion or Li-Pol Packs
- \* 0.3V Dropout Voltage for Minimizing Heat Dissipation
- \* Better than  $\pm 1\%$  Accuracy of Voltage Regulation With Preset Voltages
- \* Dynamic Compensation of Battery Pack's Internal Impedance to short Charging Time
- \* Optional Cell-Temperature Monitoring
- \* Integrated Voltage and Current Regulation With Programmable Charge-Current
- \* Integrated Cell Conditioning for Reviving Deeply Discharged Cells and Minimizing Heat Dissipation During Initial Charge Stage
- \* Charge Status Output for Single or Dual Led or Host Processor Interface
- \* Automatic Battery-Recharge Feature
- \* Charge Termination by Minimum Current
- \* Automatic Low-Power Sleep Mode When  $V_{CC}$  is Removed
- \* EVMs Available for Quick Evaluation

## ORDERING INFORMATION

Ordering Number		Package	Packing
Lead Free	Halogen Free		
UB2012xL-S08-R	UB2012xG-S08-R	SOP-8	Tape Reel
UB2012xL-S08-T	UB2012xG-S08-T	SOP-8	Tube

Note: x: Output Voltage, refer to Marking Information.

<p>UB2012xL-S08-R</p>	<p>(1) R: Tape Reel, T: Tube                  (2) S08: SOP-8                  (3) G: Halogen Free, L: Lead Free                  (4) x: Refer to Marking Information</p>
-----------------------	--

## MARKING INFORMATION

PACKAGE	VOLTAGE CODE	MARKING
SOP-8	A: 4.1V B: 4.2V C: 8.2V D: 8.4V	<p>                         G: Halogen Free                          L: Lead Free                          Voltage Code                          Lot Code                     </p>

## PIN CONFIGURATION

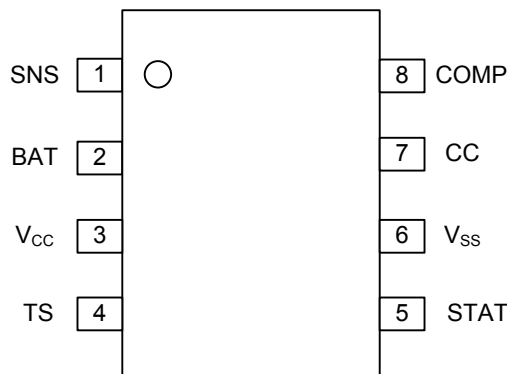

## PIN DESCRIPTION

PIN NO.	PIN NAME	I/O	PIN DESCRIPTION
1	SNS	I	Current sense input
2	BAT	I	Voltage sense input
3	V <sub>CC</sub>	I	Supply voltage
4	TS	I	Temperature sense input
5	STAT	O	Charge status output
6	V <sub>SS</sub>		Ground
7	CC	O	Charge control output
8	COMP	I	Charge-Rate compensation input (Auto Comp)

■ BLOCK DIAGRAM

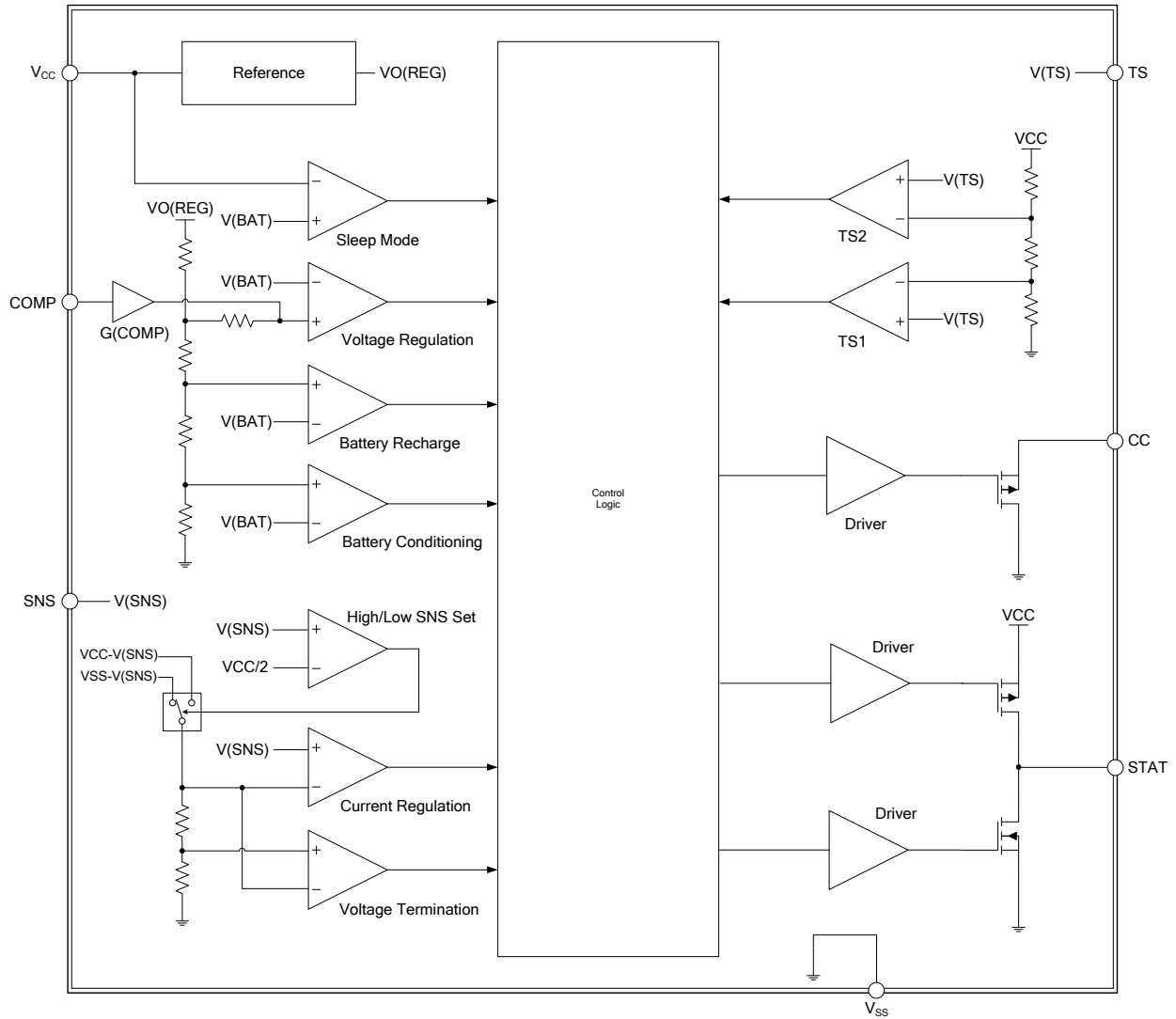

### ■ ABSOLUTE MAXIMUM RATING (unless otherwise specified.)

PARAMETER		SYMBOL	RATINGS	UNIT
Supply Voltage ( $V_{CC}$ with respect to GND)	UB2012A	$V_{CC}$	-0.3 ~ +8.0	V
	UB2012B			
	UB2012C	$V_{CC}$	-0.3 ~ +15	V
	UB2012D			
Input Voltage, SNS, BAT, TS, COMP (all with respect to GND)		$V_{IN}$	-0.3 ~ $V_{CC} + 0.3$	V
Sink Current (Note 2)	STAT pin	$I_{SINK}$	20	mA
Source Current (Note 2)	STAT pin	$I_{SOURCE}$	10	mA
Output Current (Note 2)	CC pin	$I_{OUT}$	40	mA
Power Dissipation ( $T_A=25^\circ\text{C}$ )		$P_D$	300	mW
Operating Temperature		$T_{OPR}$	-20 ~ +85	$^\circ\text{C}$
Storage Temperature		$T_{STG}$	-40 ~ +125	$^\circ\text{C}$

Notes: 1. Absolute maximum ratings are those values beyond which the device could be permanently damaged.

Absolute maximum ratings are stress ratings only and functional device operation is not implied.

2. Not to exceed  $P_D$ .

### ■ RECOMMENDED OPERATING CONDITIONS

PARAMETER		SYMBOL	MIN	TYP	MAX	UNITS
Supply Voltage	UB2012A	$V_{CC}$	4.5		7.0	V
	UB2012B					
	UB2012C	$V_{CC}$	8.6		12	V
	UB2012D					
Operating Free-Air Temperature Range		$T_A$	-20		85	$^\circ\text{C}$

### ■ ELECTRICAL CHARACTERISTICS

PARAMETER	SYMBOL	CONDITIONS	MIN	TYP	MAX	UNITS
$V_{CC}$ Current	$I_{(VCC)}$	$V_{CC} > V_{CC(MIN)}$ , Excluding external loads	UB2012A	2	5	mA
			UB2012B			
			UB2012C	3	7	mA
			UB2012D			
$V_{CC}$ Sleep Current	$I_{(VCCS)}$	$V_{(BAT)} \geq V_{(MIN)}$ $V_{(BAT)} - V_{CC} \geq 0.8\text{V}$	UB2012A	3	6	$\mu\text{A}$
			UB2012B			
			UB2012C	15	$\mu\text{A}$	
			UB2012D			
Input Bias Current	BAT Pin	$I_{IB(BAT)}$	$V_{(BAT)} = V_{(REG)}$		3	$\mu\text{A}$
	SNS Pin	$I_{IB(SNS)}$	$V_{(SNS)} = 5\text{V}$		5	$\mu\text{A}$
	TS Pin	$I_{IB(TS)}$	$V_{(TS)} = 5\text{V}$		5	$\mu\text{A}$
	COMP Pin	$I_{IB(COMP)}$	$V_{(COMP)} = 5\text{V}$		5	$\mu\text{A}$

#### BATTERY VOLTAGE REGULATION

PARAMETER	SYMBOL	CONDITIONS	UB2012A	UB2012B	UB2012C	UB2012D	UNIT
Output Voltage	$V_{O(REG)}$	See Notes	4.050	4.10	4.150	4.250	V
			4.150	4.20	4.300	4.400	V
			8.100	8.20	8.300	8.400	V
			8.300	8.40	8.500	8.600	V

#### CURRENT REGULATION

PARAMETER	SYMBOL	CONDITIONS	UB2012A	UB2012B	UB2012C	UB2012D	UNIT
Current Regulation Threshold	$V_{(SNS)}$	current sensing configuration	UB2012A	80	100	120	mV
			UB2012B				
			UB2012C	90	115	140	mV
			UB2012D				

#### CHARGE TERMINATION DETECTION

PARAMETER	SYMBOL	CONDITIONS	UB2012A	UB2012B	UB2012C	UB2012D	UNIT
Charge Termination Current Detect Threshold	$V_{(TERM)}$	Voltage at pin SNS, $0^\circ\text{C} \leq T_A \leq 50^\circ\text{C}$	-24	-14	-4	-4	mV

### ■ ELECTRICAL CHARACTERISTICS

TEMPERATURE COMPARATOR							
Temperature Threshold	Lower	$V_{(TS1)}$	TS Pin Voltage	29.1	30	30.9	$\%V_{CC}$
	Upper	$V_{(TS2)}$		58.2	60	61.8	$\%V_{CC}$
PRECHARGE COMPARATOR							
Precharge Threshold	$V_{(MIN)}$		UB2012A	2.94	3.0	3.06	V
			UB2012B	3.04	3.1	3.16	V
			UB2012C	5.88	6.0	6.12	V
			UB2012D	6.08	6.2	6.32	V
PRECHARGE CURRENT REGULATION							
Precharge Current Regulation	$V_{(PRECHG)}$	Voltage at pin SNS, $0^{\circ}\text{C} \leq T_A \leq 50^{\circ}\text{C}$			13		mV
		Voltage at pin SNS, $0^{\circ}\text{C} \leq T_A \leq 50^{\circ}\text{C}$ , $V_{CC} = 5\text{V}$		3	13	22	mV
$V_{RCH}$ COMPARATOR (BATTERY RECHARGE THRESHOLD)							
Recharge Threshold	$V_{(RCH)}$		UB2012A	$V_{O(REG)}$	$V_{O(REG)}$	$V_{O(REG)}$	V
			UB2012B	-70mV	-100mV	-130mV	V
			UB2012C	$V_{O(REG)}$	$V_{O(REG)}$	$V_{O(REG)}$	V
			UB2012D	-140mV	-200mV	-260mV	V
CHARGE-RATE COMPENSATION (Automatic Charge-Rate Compensation)							
Automatic Charge-Rate Compensation Gain	$G_{(COMP)}$	$V_{(BAT)} + 0.3\text{V} \leq V_{CC} \leq V_{CC(MAX)}$		1.7	2.2	2.7	V/V
STAT PIN							
Output (Low) Voltage	$V_{OL(STAT)}$	$I_{OL} = 10\text{mA}$				0.7	V
Output (High) Voltage	$V_{OH(STAT)}$	$I_{OH} = 5\text{mA}$		$V_{CC} - 0.5$			V
CC PIN							
Output Low Voltage	$V_{OL(CC)}$	$I_{O(CC)} = 5\text{mA}$ (sink)				1.6	V
Sink Current	$I_{O(CC)}$	Not to exceed power rating ( $P_D$ )		5		40	mA

Note:  $V_{(BAT)} + 0.3\text{V} \leq V_{CC} \leq V_{CC(MAX)}$

■ TYPICAL APPLICATION CIRCUIT

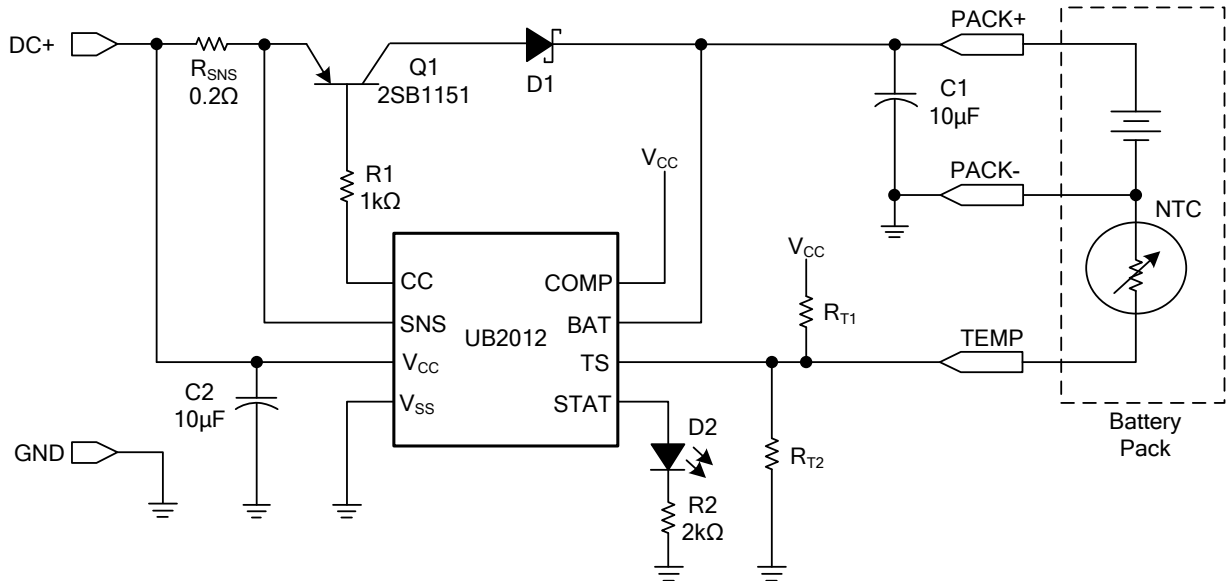

Fig. 1 0.5A Low Dropout Li-Lon/Li-Pol Charger

FUNCTIONAL DESCRIPTION

The UTC **UB2012** is designed for the applications of single or two-cell Li-Ion or Li-Pol batteries. Fig. 1 is the schematic of using this advanced linear charge controller with a PNP pass transistor. Fig. 2 is the operation flowchart of UTC **UB2012**. Fig. 3 shows the typical charge profile. Fig. 4 is the application schematic of a charger using P-channel MOSFET.

APPLICATION INFORMATION

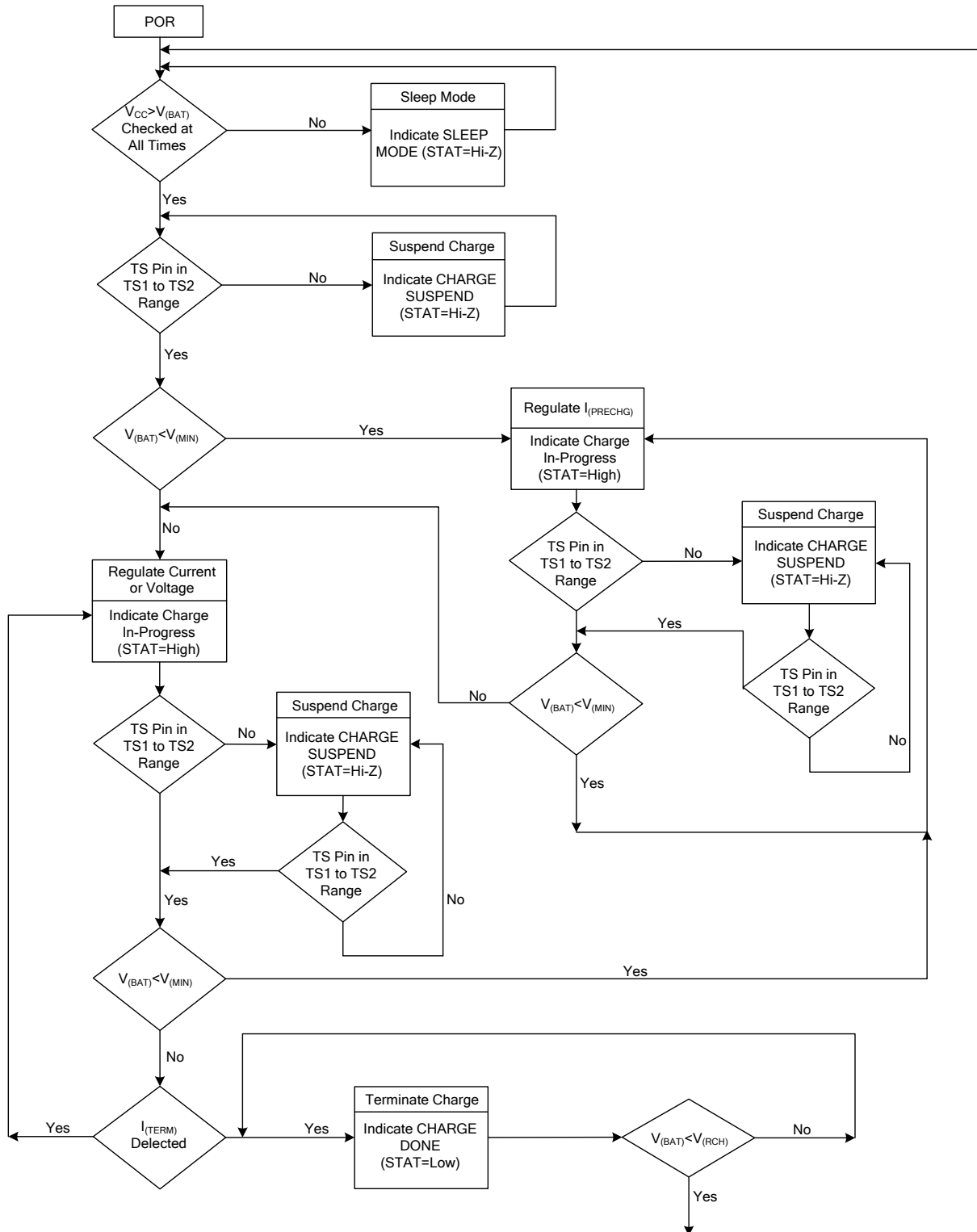

Fig. 2 Operation Flowchart

■ APPLICATION INFORMATION(Cont.)

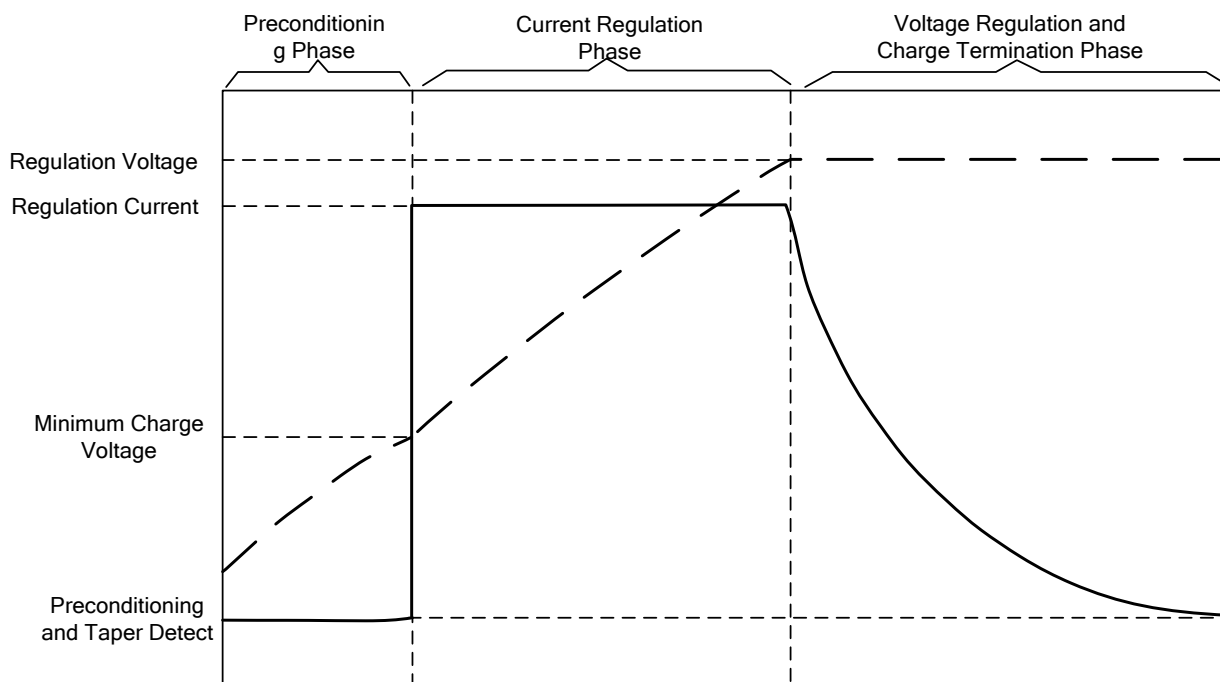

Fig. 3 Typical Charge Profile

QUALIFICATION AND PRECHARGE

When the battery is present and power is applied, the UTC **UB2012** starts a charge-cycle. Charge qualification is affected by battery temperature and voltage. If the battery temperature is out of the  $V_{TS1}$  to  $V_{TS2}$  range; the UTC **UB2012** will suspend charge. In addition, if the battery voltage is below the precharge threshold  $V_{(MIN)}$ , the UTC **UB2012** uses precharge to condition the battery. The conditioning charge rate  $I_{(PRECHG)}$  is set at approximately 10% of the regulation current, and the conditioning current minimizes heat dissipation in the external pass-element during the beginning of charge, refer to Fig. 3.

APPLICATION INFORMATION(Cont.)

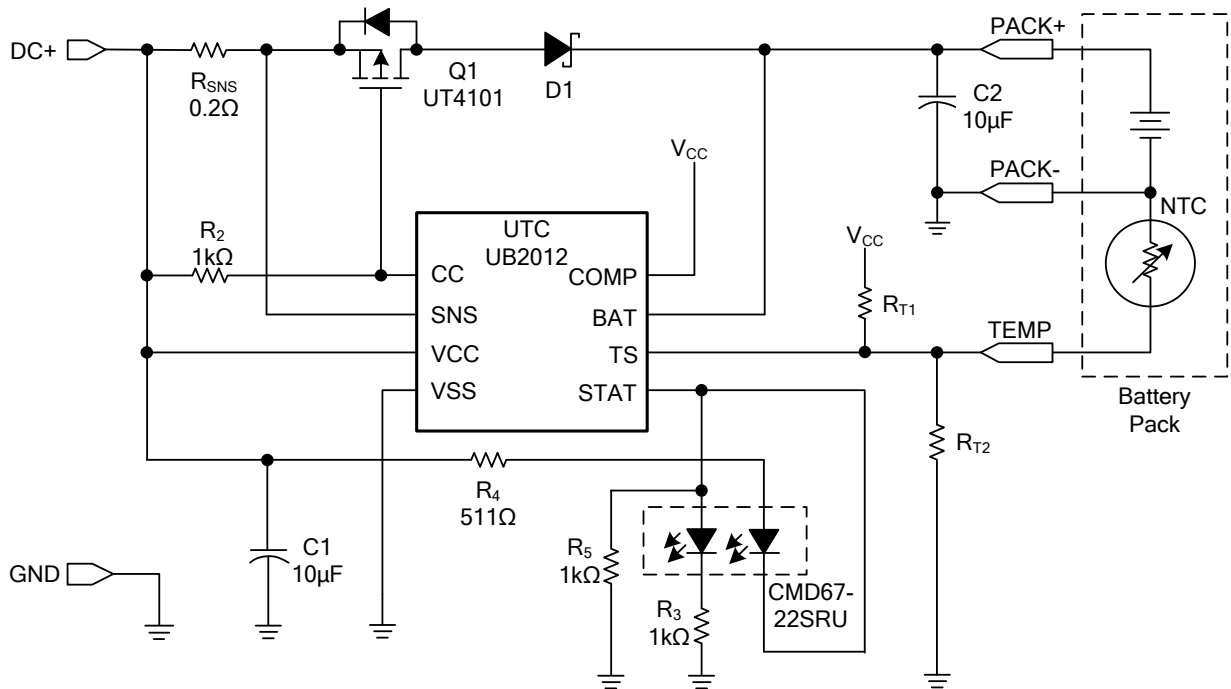

Fig. 4 0.5-A Charger Using P-Channel MOSFET

CURRENT REGULATION PHASE

When the battery-pack voltage is less than the regulation voltage,  $V_{O(REG)}$ , the current is regulated by the UTC UB2012. This advanced linear charge management IC monitors charge current at the SNS input by the voltage drop across a sense-resistor,  $R_{SNS}$ , in series with the battery pack. In current sensing configuration (Fig. 5),  $R_{SNS}$  is between the VCC and SNS pins. Charge-current feedback, applied through pin SNS, maintains a voltage of  $V_{SNS}$  across the current sense resistor. The following formula calculates the value of the sense resistor:

$$R_{SNS} = \frac{V_{(SNS)}}{I_{O(REG)}} \tag{1}$$

Where  $I_{O(REG)}$  is the desired charging current.

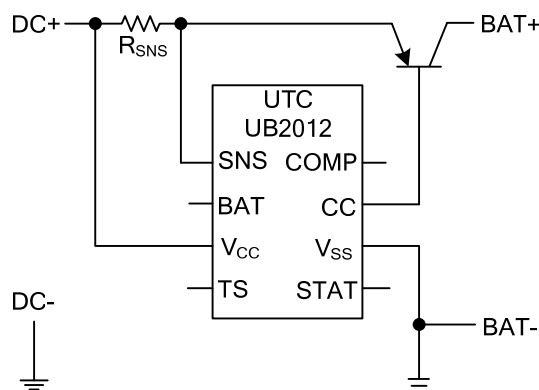

Fig. 5 Current Sensing

■ **APPLICATION INFORMATION(Cont.)**

**VOLTAGE REGULATION PHASE**

The voltage regulation feedback is through the BAT pin. This input is tied directly to the positive side of the battery pack. The UTC **UB2012** monitors the battery-pack voltage between the BAT and VSS pins. According to the voltage regulation, there are four versions of UTC **UB2012**, namely, 4.1V, 4.2V, 8.2V and 8.4V.

Other regulation voltages can be achieved by adding a voltage divider between the positive and negative terminals of the battery pack and using UTC **UB2012C** or UTC **UB2012D**. The voltage divider presents scaled battery-pack voltage to BAT input. (See Fig. 7, 8) The resistor values RB1 and RB2 for the voltage divider are calculated by the following equation:

$$\frac{R_{B1}}{R_{B2}} = (N \times \frac{V_{(CELL)}}{V_{O(REG)}}) - 1 \tag{2}$$

Where: N = Number of cells in series, V<sub>(CELL)</sub> = Desired regulation voltage per cell

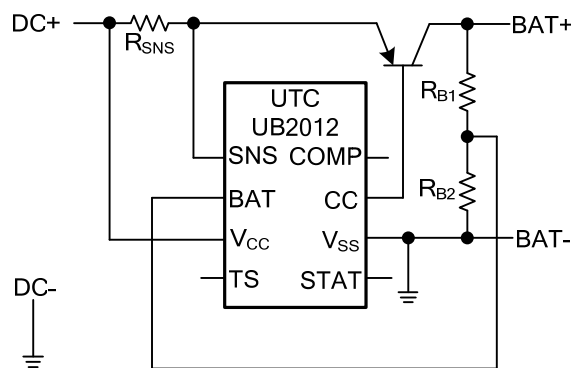

Fig. 6 Optional Voltage Divider for Nonstandard Regulation Voltage

**CHARGE TERMINATION AND RECHARGE**

The UTC **UB2012** monitors the charging current during the voltage-regulation phase. The UTC **UB2012** declares a done condition and terminates charge when the current tapers off to the charge termination threshold, I<sub>(TERM)</sub>. A new charge cycle begins when the battery voltage falls below the V<sub>(RCH)</sub> threshold.

■ APPLICATION INFORMATION(Cont.)

**BATTERY TEMPERATURE MONITORING**

The UTC **UB2012** continuously monitors temperature by measuring the voltage between the TS and VSS pins. A negative- or a positive-temperature coefficient thermistor (NTC, PTC) and an external voltage divider typically develop this voltage. (See Fig. 9) The UTC **UB2012** compares this voltage against its internal  $V_{(TS1)}$  and  $V_{(TS2)}$  thresholds to determine if charging is allowed. (See Fig. 10) The temperature sensing circuit is immune to any fluctuation in  $V_{CC}$ , since both the external voltage divider and the internal thresholds ( $V_{(TS1)}$  and  $V_{(TS2)}$ ) are referenced to  $V_{CC}$ .

The resistor values of  $R_{(T1)}$  and  $R_{(T2)}$  are calculated by the following equations:

For NTC Thermistors:

$$R_{T1} = \frac{5 \times R_{TH} \times R_{TC}}{3 \times (R_{TC} - R_{TH})} \tag{3}$$

$$R_{T2} = \frac{5 \times R_{TH} \times R_{TC}}{[(2 \times R_{TC}) - (7 \times R_{TH})]} \tag{4}$$

For PTC Thermistors:

$$R_{T1} = \frac{5 \times R_{TH} \times R_{TC}}{3 \times (R_{TH} - R_{TC})} \tag{5}$$

$$R_{T2} = \frac{5 \times R_{TH} \times R_{TC}}{[(2 \times R_{TH}) - (7 \times R_{TC})]} \tag{6}$$

Where  $R_{(TC)}$  is the cold temperature resistance and  $R_{(TH)}$  is the hot temperature resistance of thermistor, as specified by the thermistor manufacturer.

$R_{T1}$  or  $R_{T2}$  can be omitted if only one temperature (hot or cold) setting is required. Applying a voltage between the  $V_{(TS1)}$  and  $V_{(TS2)}$  thresholds to pin TS disables the temperature-sensing feature.

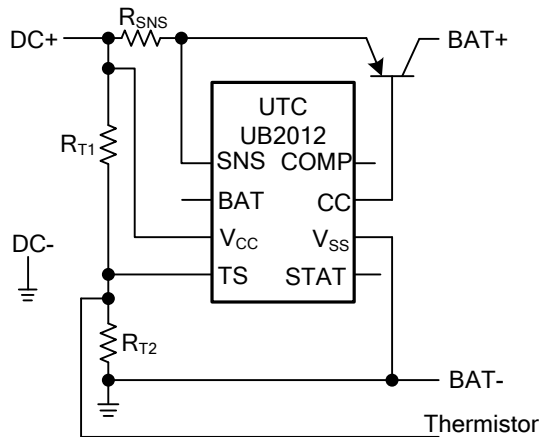

Fig. 7 Temperature Sensing Circuits

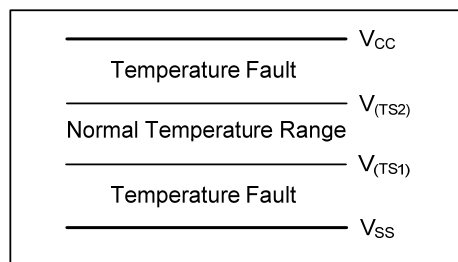

Fig. 8 UTC **UB2012** TS Input Thresholds

■ **APPLICATION INFORMATION(Cont.)**

**CHARGE INHIBIT FUNCTION**

The TS pin can be used as charge-inhibit input. The user can inhibit charge by connecting the TS pin to VCC or VSS (or any level outside the  $V_{(TS1)}$  to  $V_{(TS2)}$  thresholds). Applying a voltage between the  $V_{(TS1)}$  and  $V_{(TS2)}$  thresholds to pin TS returns the charger to normal operation.

**CHARGE STATUS INDICATION**

The UTC **UB2012** reports the status of the charger on the 3-state STAT pin. The following table summarized the operation of the STAT pin.

CONDITION	STAT PIN
Battery conditioning and charging	High
Charge complete (Done)	Low
Temperature fault or sleep mode	Hi-Z

The STAT pin can be used to drive a single LED (Figure 1), dual-chip LEDs (Fig. 4) or for interface to a host or system processor (Fig. 11). When interfacing the UTC **UB2012** to a processor, the user can use an output port, as shown in Figure 11, to recognize the high-Z state of the STAT pin. In this configuration, the user needs to read the input pin, toggle the output port and read the STAT pin again. In a high-Z condition, the input port always matches the signal level on the output port.

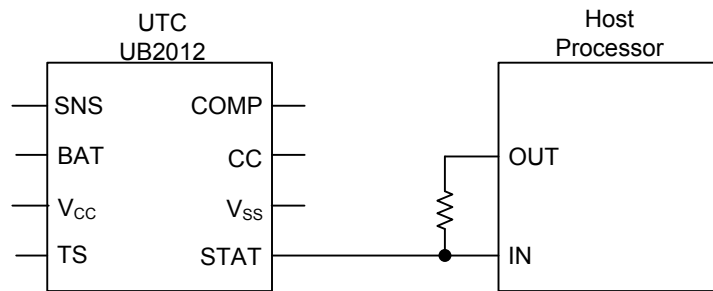

Figure 9 Interfacing the UTC **UB2012** to a Host Processor

**LOW-POWER SLEEP MODE**

The UTC **UB2012** enters the sleep mode if the  $V_{CC}$  falls below the voltage at the BAT input. This feature prevents draining the battery pack during the absence of  $V_{CC}$ .

## ■ APPLICATION INFORMATION(Cont.)

### SELECTING AN EXTERNAL PASS-TRANSISTOR

The UTC **UB2012** is designed to work with both PNP transistor and P-channel MOSFET. The device should be chosen to handle the required power dissipation, given the circuit parameters, PCB layout and heat sink configuration. The following examples illustrate the design process for either device:

#### PNP TRANSISTOR:

Selection steps for a PNP bipolar transistor: Example:  $V_I = 4.5V$ ,  $I_{(REG)} = 1A$ , 4.2-V single-cell Li-Ion (UTC **UB2012C**).  $V_I$  is the input voltage to the charger and  $I_{(REG)}$  is the desired charge current (see Fig. 1).

1. Determine the maximum power dissipation,  $P_D$ , in the transistor.

The worst case power dissipation happens when the cell voltage,  $V_{(BAT)}$ , is at its lowest (typically 3V at the beginning of current regulation phase) and  $V_I$  is at its maximum.

Where  $V_{CS}$  is the voltage drop across the current sense resistor.

$$P_D = (V_I - V_{(CS)} - V_{(BAT)}) \times I_{(REG)} \quad (7)$$

$$P_D = (4.5 - 0.1 - 3) \times 1A$$

$$P_D = 1.4W$$

2. Determine the package size needed in order to keep the junction temperature below the manufacturer's recommended value,  $T_{JMAX}$ . Calculate the total theta,  $\theta$  ( $^{\circ}C/W$ ), needed.

$$\theta_{JA} = \frac{(T_{MAX(J)} - T_A(MAX))}{P_D} \quad (8)$$

$$\theta_{JA} = \frac{(150 - 40)}{1.4}$$

$$\theta_{JA} = 78^{\circ}C/W$$

Now choose a device package with a theta at least 10% below this value to account for additional thetas other than the device. A SOT-223 package, for instance, has typically a theta of  $60^{\circ}C/W$ .

3. Select a collector-emitter voltage,  $V_{(CE)}$ , rating greater than the maximum input voltage. A 15-V device will be adequate in this example.
4. Select a device that has at least 50% higher drain current  $I_C$  rating than the desired charge current  $I_{(REG)}$ .
5. Using the following equation calculate the minimum beta ( $\beta$  or  $h_{FE}$ ) needed:

$$\beta_{MIN} = I_{C(MAX)} / I_B \quad (9)$$

$$\beta_{MIN} = 1 / 0.035$$

$$\beta_{MIN} = 28$$

Where  $I_{MAX(C)}$  is the maximum collector current (in this case same as  $I_{(REG)}$ ), and  $I_B$  is the base current (chosen to be 35 mA in this example).

Now choose a PNP transistor that is rated for  $V_{(CE)} \geq 15V$ ,  $\theta_{JA} \leq 78^{\circ}C/W$ ,  $I_C \geq 1.5A$ ,  $\beta_{MIN} \geq 28$  and that is in a SOT-223 package.

## ■ APPLICATION INFORMATION(Cont.)

### SELECTING AN EXTERNAL PASS-TRANSISTOR (Cont.)

#### P-CHANNEL MOSFET:

Selection steps for a P-channel MOSFET: Example:  $V_I = 5.5\text{ V}$ ,  $I_{(REG)} = 500\text{mA}$ , 4.2-V single-cell Li-Ion (UTC **UB2012C**).  $V_I$  is the input voltage to the charger and  $I_{(REG)}$  is the desired charge current (see Figure 4).

1. Determine the maximum power dissipation,  $P_D$ , in the transistor.

The worst case power dissipation happens when the cell voltage,  $V_{(BAT)}$ , is at its lowest (typically 3 V at the beginning of current regulation phase) and  $V_I$  is at its maximum.

Where  $V_D$  is the forward voltage drop across the reverse-blocking diode (if one is used), and  $V_{CS}$  is the voltage drop across the current sense resistor.

$$P_D = (V_I - V_D - V_{(CS)} - V_{(BAT)}) \times I_{(REG)} \quad (10)$$

$$P_D = (5.5 - 0.4 - 0.1 - 3) \times 0.5\text{A}$$

$$P_D = 1\text{W}$$

2. Determine the package size needed in order to keep the junction temperature below the manufacturer's recommended value,  $T_{JMAX}$ . Calculate the total theta,  $\theta(^{\circ}\text{C}/\text{W})$ , needed.

$$\theta_{JA} = \frac{(T_{MAX(J)} - T_{A(MAX)})}{P_D} \quad (11)$$

$$\theta_{JA} = \frac{(150 - 40)}{1}$$

$$\theta_{JA} = 110^{\circ}\text{C}/\text{W}$$

Now choose a device package with a theta at least 10% below this value to account for additional thetas other than the device. A SOP-8 package, for instance, has typically a theta of  $70^{\circ}\text{C}/\text{W}$ .

3. Select a drain-source voltage,  $V_{(DS)}$ , rating greater than the maximum input voltage. A 12V device will be adequate in this example.
4. Select a device that has at least 50% higher drain current ( $I_D$ ) rating than the desired charge current  $I_{(REG)}$ .
5. Verify that the available drive is large enough to supply the desired charge current.

$$V_{(GS)} = (V_D + V_{(CS)} + V_{OL(CC)}) - V_I \quad (12)$$

$$V_{(GS)} = (0.4 + 0.1 + 1.5) - 5.5$$

$$V_{(GS)} = -3.5$$

Where  $V_{(GS)}$  is the gate-to-source voltage,  $V_D$  is the forward voltage drop across the reverse-blocking diode (if one is used), and  $V_{CS}$  is the voltage drop across the current sense resistor, and  $V_{OL(CC)}$  is the CC pin output low voltage specification for the UTC **UB2012**.

Select a MOSFET with gate threshold voltage,  $V_{(GSTH)}$ , rating less than the calculated  $V_{(GS)}$ .

Now choose a P-channel MOSFET transistor that is rated for  $V_{DS} \leq -15\text{V}$ ,  $\theta_{JA} \leq 110^{\circ}\text{C}/\text{W}$ ,  $I_D \geq 1\text{A}$ ,  $V_{(GSTH)} \geq -3.5\text{V}$  and in a SOP package.

■ APPLICATION INFORMATION(Cont.)

**SELECTING INPUT CAPACITOR**

In most applications, a high-frequency decoupling capacitor is required. A 0.1µF ceramic, placed in proximity to VCC and VSS pins, works well. The UTC **UB2012** works with both regulated and unregulated external dc supplies. If a non-regulated supply is chosen, the supply unit should have enough capacitance to hold up the supply voltage to the minimum required input voltage at maximum load, otherwise more capacitance must be added to the input of the charger.

**SELECTING OUTPUT CAPACITOR**

For loop stability, the UTC **UB2012** does not require any output capacitor. However, when a battery is not present, the user can add output capacitance in order to control the output voltage. The charger quickly charges the output capacitor to the regulation voltage, but the output voltage decays slowly, because of the low leakage current on the BAT pin, down to the recharge threshold. Addition of a 0.1µF ceramic capacitor, for instance, results in a 100 mV (pp) ripple waveform, with an approximate frequency of 25Hz. Higher capacitor values can be used if a lower frequency is desired.

**AUTOMATIC CHARGE-RATE COMPENSATION**

In order to compensate safely for internal impedance of the battery pack, the UTC **UB2012** uses the automatic charge-rate compensation technique to reduce charging time. The automatic charge-rate compensation feature is disabled by connecting the COMP pin to VCC in current-sensing configuration.

Fig. 12 outlines the main components of a single-cell Li-Ion battery pack. The Li-Ion battery pack consists of a cell, protection circuit, fuse, current sense-resistors, connector, and some wiring. There are some resistances in each of these components. Total impedance of the battery pack is equal to the sum of the minimum resistances of all battery-pack components. Using the minimum resistance values reduces the odds for overcompensating. Overcompensating may activate the safety circuit of the battery pack.

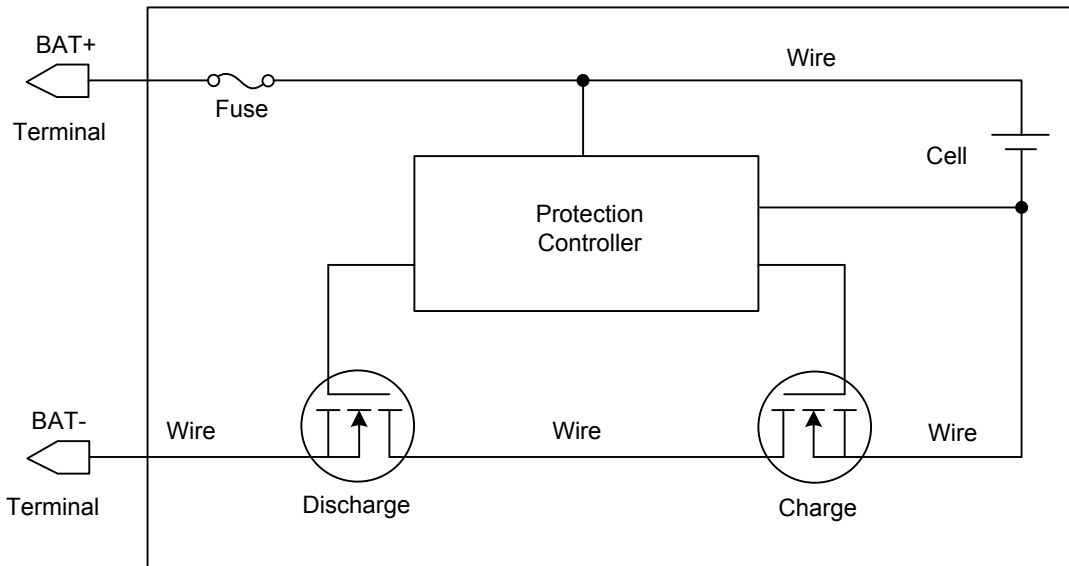

Fig. 10 Typical Components of a Single-Cell Li-Ion Pack

Compensation is achieved through input pin COMP (Fig. 13). A portion of the current-sense voltage, presented through this pin, is scaled by a factor of  $G_{(COMP)}$  and summed with the regulation threshold,  $V_{O(REG)}$ . This process increases the output voltage to compensate for the battery pack's internal impedance and for undesired voltage drops in the circuit.

■ APPLICATION INFORMATION(Cont.)

Automatic charge-rate compensation setup requires the following information:

- \* Total impedance of battery pack ( $Z_{(PACK)}$ )
- \* Maximum charging current ( $I_{(REG)}$ )

The voltage drop across the internal impedance of battery pack,  $V_{(Z)}$ , can then be calculated using the following equation:

$$V_{(Z)} = Z_{(PACK)} \times I_{(REG)} \tag{13}$$

The required compensation is then calculated using the following equations:

$$V_{(COMP)} = \frac{V_{(Z)}}{G_{(COMP)}} \tag{14}$$

$$V_{(PACK)} = V_{O(REG)} + (G_{(COMP)} \times V_{(COMP)})$$

Where  $V_{(COMP)}$  is the voltage on COMP pin. This voltage is referenced to VCC in current sensing configuration.  $V_{(PACK)}$  is the voltage across the battery pack.

The values of  $R_{(COMP1)}$  and  $R_{(COMP2)}$  can be calculated using the following equation:

$$\frac{V_{(COMP)}}{V_{(SNS)}} = \frac{R_{COMP2}}{R_{COMP1} + R_{COMP2}} \tag{15}$$

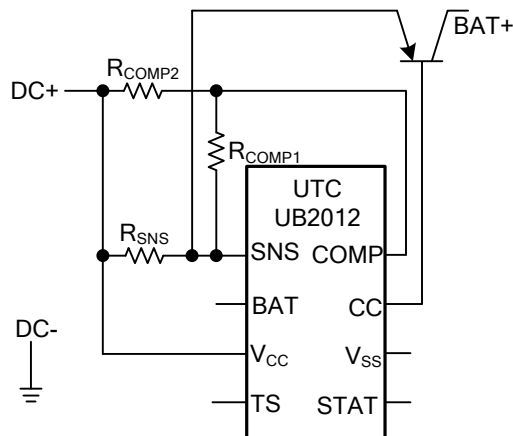

Fig. 11 Automatic Charge-Rate Compensation Circuits

### ■ APPLICATION INFORMATION(Cont.)

The following example illustrates these calculations:

Assume  $Z_{(PACK)} = 100 \text{ m}\Omega$  ,  $I_{(REG)} = 500 \text{ mA}$ , current sensing UTC **UB2012B**

$$V_{(Z)} = Z_{(PACK)} \times I_{(REG)} \quad (16)$$

$$V_{(Z)} = 0.1 \times 0.5$$

$$V_{(Z)} = 50 \text{ mV}$$

$$V_{(COMP)} = \frac{V_{(Z)}}{G_{(COMP)}} \quad (17)$$

$$V_{(COMP)} = 0.05 / 2.2$$

$$V_{(COMP)} = 22.7 \text{ mV}$$

Let  $R_{COMP2} = 10 \text{ k}\Omega$

$$R_{COMP1} = \frac{R_{COMP2} \times (V_{(SNS)} - V_{(COMP)})}{V_{(COMP)}} \quad (18)$$

$$R_{COMP1} = 10 \text{ k} \times \frac{(105 \text{ mV} - 22.7 \text{ mV})}{22.7 \text{ mV}}$$

$$R_{COMP1} = 36.25 \text{ k}\Omega$$

Use the closest standard value (36.0 k $\Omega$ ) for  $R_{COMP1}$

UTC assumes no responsibility for equipment failures that result from using products at values that exceed, even momentarily, rated values (such as maximum ratings, operating condition ranges, or other parameters) listed in products specifications of any and all UTC products described or contained herein. UTC products are not designed for use in life support appliances, devices or systems where malfunction of these products can be reasonably expected to result in personal injury. Reproduction in whole or in part is prohibited without the prior written consent of the copyright owner. The information presented in this document does not form part of any quotation or contract, is believed to be accurate and reliable and may be changed without notice.