



UA7524

LINEAR INTEGRATED CIRCUIT

POWER FACTOR CONTROLLER

DESCRIPTION

The UTC **UA7524** provides the necessary features to implement the Electronic BALLAST control and S.M.P.S application for designing active power factor correction circuit

FEATURES

- * Internal self-starting
- * Micro power start up mode
- * Included under voltage lockout circuit
- * Internal 2% reference
- * High output current: peak 500mA

ORDERING INFORMATION

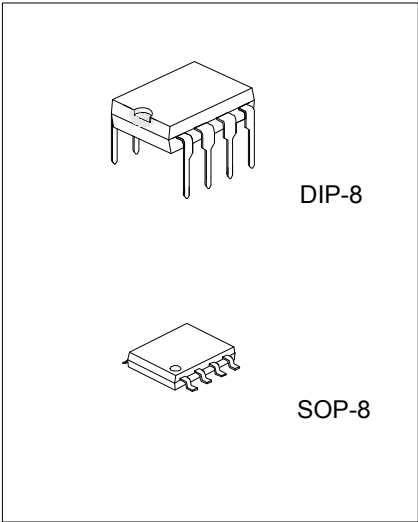

Ordering Number		Package	Packing
Lead Free	Halogen Free		
UA7524L-D08-T	UA7524G-D08-T	DIP-8	Tube
UA7524L-S08-R	UA7524G-S08-R	SOP-8	Tape Reel
UA7524L-S08-T	UA7524G-S08-T	SOP-8	Tube

<p>UA7524L-D08-T</p> <p>(1) Packing Type (2) Package Type (3) Lead Free</p>	<p>(1) T: Tube, R: Tape Reel (2) D08: DIP-8, S08: SOP-8 (3) G: Halogen Free, L: Lead Free</p>
---	---

■ BLOCK DIAGRAM

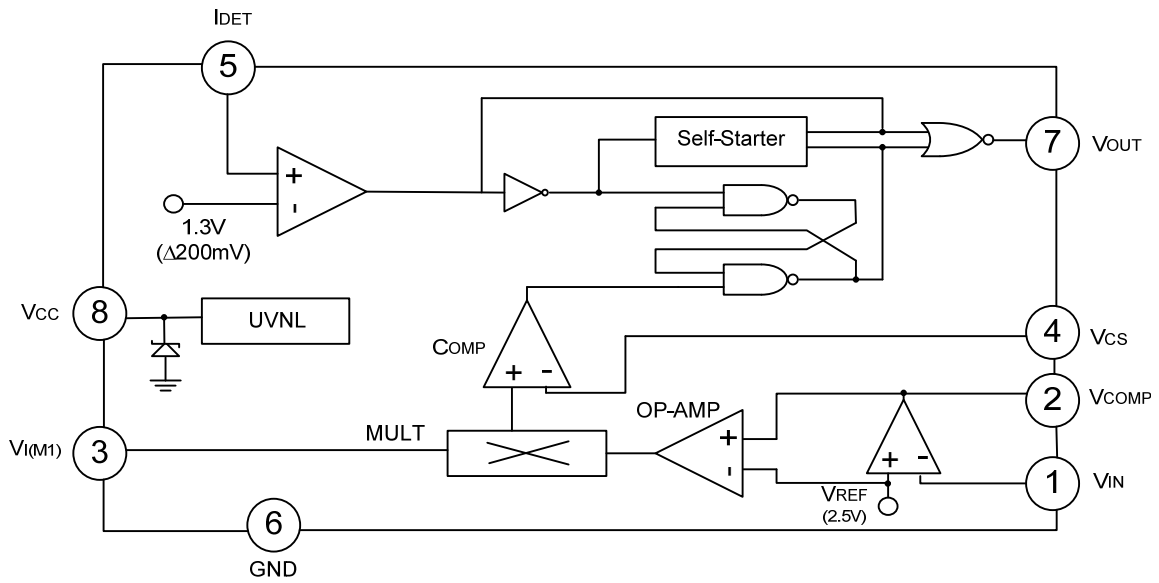

■ ABSOLUTE MAXIMUM RATINGS (T_A = 25°C)

PARAMETER	SYMBOL	RATINGS	UNIT
Supply Voltage	V _{CC}	20	V
Peak Driver Output Current	I _{O(PEAK)}	500	mA
Detect Clamping Diode Current	I _{DET}	10	mA
Output Clamping Diode Current	I _{O(CD)}	10	mA
Junction Temperature	T _J	+125	°C
Operating Temperature	T _{OPR}	-20~+85	°C
Storage Temperature	T _{STG}	-40~+150	°C

Note 1. Absolute maximum ratings are those values beyond which the device could be permanently damaged.

Absolute maximum ratings are stress ratings only and functional device operation is not implied.

2. The device is guaranteed to meet performance specification within 0°C~+70°C operating temperature range and assured by design from -20°C~+85°C.

■ ELECTRICAL CHARACTERISTICS (T_A = 25°C, All voltage referenced to GND, unless otherwise specified)

PARAMETER	SYMBOL	TEST CONDITIONS	MIN	TYP	MAX	UNIT
Under Voltage Lockout Section						
Start Threshold Voltage	V _{THR(ST)}		9.2	10	10.8	V
UV lockout Hysteresis	V _{HYS(UV)}		1.8	2.0	2.2	V
Supply Zener Voltage	V _Z			17		V
SUPPLY CURRENT SECTION						
Start-up Supply Current	I _{START}	V _{CC} <V _{I(THR)}		0.25	0.5	mA
Operating Supply Current	I _{CC}	V _{CC} =12V, No load		6	12	mA
Dynamic Operating Current	I _{CC(D)}	V _{CC} =12V, f=50KHZ, C _{GS} =1000pF		10	20	mA
REFERENCE SECTION (Note 1)						
Reference Voltage	V _{REF}		2.45	2.5	2.55	V
Line Regulation	ΔV _{OUT}	12V< V _{CC} <16V		0.1	10	mV
Load Regulation	ΔV _{OUT}	0< I _{REF} <2mA		0.1	10	mV
Temperature Stability	ST _T			20		mV
ERROR AMPLIFIER SECTION						
Input Offset Voltage	V _{I(OFF)}		-15		15	mV
Input Bias Current	I _{I(BIAS)}		-1	-0.1	1	μA
Large Signal Open Loop gain	G _V		60	100		dB
Power Supply Rejection Ratio	RR		60	86		dB
Output Current	I _{SOURCE}		2			mA
	I _{SINK}				-2	mA
Output Voltage range	V _{O(P)}		1.2		4	V
Unity Gain Bandwidth	UB _W			1.0		MHZ
Phase Margin	MPH			57		°C
MULTIPLIER SECTION						
M1 Input Voltage Range	V _{I(M1)}		0		2	V
M2 Input Voltage Range	V _{I(M2)}		V _{REF}		V _{REF} +1	V
Input Bias Current	I _{I(BIAS)}		-2	-0.5	2	μA
Multiplier Gain (Note2)	G _V	V _{I(M1)} =0.5V, V _{I(M2)} =3V		0.8		/V
Multiplier Gain Stability	ST _T			-0.2		%/°C
CURRENT DETECT SECTION						
Input Voltage Threshold	V _{I(THR)}		1.0	1.3	1.6	V
Hysteresis	V _{HYS}			200		mV

■ ELECTRICAL CHARACTERISTICS(Cont.)

PARAMETER	SYMBOL	TEST CONDITIONS	MIN	TYP	MAX	UNIT
Input Low Clamp Voltage	$V_{IC(L)}$	$I_{DET}=0mA$			0.95	V
Input High Clamp Voltage	$V_{IC(H)}$	$I_{DET}=3mA$	6.1	7.1		V
Input Current	I_{IN}	$0.8V < V_{DET} < 6V$		5		μA
Input Clamp Diode Current	$I_{I(CD)}$	$V_{DET} < 0.9V, V_{DET} > 6V$			3	mA
OUTPUT SECTION						
Output Voltage(High)	$V_{O(H)}$	$I_{OUT} = -10mA, V_{CC} = 12V$	7	9		V
Output Voltage(Low)	$V_{O(L)}$	$I_{OUT} = 10mA, V_{CC} = 12V$		0.8	1.8	V
Rising Time	t_R	$C_L = 1000pF$		100	200	ns
Falling Time	t_F	$C_L = 1000pF$		90	200	ns
SELF-START SECTION						
Self Starting Time	t_{SS}		12			μs

Note: 1. Reference can not be tested on the PKG

2. $G_V = V_{O(M)} / (V_{I(M1)} * (V_{I(M2)} - V_{REF}))$

APPLICATION CIRCUIT

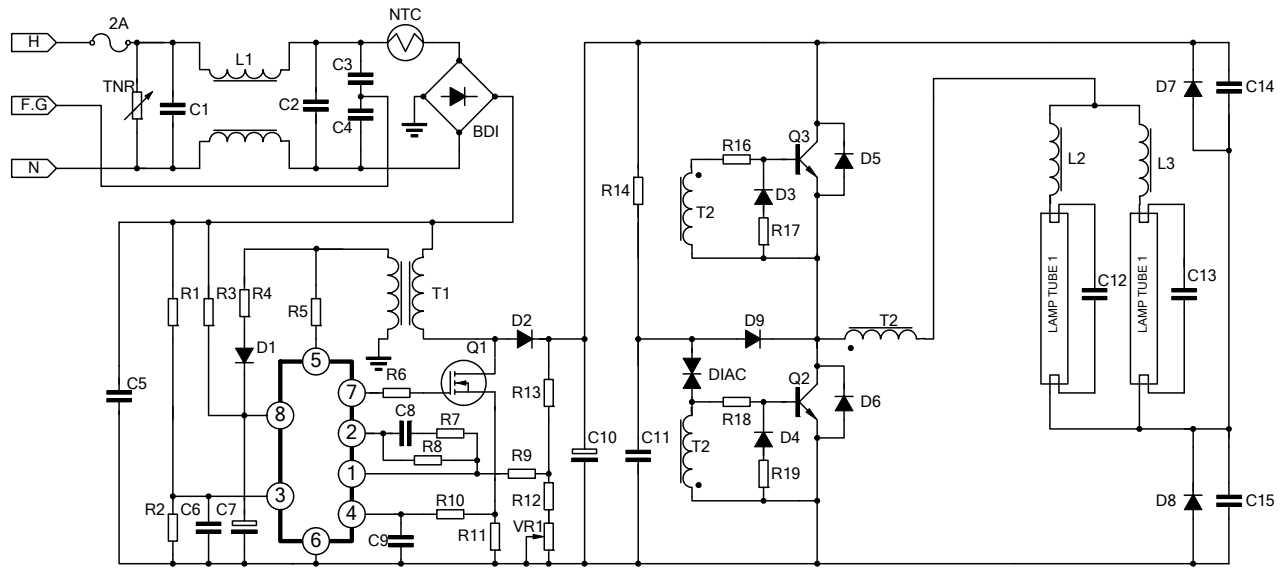

PART LIST

RESISTOR		CAPACITOR		SEMICONDUCTOR		MAGNETICS	
R1	1.8M	C1	0.1μF	IC1	UTC UA7524	T1	E1-25(PC30):P=70T,S=4T,Gap=0.5mm
R2	10K	C2	0.1μF	Q1	IRF830	T2	D15(GP-5):P=3T,S=13T
R3	100K	C3	4700pF	Q2	2SC5039	L1	EE-25(Iron Power),80mH
R4	3.3Ω	C4	4700pF	Q3	2SC5039	L2	E1-25(PC30):150T,Gap=0.4mm
R5	22K	C5	0.1μF	D1	1N4004		
R7	2.2K	C6	0.01μF	D2	1N4937		
R8	2.2M	C7	100μF	D3	1N4148		
R9	150K	C8	0.1μF	D4	1N4148		
R10	330Ω	C9	3300pF	D5	FR107		
R11	0.75Ω	C10	47μF/450V	D6	FR107		
R12	5.1K	C11	0.1μF	D7	FR107		
R13	1M	C12	3300pF	D8	FR107		
R14	390K	C13	3300pF	BD1	PBP204		
R15	3.9M	C14	0.01μF	TNR	12G471		
R16	5.1Ω	C15	0.01μF	DIAIC	32V		
R17	27Ω						
R18	5.1Ω						
R19	27Ω						
VR1	5K						
NTC	10Ω						

UTC assumes no responsibility for equipment failures that result from using products at values that exceed, even momentarily, rated values (such as maximum ratings, operating condition ranges, or other parameters) listed in products specifications of any and all UTC products described or contained herein. UTC products are not designed for use in life support appliances, devices or systems where malfunction of these products can be reasonably expected to result in personal injury. Reproduction in whole or in part is prohibited without the prior written consent of the copyright owner. The information presented in this document does not form part of any quotation or contract, is believed to be accurate and reliable and may be changed without notice.